



1-800-426-5464

# Hoffer Mini-Flowmeter Engineering Guide

## MF SERIES FOR LOW FLOW APPLICATIONS

New devices with low flow measurement capability are increasingly in demand by industrial and laboratory users as requirements for accurate low flow measurement devices proliferate.

The Hoffer MF Series has been developed to meet the need for a low flow measurement device for service on clean, low and moderate viscosity liquids, and for gas measurement applications.

The MF Series is a family of low flow rate measurement devices based on a pelton wheel like rotor. The measured fluid is directed tangentially thru a velocity nozzle against the pelton rotor causing it to rotate. The motion of the rotor is sensed by the pickup coil and converted to a pulsing output signal where the frequency is related to the flow rate, and the accumulated pulses are related to the total volume passing thru the flowmeter.

### Materials Selection and Construction

Selection of the materials of construction is usually dictated by the requirements of performance, durability, media compatibility, availability, and cost considerations.

The materials of construction for the MF Series are intended to provide a standard flowmeter configuration which will suit the requirements of a broad base of industrial users. Our applications group can assist you in the selection of options that will provide the construction which offers the optimum combination of useful

range, corrosion resistance and operating life for a particular application.

### Bearing Selection

Bearings are chosen based on media compatibility, desired turndown range, service life, serviceability, cost, and accuracy considerations. Several bearing types are available including self-lubricating, ceramic hybrid ball bearings and sleeve constructions in tungsten carbide and carbon composites.

The side access port permits for rapid inspection and servicing of the flowmeter internals including the bearings.

When selecting among several chemically compatible bearings, the ball bearing design offers the highest accuracy and widest usable range and may be considered the standard. It is required for gas measurement applications. Field bearing replacement may be performed without a significant shift in the original calibration.



Tungsten carbide offers the most durable bearing material in service conditions where it is compatible, and will offer the longest life in rugged industrial liquid service.

Hard carbon composite bearings offer properties which are nearly chemically inert to many corrosive fluids and are utilized for this reason in demanding applications.

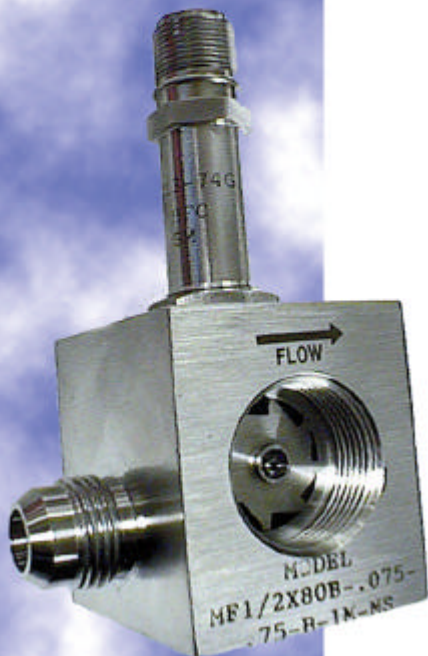

## Flowmeter Pickup Selection

The flowmeter pickup coil senses the motion of the rotor and converts it to a pulsing electrical signal which is of a discrete digital nature. Two basic pickup types are offered for use with the MF Series which will satisfy standard electrical interface requirements for turbine flowmeters.

The standard flowmeter pickup is a low drag magnetic type whose self-generating output signal voltage is approximately sinusoidal. The amplitude of the output signal is a function of flow rate, with a minimum signal strength which is greater than 30 mVp-p. The standard maximum frequency ranges at the flowmeter's full scale capacity are offered at 1000, 2000, and 3000 Hz. This signal may be transmitted up to 200 feet without preamplification and is directly compatible with many instruments. A flow range of 10:1 is common with this pickup type on liquid applications.

The Redi-Pulse pickup coil, offered in a magnetic type for the MF Series, includes a self-contained preamplifier within the pickup coil housing. The pickup coil produces a

conditioned pulse output without the need of a separate signal conditioner and may be transmitted up to 5,000 feet. Since the flowmeter signal is conditioned directly at the flowmeter, this feature offers the benefit of greater noise immunity when transmitting through a noisy environment. When size or weight is an issue, the Redi-Pulse eliminates the need for conventional signal conditioners that are meter mounted in a junction box directly on top of the flowmeter. Redi-Pulse coils are certified with the CE mark for compliance with EMC Directive 89/336/EEC. See Redi-Pulse technical data sheet for more information and detailed specifications on this coil.

## Performance Characteristics

The basic performance characteristics of the Mini-Flowmeter are depicted in Figures 1 and 2. The MF Series establishes a linear response after an initial offset correction when operated at a constant viscosity.

Over the linear flow range, the input/output characteristic takes the following form:

Equation 1

$$\text{Frequency} = C1 \times \text{Flow rate} - C2$$

The Mini-Flowmeter requires the use of a linearization conditioner available in all Hoffer flow measurement instrumentation. Accuracies of  $\pm 1\%$  of reading typical after initial correction for offset. Better accuracies approaching  $\pm 0.2\%$  are possible using flow computers which can store the entire characteristics of the Mini-Flowmeter.

The K-Factor is the number of pulses per unit volume produced by the flowmeter under a given set of conditions. Repeatability is a measure of the stability of the output under a given set of flowing conditions. The repeatability is defined as the allowable percentage deviation from the stated K-factor. Other performance characteristics include the pressure drop characteristic and output frequency range and are addressed in later sections.

## ELECTRONIC LINEARIZATION ACCESSORIES FOR THE MF SERIES

Several methods are available to reduce the inherent nonlinearity of the MF Series flowmeter. The most economical method of linearization is by offset frequency injection. In this method, a signal equal to the offset frequency of the Mini-Flowmeter is injected electronically to the actual output of the flowmeter. The result effectively shifts the output characteristic to that of the ideal. A number of low cost linearizers are available for Hoffer Signal Conditioners/Converters and Indicator Instrument Series.

Factory calibrations normally provide the user with a precalibrated Mini-Flowmeter and Converter calibrated to the users specifications.

## Hazardous and Weatherproof Coil Enclosures

The explosion-proof requirements of UL Class I, Div 1 are implemented by enclosing the pickup coil in a suitably rated housing. Signal Conditioner/Converters may also be mounted within this enclosure. Addition of an "O" Ring provides an additional NEMA-4 rating. Intrinsically safe meter systems are also available.

## Installation Requirements

The MF Series is capable of sensing fluid flow in one direction only. The flowmeter may be installed with the pickup coil in either a vertical or horizontal position.

Filtration to at least 100 microns is recommended to prolong the life of the flowmeter and prevent damage to the bearings.

Flow pulsation should be minimized through the application of pulsation dampeners before the flowmeter.

Figure 1

### MINI-FLOWMETER OUTPUT CHARACTERISTIC

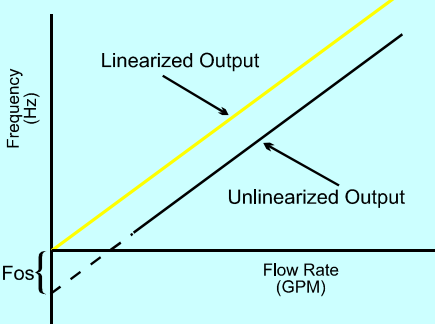

Figure 2

### NORMALIZED MINI-FLOWMETER CALIBRATION CURVE

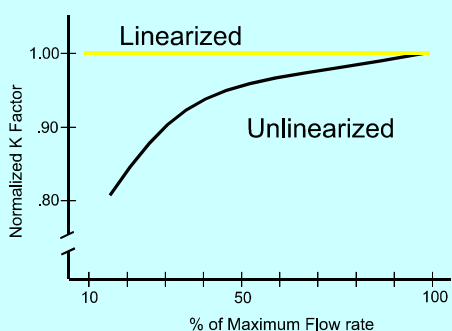
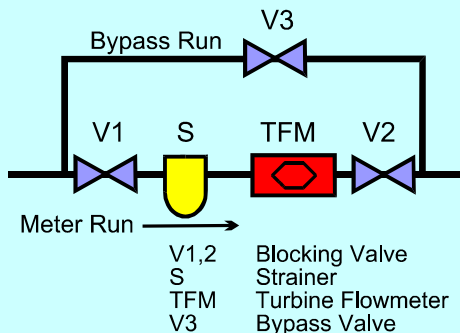

Figure 3

### TYPICAL FLOWMETER INSTALLATION



## Standard Specifications

**End Fitting Type:** 1/2" MS-33656-8 (Std. others available upon request)

**Physical:**

Operating Pressure:

1000 PSI (standard)

6000 PSI (optional)

Operating Temperature:

Mag. Pickup: -450 to +450° F

High Temp. Pickup: -450 to +850° F

**Materials:**

Housing: 316 Stainless Steel

Bearing: Ceramic Hybrid Ball Bearings

(self-lubricating)

Tungsten Carbide Sleeve

(optional)\*

Carbon Composite Sleeve

(optional)\*

Rotor: 17.4 PH (standard)

430 Stainless Steel (optional)

Ni 200 (optional)

Seal: Rulon-J (standard, others available)

## MF SERIES FOR LIQUID APPLICATIONS

The liquid MF Series offers measurement capability from .007 to 3.5 GPM in twelve overlapping ranges for service on clean, low viscosity liquids.

Size selection may be accomplished by referring to Figure 4 after giving consideration to the service, construction, and the maximum allowable pressure drop.

Fluid viscosity effects should be considered when the liquid's temperature will be varying significantly in actual service.

Adequate back pressure on the flowmeter should also be maintained to avoid cavitation which may result in metering errors.

It should be observed that with the standard magnetic pickup, no preamplifier is required in many flow indicator applications and can transmit up to 200 feet. The Redi-pulse mag pickups are available and can transmit up to 5000 feet.

## Selection Considerations

The standard liquid MF Series flowmeter consists of the basic device equipped with a magnetic pickup and self-lubricating ball bearings. The flow rate capability of this configuration is detailed in the size selection chart. This configuration was designed for serviceability. The ball bearings may be replaced in the

**Figure 4**

## Flow Rate Capability with Ball Bearings

Flow-meter Size	Linear Range				Repeatable		Repeatable	
	MIN		MAX		MIN		MAX	
	GPM	CC/M	GPM	CC/M	GPM	CC/M	GPM	CC/M
MF20	.015	57	.049	185	.007	26.5	.065	250
MF30	.017	65	.120	450	.0085	32.0	.150	575
MF40	.020	75	.150	575	.010	38.0	.200	750
MF50	.023	85	.200	750	.013	50.0	.350	1325
MF60	.025	95	.250	950	.015	57.0	.500	1900
MF70	.050	190	.500	1900	.030	115	.750	2850
MF80	.075	285	.750	2850	.040	150	1.00	3750
MF90	.085	325	.850	3200	.050	200	1.25	4750
MF100	.100	375	1.00	3750	.060	225	1.60	6000
MF125	.130	490	1.30	4900	.075	275	2.10	8000
MF150	.200	750	2.00	7500	.080	300	3.00	11500
MF175	.300	1150	3.00	11500	.100	375	3.50	13250

\* When tungsten carbide or carbon composite sleeve bearings are specified, only the linear ranges are available as the minimum flow rate is affected due to bearing drag. The MF20 and MF30 are not available with sleeve bearings.

**Figure 5**

## Gross Pressure Drop Characteristic on Water for the MF Series on Liquid Service

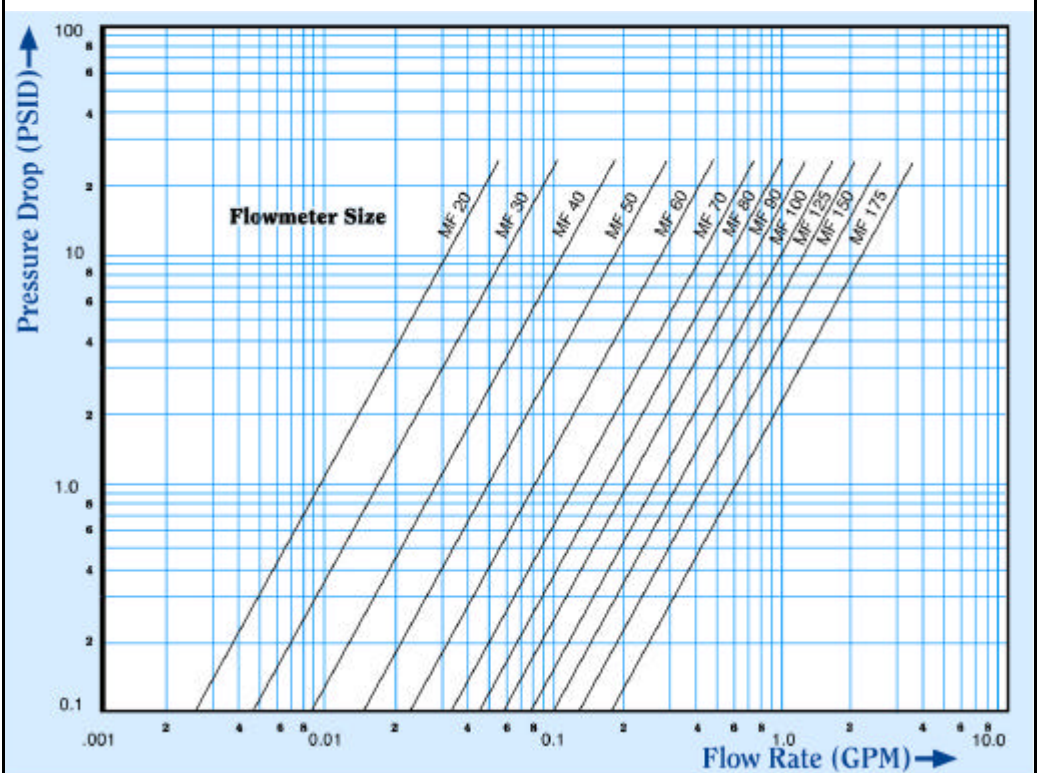

field with no special tools or repair skills.

The widest flow turndown range and best performance on viscous service is achieved with a ball bearing design. The sizing chart lists the usable range for this construction. The linear range listed is that range over which the flowmeter frequency characteristic will maintain the  $\pm 1\%$  linearity limits to a straight line at a constant viscosity after offset

correction.

Sleeve bearing designs are available for the MF 40 to 175 sizes. The ruggedness of the tungsten carbide configurations makes it attractive for industrial applications requiring long life. Carbon composite bearing designs may be used in corrosive applications. Such designs will offer greater operating life if sized to operate toward the bottom of the flowmeter range.

The pressure drop characteristics are given based on water at a viscosity of 1 Cpse and a specific gravity of 1.0. For other fluids, the following equation may be used to estimate the pressure drop across the Mini-Flowmeter given the pressure drop on water at the maximum flow rate and the fluids viscosity and density.

Equation 2

$$PSID = (Cpse)^{1/4} \times (SpGr)^{3/4} \times PSID(H_2O)$$

where:

Cpse is viscosity in centipoise

SpGr is the specific gravity

PSID(H<sub>2</sub>O) is pressure drop from Figure 5

### Specifications for Liquid Applications

**Output Frequency Range:** 50 to 1000 Hz (3333 Hz Maximum)

**Linearity:** ±1.0% reading (over 10:1 range)

**Linear Range:** 10:1 turndown with magnetic pickups and ball bearings

**Usable Flow Range:** 25:1 with ball bearings

**Repeatability:** ±0.1% typ. (±0.25% worst case)

**Reference conditions:** 1 cstk. test fluid at 70° F

### Viscosity Effects

An ideal flowmeter may be defined as one in which the output is solely a function of the fluid flow being measured. Real flowmeters display dependencies on secondary fluid properties, such as viscosity, temperature, and/or pressure. These effects tend to obscure or degrade the precision of the flow measurement.

In selecting a MF Series flowmeter for operation on a viscous fluid, it is generally preferable to size the flowmeter so it will be operated in the higher portion of its range to minimize viscosity effects in the measurement. Some loss in flow turndown range may be expected.

### MF SERIES FOR GAS APPLICATIONS

MF Series meters may be used for gas flow measurement and come in 6 overlapping sizes detailed in Figure 7. Specific criteria must be met when using the MF Series on gas flow applications. Those criteria include constant gas pressure and constant gas temperature. There is no effective method for compensating the output of the MF Series due to changing pressure and temperature. Additionally, MF Series meters must be air or gas calibrated in order to produce accurate results. Consult the factory for specific sizing and calibration recommendations.

### Special Configurations

The physical configurations for the MF Series is intended to suit the diverse requirements of the industrial users. Requests for other configurations, intended to satisfy special requirements, may be directed to the applications group at Hoffer for review and recommendations.

### Installation and Adapter Kits

Installation kits serve a two fold purpose, the first of which is to ease customer installation. The second is to facilitate adapting from the MS 33656-8 fitting on the flowmeter to the desired user end fitting. Flow straighteners are not required.

The kit consists of two lengths of 1/2" stainless steel tubing with one end flared and the length cut to an appropriate size. The mating sleeves and nuts are also provided.

The kits may be conveniently butt welded into the user's piping. Alternately, the kits may be provided with NPT or flanged connections to facilitate installation into existing lines.

### Strainers/Filters

Installation of a suitable strainer / filter reduces or eliminates the potential of bearing damage by a foreign body. Such devices also maximize the life of the flowmeter since bearing life is maximized when contaminating particles are removed prior to passage through the flowmeter. The suggested filtration recommendation is 100 microns or better.

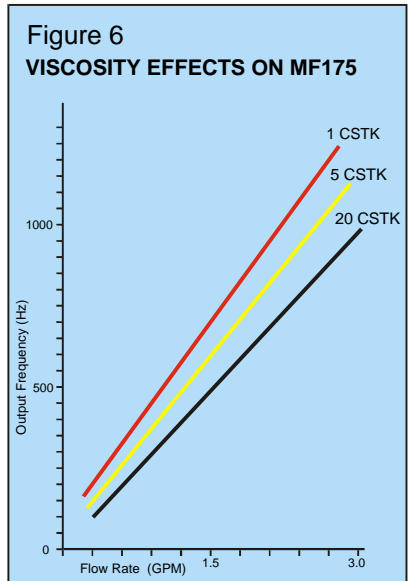

Figure 7

### Mini-Flow Gas Meter Capacity

Flowmeter Size	Maximum Flow Rate
	ACFM
MF30	0.05
MF50	0.10
MF80	0.20
MF90	0.30
MF125	0.50
MF175	1.00

# HOFFER FLOW CONTROLS, INC.

The Turbine Flowmeter Company

107 Kitty Hawk Lane, P.O. Box 2145, Elizabeth City, NC 27906-2145  
 800-628-4584 252-331-1997 FAX 252-331-2886  
 www.hofferflow.com email: info@hofferflow.com

The specifications contained herein are subject to change without notice and any user of said specifications should verify from the manufacturer that the specifications are currently in effect. Otherwise, the manufacturer assumes no responsibility for the use of specifications which may have been changed and are no longer in effect.



ISO 9001  
Registered Company

The quality system covering the design, manufacture and testing of our products is certified to International Standard ISO 9001.