

**TECHNICAL DATA SHEET**

**Replacement Parts and Calibrated Internals**

Hoffer turbine flowmeters are easily repaired in the field with a minimum number of tools. A spare complete set of calibrated internals can provide nearly continuous operation of a flowmeter that has been damaged or needs to be recalibrated, and are available in all sizes. Calibrated kits are supplied with a NIST traceable calibration data sheet. For detailed technical information, refer to the "Hoffer Engineering Guide". When ordering replacement or spare parts, please provide the Hoffer model number or serial number of the original unit.

**Component Exploded View**

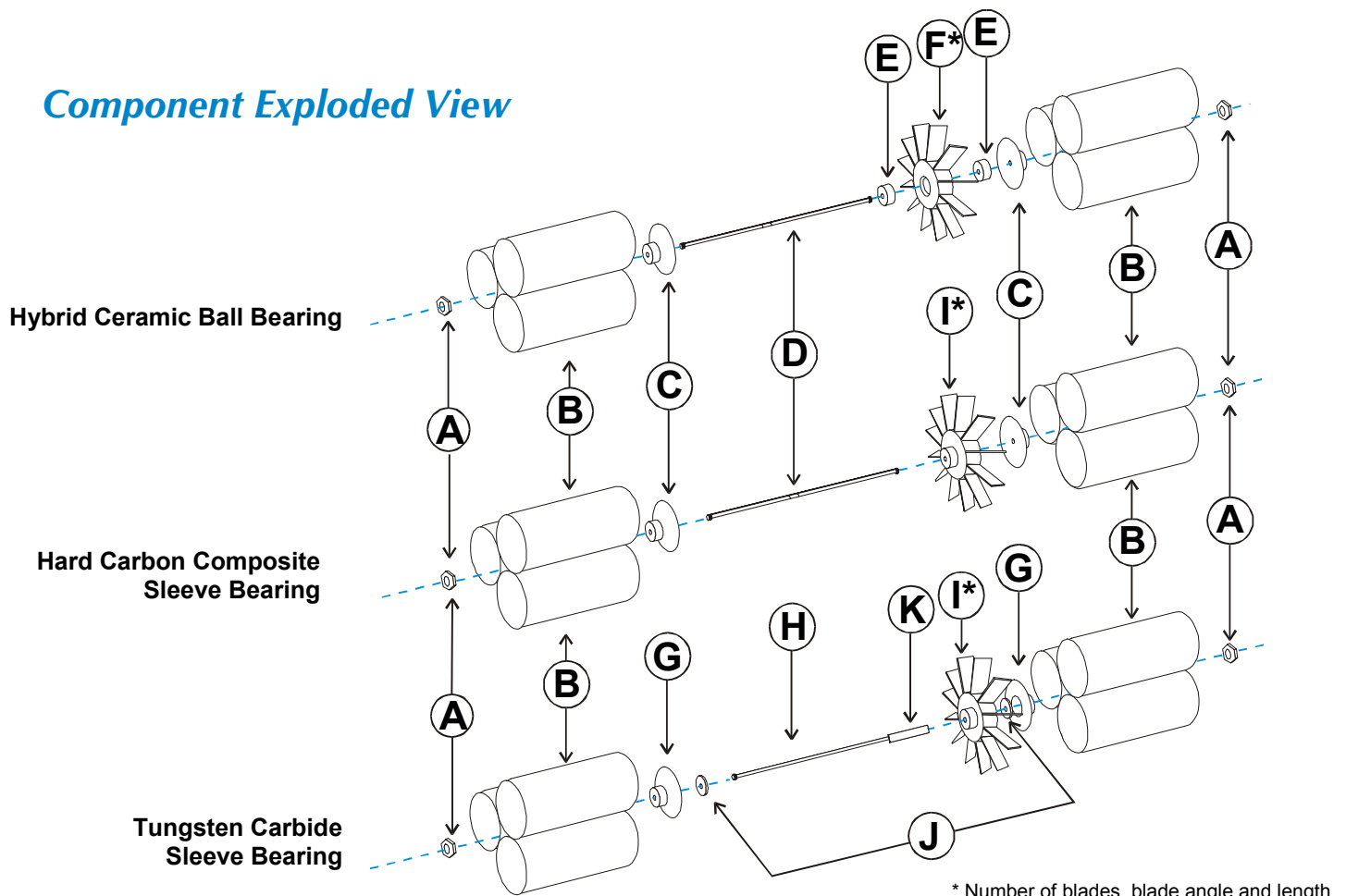

\* Number of blades, blade angle and length of blades vary with application and meter size.

**KEY**

- |                               |  |
|-------------------------------|--|
| A—Lock Nut                    | G—Cone                                   |
| B—Flow Straightener (hangers) | H—Shaft                                  |
| C—Cone                        | I—Bushing & Rotor (Press Fit at Factory) |
| D—Shaft                       | J—T/C Washers                            |
| E—Bearings                    | K—Journal                                |
| F—Rotor                       |  |

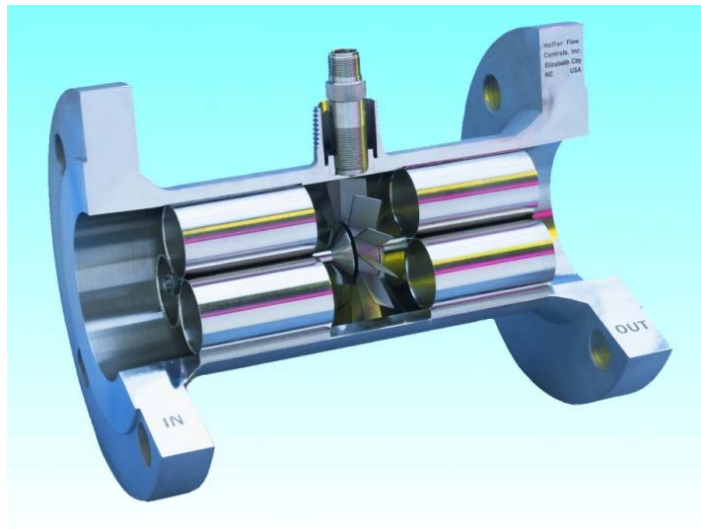

## HO Series Calibrated Spare or Replacement Internal Kits

**MODEL HO** - - - - - **INTERNALS**

Flowmeter Size \_\_\_\_\_

Minimum Flow Range \_\_\_\_\_

Maximum Flow Range \_\_\_\_\_

Bearing Type \_\_\_\_\_

**CB** -Ceramic Hybrid self-lubricating ball bearings.  
**T** -Tungsten Carbide.  
**TFE** -Teflon.  
**C** -Hard Carbon Composite.

**Note :** Calibrated kits are supplied with calibration data sheet.

## Spare and Replacement Pickup Coils

Part No.	Description or Service	Temperature Rating
MC3PAE	RF Coil 1/2" MNPT & 3" Leads	-325° to +325°F
MC3PA	RF Coil All HO Series	-325° to +325°F
PC13-110G	Cryogenic HO 1 & Up	-450° to +450°F
PC13-74G	WECO HO 2x2 & HO 3x3 Liquid & Navy	-450° to +450°F
PC13-74S	HO Series HO1 & UP & Mini-Flows	-450° to +450°F
PC24-45G	HO1/4 thru HO3/4 Cryogenic, Trident & SY100	-450° to +450°F
PC24-45S	HO1/4 thru HO 3/4 & HO1 & Larger Gas	-450° to +450°F
PC24-45EX	HO1/4 thru HO 3/4 & HO1 & Larger Gas with 1/2" MNPT & 3" Leads	-450° to +450°F
PC28-13G	High Temp High Drag	-450° to +850°F
PC3-24G	Reluctance Center Mag for All Teflon	+35° to +120°F
PC24-92G	Hydrogen Vacuum Jacket	-450° to +450°F
PC28-14G	High Temp Low Drag	-450° to +850°F
PC3-24EX	Reluctance Teflon Series with 1/2" MNPT & 3" Leads	+35° to +120°F
MC2PAHT	High Temp RF with 3' Leads	-450° to +450°F

Part No.	Description or Service	Temperature Rating
MC2PA	High Temp 2 Pin RF	-150° to +330°F
PC13-108G	Cryogenic 1" & Larger	-450° to +450°F
PC24-113G	WECO HO2x1 & HO2x1½ Liquid and Gas	-450° to +450°F
PC13-74EX	Hi Drag with 1/2" MNPT & 3" Leads	-450° to +450°F
PC13-74S	Cryogenic 1" & Larger	-450° to +450°F
RF-4	WECO's All Sizes Requiring RF	-325° to +325°F
ISM-001	Intrinsic Mag Hi Drag 1" & Up & Mini-Flow Use	-97° to +207°F
PC24-123G	WECO HO2x2 & HO3x3 Gas	-450° to +450°F
ISM-003	Intrinsic Mag Low Drag 3/4" & Smaller Use	-97° to +207°F
ISM-006	Intrinsic Reluctance for All Teflon Use	+35° to +120°F
PC28-38G	Hi Temp/Hi Drag for WECO HO 2x1½ & HO2x1	-450° to +850°F
PC3-33G	Reluctance Teflon Hi Output	+35° to +120°F
HE01S	Hall Effect Coil for HOG	-40° to +302°F
M-L3/8X1.52	Lo-Co Coil	-50° to +250°F

**HOFFER FLOW CONTROLS, INC.**  
 107 Kitty Hawk Lane, P. O. Box 2145, Elizabeth City, NC 27906-2145  
 800-628-4584 252-331-1997 FAX 252-331-2886  
 www.hofferflow.com email: info@hofferflow.com

*The specifications contained herein are subject to change without notice and any user of said specifications should verify from the manufacturer that the specification are currently in effect. Otherwise, the manufacturer assumes no responsibility for the use of specifications which may have been changed and are no longer in effect.*

The quality system covering the design, manufacture and testing of our products is certified to International Standard ISO 9001.

