

Nor-Mag
Magnetic AC/DC Powered
General Industrial Meters

USER'S MANUAL



HP-315
November 2010

H **HOFFER FLOW CONTROLS, INC.**
Perfecting Measurement™

107 Kitty Hawk Lane • P.O. Box 2145 • Elizabeth City, North Carolina 27906-2145
1-800-628-4584 • (252) 331-1997 • FAX (252) 331-2886
www.hofferflow.com • Email: info@hofferflow.com

Notice

HOFFER FLOW CONTROLS, INC. MAKES NO WARRANTY OF ANY KIND WITH REGARD TO THIS MATERIAL, INCLUDING, BUT NOT LIMITED TO, THE IMPLIED WARRANTIES OF MERCHANTABILITY AND FITNESS FOR A PARTICULAR PURPOSE.

This manual has been provided as an aid in installing, connecting, calibrating, operating, and servicing this unit. Every precaution for accuracy has been taken in the preparation of this manual; however, HOFFER FLOW CONTROLS, INC. neither assumes responsibility for any omissions or errors that may appear nor assumes liability for any damages that may result from the use of the products in accordance with information contained in the manual.

HOFFER FLOW CONTROLS' policy is to provide a user manual for each item supplied. Therefore, all applicable user manuals should be examined before attempting to install or otherwise connect a number of related subsystems.

During installation, care must be taken to select the correct interconnecting wiring drawing. The choice of an incorrect connection drawing may result in damage to the system and/or one of the components.

Please review the complete model number of each item to be connected and locate the appropriate manual(s) and/or drawing(s). Identify all model numbers exactly before making any connections. A number of options and accessories may be added to the main instrument, which are not shown on the basic user wiring. Consult the appropriate option or accessory user manual before connecting it to the system. In many cases, a system wiring drawing is available and may be requested from HOFFER FLOW CONTROLS.

This document contains proprietary information, which is protected by copyright. All rights are reserved. No part of this document may be photocopied, reproduced, or translated to another language without the prior written consent of HOFFER FLOW CONTROLS, INC.

HOFFER FLOW CONTROLS' policy is to make running changes, not model changes, whenever an improvement is possible. This affords our customers the latest in technology and engineering. The information contained in this document is subject to change.

RETURN REQUESTS / INQUIRIES

Direct all warranty and repair requests/inquiries to the Hoffer Flow Controls Customer Service Department, telephone number (252) 331-1997 or 1-800-628-4584. BEFORE RETURNING ANY PRODUCT(S) TO HOFFER FLOW CONTROLS, PURCHASER MUST OBTAIN A RETURNED MATERIAL AUTHORIZATION (RMA) NUMBER FROM HOFFER FLOW CONTROLS' CUSTOMER SERVICE DEPARTMENT (IN ORDER TO AVOID PROCESSING DELAYS). The assigned RMA number should then be marked on the outside of the return package and on any correspondence.

FOR **WARRANTY** RETURNS, please have the following information available BEFORE contacting HOFFER FLOW CONTROLS:

1. P.O. number under which the product was PURCHASED,
2. Model and serial number of the product under warranty, and
3. Repair instructions and/or specific problems relative to the product.

FOR **NON-WARRANTY** REPAIRS OR **CALIBRATIONS**, consult HOFFER FLOW CONTROLS for current repair/calibration charges. Have the following information available BEFORE contacting HOFFER FLOW CONTROLS:

1. P.O. number to cover the COST of the repair/calibration,
2. Model and serial number of the product, and
3. Repair instructions and/or specific problems relative to the product.

LIMITED WARRANTY

HOFFER FLOW CONTROLS, INC. ("HFC") warrants HFC's products ("goods") described in the specifications incorporated in this manual to be free from defects in material and workmanship under normal use and service, but only if such goods have been properly selected for the service intended, properly installed and properly operated and maintained. This warranty shall extend for a period of one (1) year from the date of delivery to the original purchaser (or eighteen (18) months if the delivery to the original purchaser occurred outside the continental United States). This warranty is extended only to the original purchaser ("Purchaser"). *Purchaser's sole and exclusive remedy is the repair and/or replacement of nonconforming goods as provided in the following paragraphs.*

In the event Purchaser believes the goods are defective, the goods must be returned to HFC, transportation prepaid by Purchaser, within twelve (12) months after delivery of goods (or eighteen (18) months for goods delivered outside the continental United States) for inspection by HFC. If HFC's inspection determines that the workmanship or materials are defective, the goods will be either repaired or replaced, at HFC's sole determination, free of additional charge, and the goods will be returned, transportation paid by HFC, using the lowest cost transportation available.

Prior to returning the goods to HFC, Purchaser must obtain a Returned Material Authorization (RMA) Number from HFC's Customer Service Department within 30 days after discovery of a purported breach of warranty, but no later than the warranty period; otherwise, such claims shall be deemed waived. See the Return Requests/Inquiries Section of this manual. If HFC's inspection reveals the goods are free of defects in material and workmanship or such inspection reveals the goods were improperly used, improperly installed, and/or improperly selected for service intended, HFC will notify the purchaser in writing and will deliver the goods back to Purchaser upon (i) receipt of Purchaser's written instructions and (ii) the cost of transportation. If Purchaser does not respond within thirty (30) days after notice from HFC, the goods will be disposed of in HFC's discretion.

HFC does not warrant these goods to meet the requirements of any safety code of any state, municipality, or other jurisdiction, and Purchaser assumes all risk and liability whatsoever resulting from the use thereof, whether used singly or in combination with other machines or apparatus.

This warranty shall not apply to any HFC goods or parts thereof, which have been repaired outside HFC's factory or altered in any way, or have been subject to misuse, negligence, or accident, or have not been operated in accordance with HFC's printed instructions or have been operated under conditions more severe than, or otherwise exceeding, those set forth in the specifications for such goods.

THIS WARRANTY IS EXPRESSLY IN LIEU OF ALL OTHER WARRANTIES, EXPRESSED OR IMPLIED, INCLUDING ANY IMPLIED WARRANTY OF MERCHANTABILITY OR FITNESS FOR A PARTICULAR PURPOSE. HFC SHALL NOT BE LIABLE FOR ANY LOSS OR DAMAGE RESULTING, DIRECTLY OR INDIRECTLY, FROM THE USE OR LOSS OF USE OF THE GOODS. WITHOUT LIMITING THE GENERALITY OF THE FOREGOING, THIS EXCLUSION FROM LIABILITY EMBRACES THE PURCHASER'S EXPENSES FOR DOWNTIME OR FOR MAKING UP DOWNTIME, DAMAGES FOR WHICH THE PURCHASER MAY BE LIABLE TO OTHER PERSONS, DAMAGES TO PROPERTY, AND INJURY TO OR DEATH OF ANY PERSONS. HFC NEITHER ASSUMES NOR AUTHORIZES ANY PERSON TO ASSUME FOR IT ANY OTHER LIABILITY IN CONNECTION WITH THE SALE OR USE OF HFC'S GOODS, AND THERE ARE NO ORAL AGREEMENTS OR WARRANTIES COLLATERAL TO OR AFFECTING THE AGREEMENT. *PURCHASER'S SOLE AND EXCLUSIVE REMEDY IS THE REPAIR AND/OR REPLACEMENT OF NONCONFORMING GOODS AS PROVIDED IN THE PRECEDING PARAGRAPHS. HFC SHALL NOT BE LIABLE FOR ANY OTHER DAMAGES WHATSOEVER INCLUDING INDIRECT, INCIDENTAL, OR CONSEQUENTIAL DAMAGES.*

Disclaimer

Specifications are subject to change without notice.
Some pages are left intentionally blank.

Content

1. APPLICATION.....	1
2. MEASUREMENT PRINCIPLE.....	1
3. TECHNICAL DESCRIPTION.....	2
3.1. GENERAL	2
3.2. METER DESIGN.....	3
3.2.1. Distributed Version	3
3.2.2. Compact Version	4
3.2.3. Protection of commercial meters against unauthorised handling.....	5
3.2. MODEL NUMBER DESIGNATION.....	6
4. TECHNICAL PARAMETERS	8
4.1. FLOW SENSOR.....	8
4.1.1. Selection of correct sensor size	8
4.1.2. Operational pressure of measured liquid	9
4.1.3. Selection of electrode material	10
4.1.4. Selection of sensor tube lining.....	10
4.1.5. Compact or distributed meter version?	10
4.1.6. Dimensions of flanged sensor	11
4.1.7. Dimensions of flangeless sensor	12
4.1.8. Flow sensor specifications.....	13
4.2. ELECTRONIC UNIT BOX.....	13
4.2.1. Electronic unit specifications.....	14
5. METER APPLICATION RULES	15
5.1. SENSOR PLACEMENT IN PIPING	15
5.2. SENSOR EARTHING	17
6. LOW METER INSTALLATION AND OPERATIONAL START	18
6.1. SENSOR INSTALLATION	18
6.2. ELECTRIC CONNECTIONS OF INDUCTION FLOW METER.....	19
6.2.1. Connection to Power Source	19
6.2.2. Output Signal Connections	20
6.3. CONNECTION BETWEEN SENSOR AND ELECTRONIC UNIT (DISTRIBUTED METER VERSION).....	20
6.4. CONNECTION BETWEEN SENSOR AND ELECTRONIC UNIT(DISTRIBUTED METER VERSION, PROTECTION CLASS IP 68).....	20
6.5. OPERATIONAL START	21
6.5.1. The ECONOMIC version	21
6.5.2. The COMFORT version.....	21
6.5.3. Operational data	21
6.5.3.1. Display formats of aggregate values	24
6.5.3.2. Data reset	25
7. ROGRAMMING	25
7.1. PROGRAMMING OF THE BASIC MENU ITEMS.....	26
7.1.1. Displayed data.....	26
7.1.2. Samples	28
7.1.3. Analog output	28

7.1.4.	Output functions.....	31
7.1.5.	Electrode cleaning	38
7.1.6.	Serial line	38
7.1.7.	Production data.....	40
7.1.8.	Dose setting.....	43
7.1.9.	Zero setting.....	43
7.1.10.	100 per cent.....	44
7.1.11.	Exit	44
7.2.	THE PARAMETER SETTING MENU.....	46
7.3.	THE PRODUCTION DATA MENU.....	47
8.	ERROR CLEARING AND METER REPAIR PROCEDURES.....	48
8.1.	REPLACEMENT PC BOARDS	48
8.2.	PROGRAM AND SIMULATION SOFTWARE	48
8.3.	FLOW-METER REPAIR PROCEDURE	48
8.3.1.	KV 1.0 Fixture for checking the meter outputs.....	51
8.3.2.	Checking the condition of flow-meter sensor (the compact meter version).....	52
8.3.2.1.	Measurements to be performed on sensor with no fluid inside (the lining is dry)	52
8.3.2.2.	Checking the condition of flow-meter sensor fitted into piping and flooded with the measured fluid	53
8.3.3.	Checking the condition of flow-meter sensor (the distributed meter version with the remote Electronic unit accommodated with an IP-67 box).....	54
8.3.3.1.	Measurements to be performed on sensor with no fluid inside (the lining is dry)	54
8.3.3.2.	Checking the condition of flow-meter sensor fitted into piping and flooded with the measured fluid.....	55
8.3.3.3.	Checking the condition of the cable connecting sensor and associated electronic unit	56
8.3.4.	Checking the condition of flow-meter sensor (the distributed meter version with the remote electronic unit accommodated in an IP-68 box)	57
8.3.4.1.	Checking the condition of flow-meter sensor fitted into piping and flooded with the measured fluid.....	58
8.3.5.	Checking the condition of induction flow meter using the meter diagnostic module of the Floset 2.0 program.....	59

1. APPLICATION

The NORMAG induction flow meter has been designed to measure volume flow rates of electrically conductive liquids in closed piping systems. Measurements can be done in both flow directions, with high measurement accuracy over a wide range of flow rates (0.1 to 10 m/s). The minimum required conductivity of the measured medium is 5 $\mu\text{S}/\text{cm}$.

The signal-processing electronic unit includes a two-line alphanumeric display to show the measured values where various operational parameters of the meter can be selected by means of an associated keyboard. Available are two passive binary outputs (indicating frequency, impulse and/or specified limit values), one active current output and an output to connect a digital communication line. All meter functions and output parameters can be reset during the meter operation. If the meter is to be used as a commercial (invoicing) meter, some of its functions are blocked to prevent the user from interfering with the meter readings.

Should the need arise, the user may combine any sensor of the IS X.XX type series with any electronic unit (C 6.00 or C 7.00) without re-calibration of the meter on a test stand (however, such calibration is required for commercial meters). The only thing that needs be done is to enter into the electronic unit memory the calibration constants and excitation frequency of the selected sensor; these data are given on the rating plate of the sensor. The value of threshold flow rate shall be set between 0.5 and 1% of the specified maximum flow rate.

2. MEASUREMENT PRINCIPLE

The function of an induction flow meter is based on Faraday's induction law. The meter sensor consists of a non-magnetic and non-conductive tube with two embedded measuring electrodes to pick up the induced voltage. To create an alternating magnetic field, two coils are fitted onto the tube in parallel with the plane defined by the active parts of the measuring electrodes. Now if a conductive liquid flows across magnetic field **B**, voltage **U** will appear on the measuring electrodes proportional to the flow velocity **v** and the conductor length **l**.

$$\mathbf{U} = \mathbf{B} \times \mathbf{l} \times \mathbf{v}$$

- U** induced voltage
- B** magnetic flux density
- l** distance between the measuring electrodes
- v** liquid flow velocity

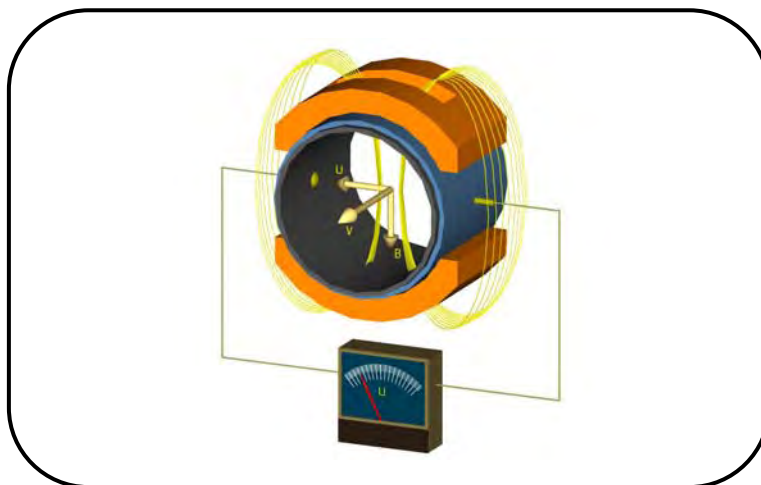

As the magnetic flux density and distance between the electrodes are constant, the induced voltage is proportional to the liquid flow velocity in the tube. The value of the volume flow rate can then be readily determined as a product of the flow velocity and square section of the tube, $\mathbf{Q} = \mathbf{v} \times \mathbf{S}$.

3. TECHNICAL DESCRIPTION

3.1. General

The induction flow meter consists of a sensor through which the measured liquid flows, and an electronic unit where the low-level signal from the sensor is modified to a standardised form suitable for further processing in various industrial electronic devices. The output signal is proportional to the volume flow rate of the measured liquid. The only factor limiting the application of induction flow meters is the requirement that the measured liquid shall be conductive and non-magnetic. The induction flow meter can be designed either as a compact device or with the sensor separated from the associated electronic unit. In the former case, the electronic unit is fitted directly onto the meter sensor, in the latter case it is connected to the sensor by a special cable.

The sensor design shall take into consideration the type of the measured liquid and its operational parameters. To facilitate fitting into the liquid piping, the sensor can be provided with end flanges, screwing, or it may be of a sandwich design. The electronic unit is supplied in two basic versions, COMFORT or ECONOMIC. The supply voltage, types of output signal and communication interface can be selected according to the customer requirements.

The basic configuration of the induction flow meter includes two insulated passive binary outputs (each with an optocoupler including a transistor output) and the USB communication interface. This interface is not insulated as it is used for calibration purposes only. Optional accessories to this basic configuration are insulated current output and insulated RS 485 communication interface, output relay, INPUT1 and OUTPUT3 for batching (all these electrically insulated from the electronic unit circuitry).

3.2. Meter Design

3.2.1. Distributed Version

Flanged sensor connected by a cable with the associated separate electronic unit.

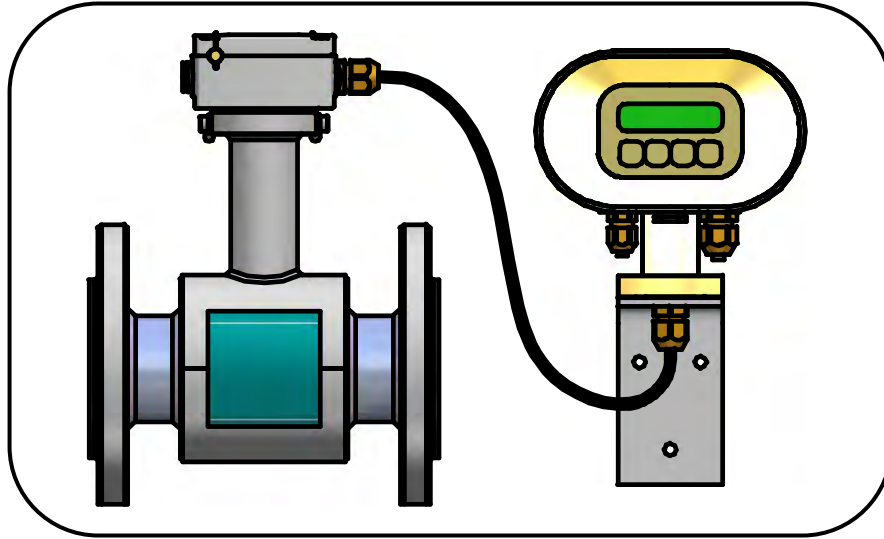

Dimensions of the box to accommodate separate electronic unit and the mounting bracket

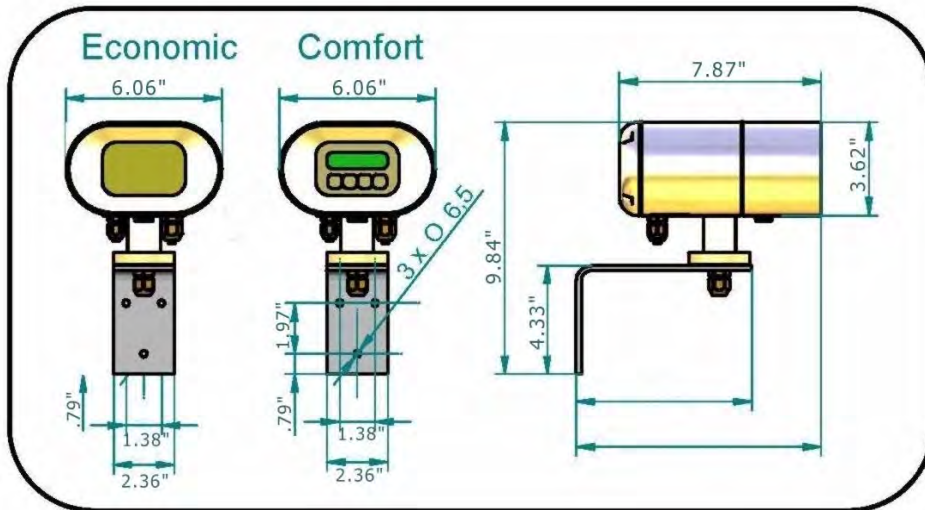

3.2.2. Compact Version

Compact design solution for a flanged sensor with associated electronic unit

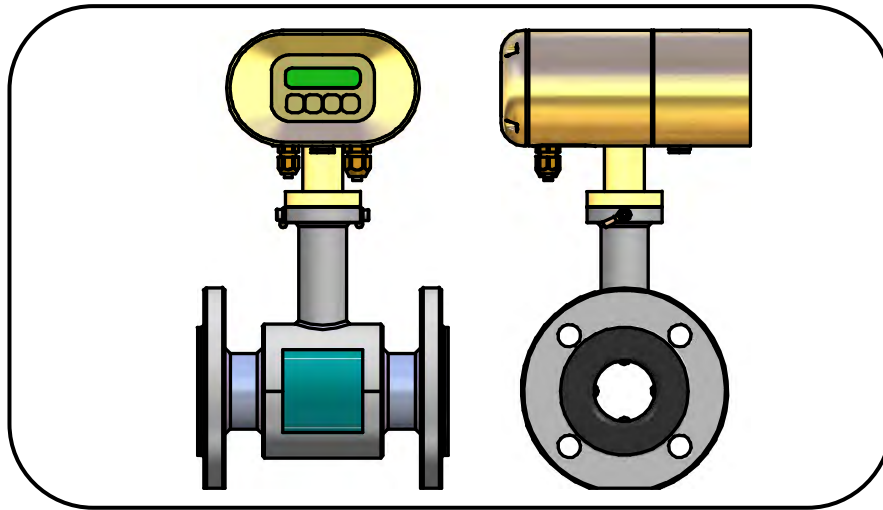

Compact design solution for a flangeless sensor and associated electronic unit

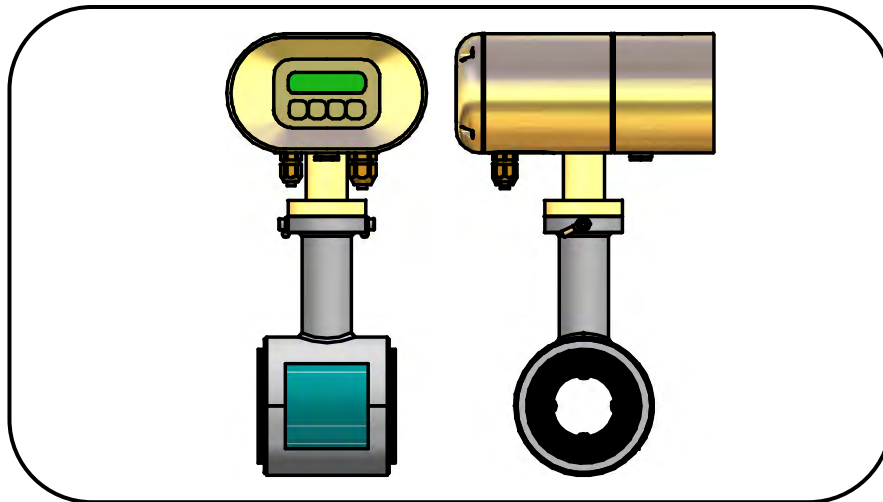

Dimensions of the box to accommodate the flow meter in the compact design version

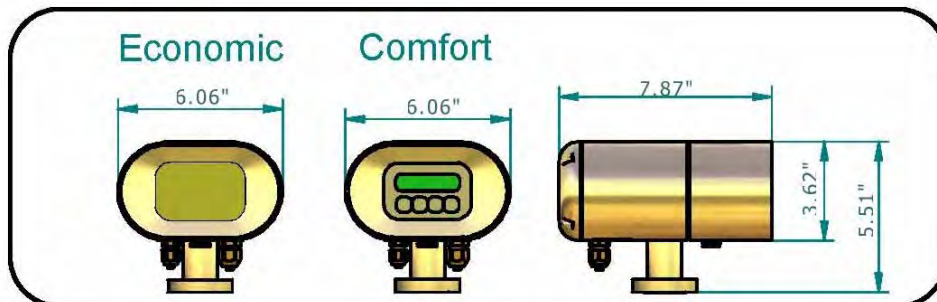

3.2.3. Protection of commercial meters against unauthorised handling

If the meter is to serve commercial purposes, it shall be provided with official and assembly seals. Installation of commercial meters is reserved to duly authorised organisation(s).

Placement of official and assembly seals on meters in compact and distributed versions.

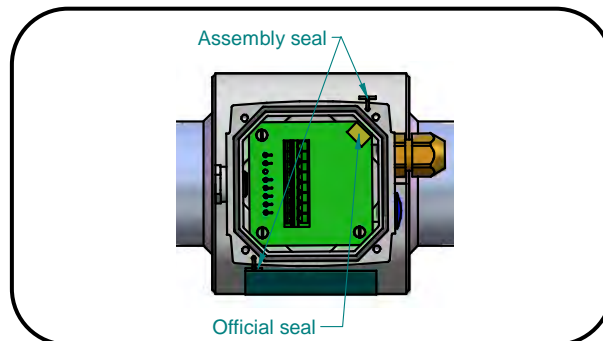
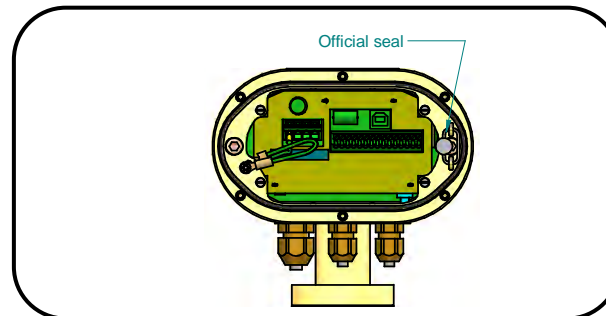
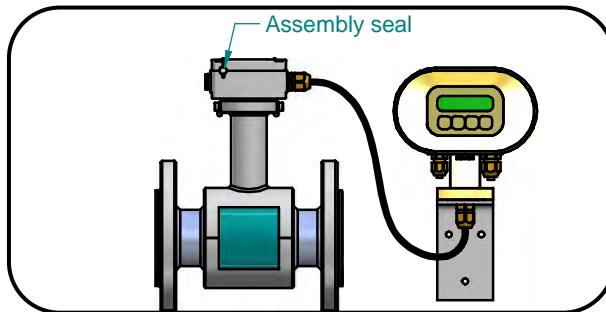
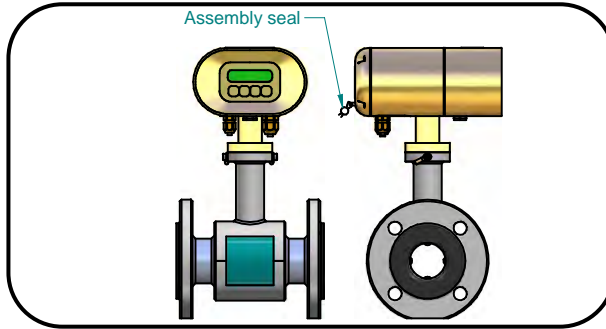

3.2. Model Number Designation

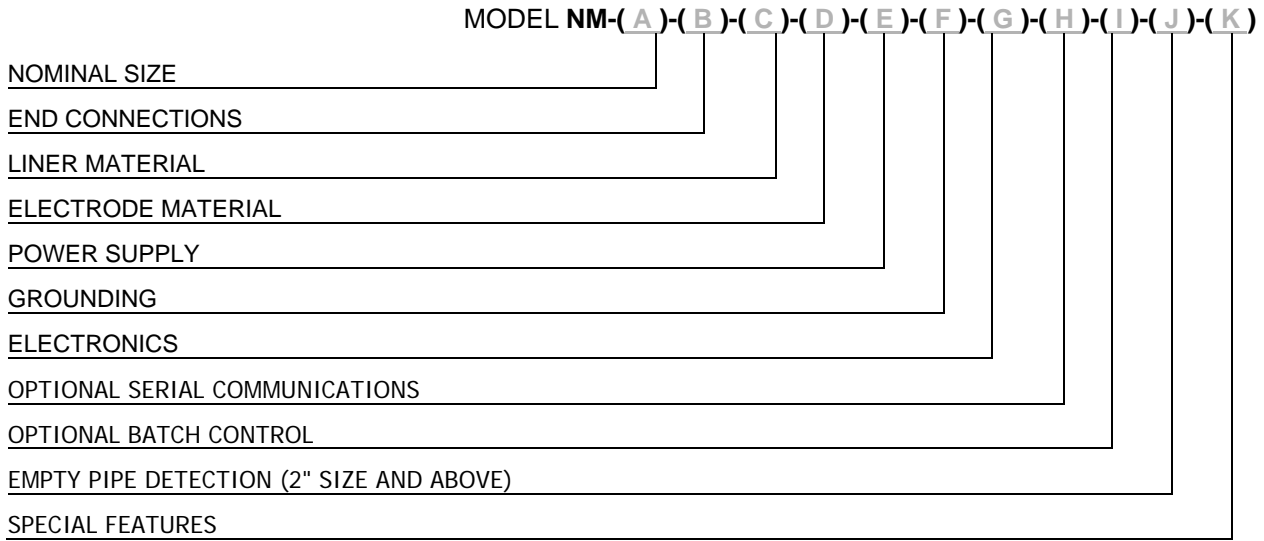

NOMINAL SIZE

MODEL NM-(A)-()-()-()-()-()-()-()-()-()-()-()

SIZE (A):	1/2"	3"
	3/4"	4"
	1"	5"
	1 1/4"	6"
	1 1/2"	8"
	2"	10"
	2 1/2"	12"

END CONNECTION

MODEL NM-()-(B)-()-()-()-()-()-()-()-()-()-()

OPTION (B)

- (FICS) RF ANSI 150# CARBON STEEL (CS)
- (F1SS) RF ANSI 150# STAINLESS STEEL (SS)
- (W1CS) WAFER STYLE, FOR ANSI RF 150# CS

LINER MATERIAL

MODEL NM-()-()-(C)-()-()-()-()-()-()-()-()-()

OPTION (C)

- (1) SOFT RUBBER (176°F MAX)
- (2) HARD RUBBER (176°F MAX)
- (3) HIGH TEMP. RUBBER (194°F MAX)
- (4) PTFE TEFLON (300°F MAX), 1/2" THRU 8" SIZES
- (5) E-CTFE (266°F MAX), 10" AND 12" SIZES ONLY

ELECTRODE MATERIAL

MODEL NM-()-()-()-(D)-()-()-()-()-()-()-()-()

OPTION (D)

- (1) STAINLESS STEEL
- (2) HASTELLOY
- (3) OTHER

POWER SUPPLY

MODEL NM-()-()-()-()-(E)-()-()-()-()-()

OPTION (E)

- (1) 24 VDC STANDARD
- (2) 115 VAC
- (3) 220 VAC

GROUNDING

MODEL NM-()-()-()-()-()-(F)-()-()-()-()-()

OPTIONS (F)

- (1) STAINLESS STEEL GROUNDED ELECTRODES
- (2) STAINLESS STEEL GROUNDING RINGS:

1/2"	4"
3/4"	5"
1" & 1/4"	6"
1 1/2"	8"
2"	10"
2 1/2"	12"
3"	

- (3) HASTELLOY GROUNDED ELECTRODES
- (4) HASTELLOY GROUNDING RINGS
- (5) OTHER

ELECTRONICS

MODEL NM-()-()-()-()-()-()-(G)-()-()-()-()

OPTIONS (G)

- (1) INTEGRAL RATE AND TOTAL INDICATOR WITH FACE MOUNTED CONTROLS, IP 67
- (2) REMOTE ELECTRONICS FOR IP 67 WITH 19-FT CABLE
- (3) REMOTE ELECTRONICS FOR IP 68 WITH 19-FT CABLE

OPTIONAL SERIAL COMMUNICATIONS

MODEL NM-()-()-()-()-()-()-(H)-()-()-()-()

OPTIONS (H)

- (1) RS485 SERIAL COMMUNICATION

OPTIONAL BATCH CONTROL

MODEL NM-()-()-()-()-()-()-()-()-(I)-()-()

OPTIONS (I)

- (1) BATCH CONTROL FUNCTION

EMPTY PIPE DETECTION (2" SIZE AND ABOVE)

MODEL NM-()-()-()-()-()-()-()-()-(J)-()-()

OPTIONS (J)

- (1) FOR USE WITH SS ELECTRODES
- (2) FOR SE WITH HASTELLOY C ELECTRODES

SPECIAL FEATURES

MODEL NM-()-()-()-()-()-()-()-()-()-()-(K)

OPTIONS (K)

- (X)

ADDITIONAL CABLE LENGTHS

UP TO 150 FT FOR REMOTE IP 67 OPTION AND REMOTE IP 68 OPTION

4. TECHNICAL PARAMETERS

4.1. Flow Sensor

The sensor environment must be free of any strong magnetic fields.

4.1.1. Selection of correct sensor size

The following table shows minimum and maximum flow rates for various sensor sizes and flow velocities ranging from 0.1 to 10 m/s. The best operational properties will be achieved at the flow-velocity range of 0.5 to 5 m/s. For lower flow velocities, the measurement accuracy is worse while at higher flow velocities the turbulences at contact edges may cause undesirable interference.

Minimum and maximum flow rates for various sensor sizes

Qmin corresponds to flow velocity 0.1 m/s

Qmax corresponds to flow velocity 10.0 m/s

Diameters Inches	LPM		GPM	
	Qmin	Qmax	Qmin	Qmax
1/2"	1.08	108	.29	28.62
3/4"	2	200	.53	52.83
1"	3	300	.79	79.25
1 1/4"	5	500	1.32	132.09
1 1/2"	7.5	750	1.98	198.13
2"	12	1,200	3.17	317.01
2 1/2"	20	2,000	5.28	528.34
3"	30	3,000	7.92	792.52
4"	42	4,666	13.3	1,232.8
5"	72	7,166	18.9	189
6"	108	10,433	29	2,862
8"	191.6	19,164	51	5,063
10"	300	30,000	79	7,925
12"	420	42,000	111	11,095
14"	583.2	38,320	154	15,410
16"	750	75,000	198	19,813
20"	1,200	120,000	317	31,701
24"	1,667	166,680	440	44,028
28"	2,333	233,340	616	61,640
32"	3,000	300,000	793	79,252
36"	3,633	383,340	1,013	101,266
40"	4,667	466,680	1,233	123,280
48"	6,667	666,660	1,761	176,110

Operational flow rates and flow velocities for various sensor sizes

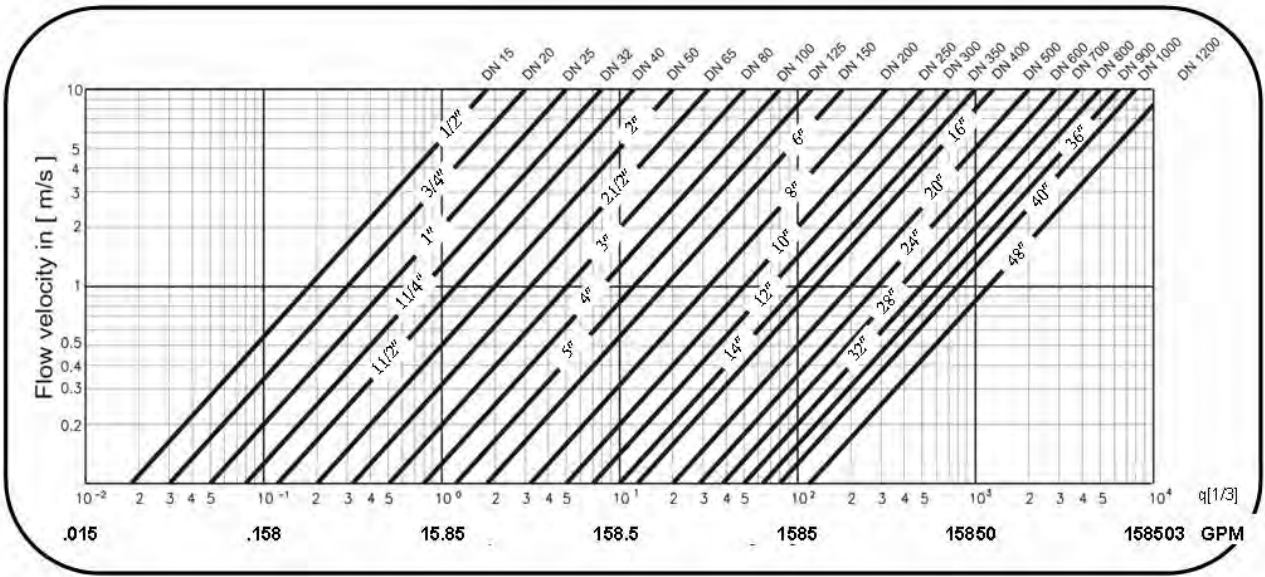

4.1.2. Operational pressure of measured liquid

The standard flow-sensor versions have the following pressure ratings:

Sensor Size Diameter Inches (DN)		Pressure rating	
DN 15 – DN 40	1/2" - 1 1/2"	PN 40 (4.0MPa)	580 PSI
DN 50 – DN 200	2" - 8"	PN 16 (1.6MPa)	232 PSI
DN 250 – DN 750	10" - 29"	PN 10 (1.0MPa)	145 PSI
DN 800 – DN 1200	32" - 48"	PN 6 (0.6MPa)	87 PSI

On request, any sensor can be supplied for rated operational pressure 87 PSI to 580 PSI. The choice of rated pressure is primarily derived from the maximum operational pressure of the measured liquid, taking into account the size of the flanges on the associated piping. Consideration shall also be given to the liquid temperature.

Relationship between operational pressure and temperature of the measured liquid

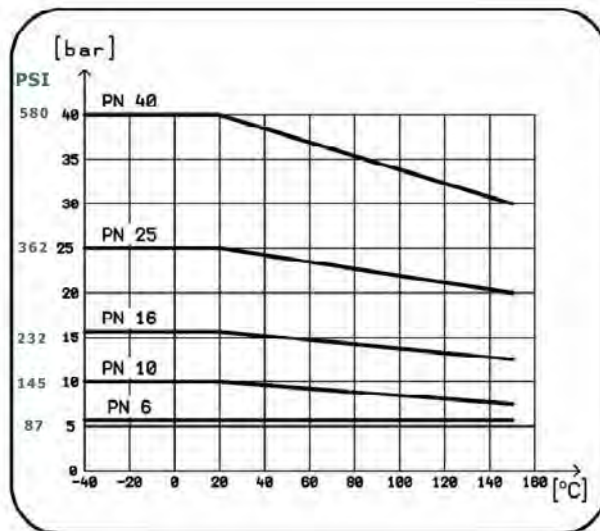

4.1.3. Selection of electrode material

In most cases, electrodes made of stainless steel, quality grade 1.4571 (17248) are satisfactory. However, in special applications it may be necessary to select a higher-quality material. On request, the meter manufacturer may supply electrodes made of platinum, tantalum, titanium or Hastelloy C4.

4.1.4. Selection of sensor tube lining

The sensor lining material selection depends on the operational parameters of the measured liquid.

Technical rubber

This lining material is suitable for less corrosive liquids and operational temperatures between 32 and +176°F. It is sufficient for most applications in water supply and waste water treatment plants. Technical rubber is available in two grades: HR – hard rubber and SR – soft rubber. Soft rubber lining is recommended for liquids containing abrasive particles, such as sand grains.

Resistant rubber

Designated SPR, resistant (heavy-duty) rubber is recommended for use with liquids of medium corrosiveness and operational temperatures between 32 and +194°F. It is suitable for flow measurements of technical water, condensate and in similar applications. Where the temperatures are likely to exceed +212°F, it is safer to use Teflon lining.

Teflon

Teflon (PTFE) lining is a universal solution for highly corrosive liquids and temperatures ranging from –4 to +302°F. Typical applications are in the chemical and food processing industries.

E-CTFE

E-CTFE lining is a universal solution for flow meters from (12") and higher for corrosive liquids and temperatures ranging from -4 to +255°F. Typical applications are in the chemical processing industries.

4.1.5. Compact or distributed meter version?

The distributed meter version is to be used at the measurement spots with ambient temperature exceeding 122°F where the reliable function of the electronic unit would not be ensured at all times. In such cases, use the distributed meter version and place the separate electronic unit at a location where the ambient temperature never exceeds 122°F.

To prevent electromagnetic interference via the connecting cable, the sensor and separate electronic unit of the meter in the distributed version should be located as close as possible to one another. The maximum cable length depends on the conductivity of the measured liquid (see the following diagram).

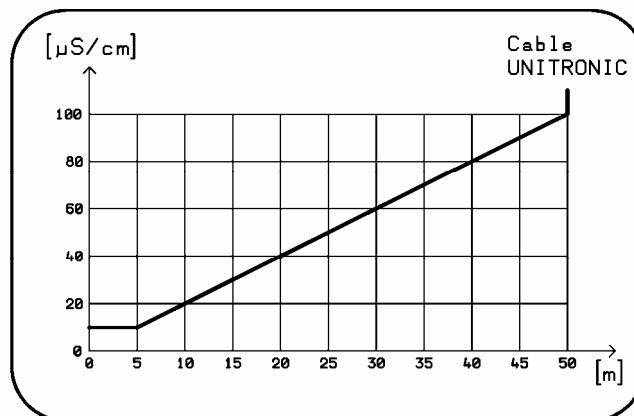

4.1.6. Dimensions of flanged sensor

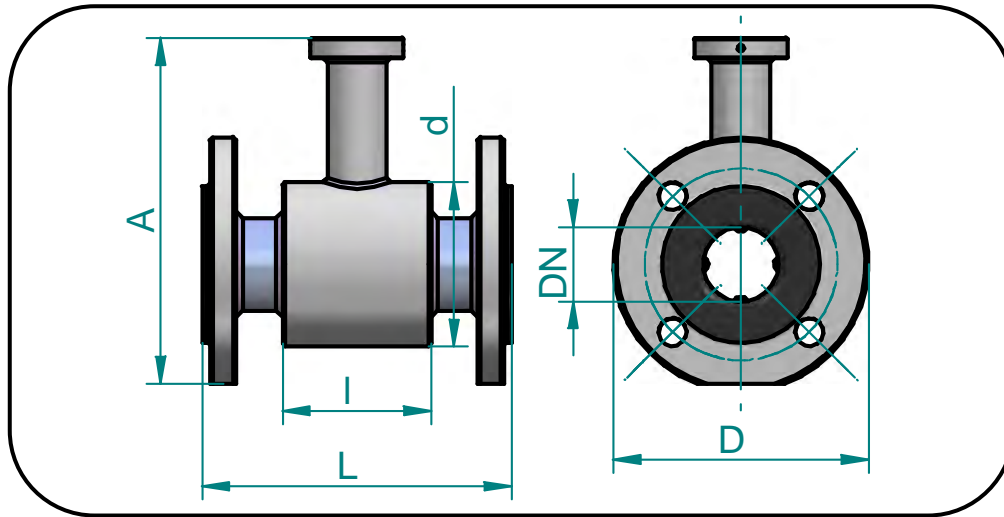

Sensor dimensions for various rated diameters (DN)

Flanges according to standard EN 1092-1.

	DN	D	d	A*	L	l	Weight [lbs]
PN 40 (580 PSI)	1/2"	4"	2"	6"	8"	2.5"	7
	3/4"	4"	2"	7"	8"	2.5"	7
	1"	4.5"	3"	7"	8"	27"	7
	1 1/4"	5.5"	3"	8"	8"	27"	9
	1 1/2"	6"	4"	8"	8"	27"	9
PN 16 (232 PSI)	2"	6.5"	4"	9"	8"	27"	13
	2 1/2"	7"	5"	10"	8"	27"	20
	3"	8"	5.5"	10"	8"	27"	31
	4"	9"	6"	11"	10"	27"	35
	5"	10"	7.5"	12"	10"	5"	42
	6"	11"	8.5"	13"	12"	5"	55
	8"	13"	11"	16"	14"	8"	91
PN 10 (145 PSI)	10"	17.5"	14.5"	19"	18"	8"	119
	12"	17.5"	16.5"	21"	20"	12.5"	170
	14"	20"	19"	23"	22"	12.5"	203
	16"	22"	21"	25"	24"	12.5"	256
	20"	26"	25"	30"	24"	12.5"	368
	24"	31"	30"	34"	24"	12.5"	694
	28"	35"	35"	39"	28"	16.5"	
PN 6 (87 PSI)	32"	38"	38"	43"	31"	16.5"	941
	36"	42"	41"	47"	35"	20"	
	40"	46"	49"	51"	39"	20"	1102
	48"	55"	53"	59"	47"	20"	1499

*Dimension A (sensor height) is net of the electronic unit box (or terminal box in the distributed meter version).

The sensor weight data are only approximate.

4.1.7. Dimensions of flangeless sensor

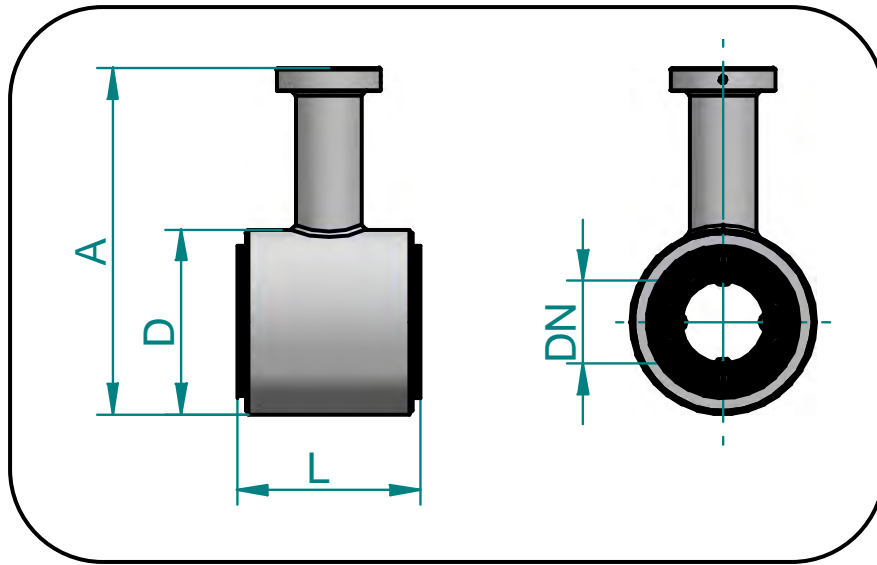

Flangeless sensor dimensions for various rated diameters (DN)

	DN	D	A*	L	Weight [lbs]
PN 40 (580 PSI)	.8"	2"	6"	3"	2
	.9"	3"	6"	4"	4
	1"	3"	7"	4"	4
	1.5"	4"	7"	4"	4
PN 16 (232 PSI)	2"	4"	7.5"	4"	7
	2"	5"	8"	4"	7
	3"	5.5"	9"	4"	9
	4"	6"	10"	4"	9
	5"	7.5"	11"	5"	13
	6"	8.5"	12"	5"	18
	8"	11"	14"	9"	22

* Dimension A (sensor height) is net of the electronic unit box (or terminal box).
The sensor weight data are only approximate.

4.1.8. Flow sensor specifications

Sensor size	Flanged sensors, DN 1/2" to DN 47" Flangeless sensors, DN 4/5" to DN 8"
Operational pressure	PN 40 (4.0MPa) for DN 1/2" to 1.5" PN 16 (1.6MPa) for DN 2" to 8" PN 10 (1.0MPa) for DN 10" to 29.5" PN 6 (0.6MPa) for DN 31" to 47"
Mechanical connection	Flanges according to ČSN, EN or DIN standards Flangeless Others
Earthing	On flanges Earthing rings Earthing electrode
Flow velocity of measured liquid	From 0.1 m/s to 10 m/s
Maximum temperature of measured liquid	Up to 302°F (according used lining)
Minimum conductivity of measured liquid	20 µS/cm, 5 µS/cm in special applications
Empty pipe alarm	From DN 2"
Lining	Soft rubber Hard rubber Resistant rubber Teflon (PTFE) E-CTFE
Measuring electrodes	Stainless steel, grade 1.4571 (17248) Hastelloy C4 Platinum Tantalum Titanium
Protection class	IP 67 IP 68
Storage temperature	-14°F to +158°F at max. relative air humidity 70%

4.2. Electronic Unit Box

The signal-processing electronic unit is accommodated in a cast aluminium box coated on the surface with paint of hue RAL 1017. The box is held by four M5 bolts with hexagonal socket heads. Upon loosening the bolts slightly the box can be rotated around horizontal axis through $\pm 180^\circ$. At the rear part of the box there is a terminal board under a lid held in position by six bolts with hexagonal socket heads. At the bottom of the box there are cable glands and a special valve preventing condensation of the air humidity inside the box. The unused gland openings shall be blinded. The front panel of the box is either blinded (the ECONOMIC version) or fitted with a two-line background-illuminated display unit and a four-button membrane keyboard (the COMFORT version of the meter).

Prior to putting the meter in service, check the correct sealing of all active glands, blinding of the unused ones and tightening of the bolts holding the terminal board lid.

4.2.1. Electronic unit specifications

Line Sizes:	1/2" to 12" (Available up to 48") (DN 15-1200)
Nominal Pressure:	ANSI 150#, 300#, 600# Max Pressure—Size Dependant
Minimum Conductivity of measured Liquid:	20 μ S/cm, on agreement with the manufacturer down to 5 μ S/cm
Electrode Material:	Stainless steel, Hastelloy-C4, platinum, tantalum
Ambient Temperature:	23°F to 131°F (-5°C to 55°C)
Sensor Lining:	Soft or hard rubber, Teflon
Design Version:	Electronics Meter Mounted or Remote Mounted
Piping Connection:	Flanges or Wafer
Max. Temperature of Measured Liquid:	Up to 311°F (155°C), depending on sensor lining
Measurement Accuracy :	\pm 0.2% for 10 to 100% \pm 0.5% for 5 to 100%
Measuring Range:	0.1 to 10 m/s
Indication of Empty Piping:	From 2" DN 50 Upwards
Displayed Units	Gallons, Liters, Cubic Meters
Outputs (insulated):	Current (0) 4 to 20mA Frequency 0 to 1,000 Hz Pulse, 0.001 to 1,000 liters per pulse Communication line USB, RS 485
Power Supply:	24/115/230V \pm 10%, 50 to 60 Hz (AC), 24V \pm 10% (DC)
Protection Class	IP67 (IP68)*

5. METER APPLICATION RULES

5.1. Sensor Placement in Piping

No chemical injection or batching unit (such as chlorine compound injector) should be located at the input side of the sensor. The insufficient homogeneity of the flowing liquid may affect the flow-rate values indicated by the meter.

The meter performance will be the best if the liquid flow in the piping is well stabilised; therefore it is necessary to observe specific rules for the sensor placement in piping. In the contact planes between the sensor and the adjoining piping sections should be no edges as these would cause flow turbulence. Make sure that straight piping sections are provided before and after the sensor; their required length is proportional to the inner diameter of the piping concerned.

If more than one flow-disturbing element such as pipe bend or fitting are located near the sensor, the required length of straight piping section on the sensor side concerned should be multiplied by the quantity of such elements.

As required by clause 4.2.1 of standard EN 29104, the inner diameter of the connected pipe should not differ by more than 3% from that of the sensor.

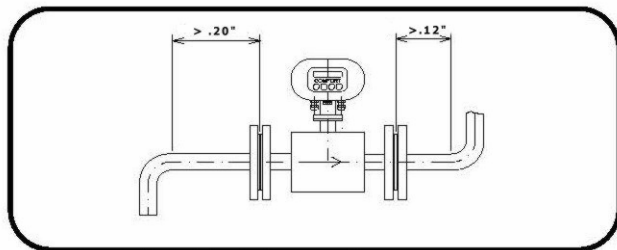

Required straight piping sections

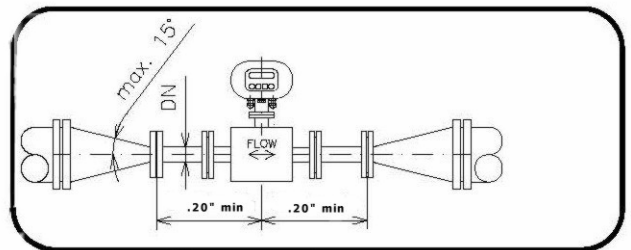

Pipe narrowing

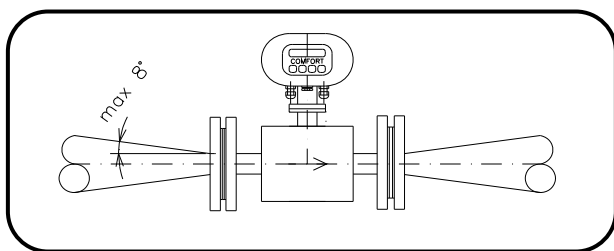

In the cases where the pipe size larger than that of the meter sensor, it is necessary to use conical reduction pieces with the angle of taper not exceeding 15° (see the picture). In the cases of bi-directional flow measurement, the minimum length of straight piping sections on both sides is 5 DN. In horizontal sensor installations, to prevent bubbling, use eccentrically-fitted reduction pieces (see standard ČSN EN ISO 6817).

Pipe narrowing sections with angles not exceeding 8° can be taken for straight sections.

In the cases where the liquid is pumped, the flow sensor shall always be placed at the output side of the pump to prevent underpressure in the piping which might damage the sensor. The required length of the straight piping section between the pump and sensor is then at least 25 DN.

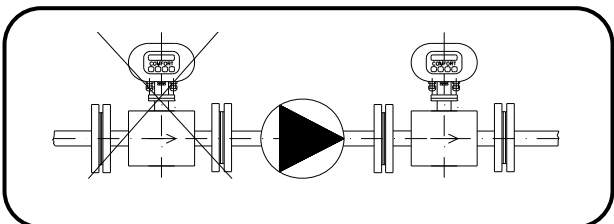

Pump in the piping

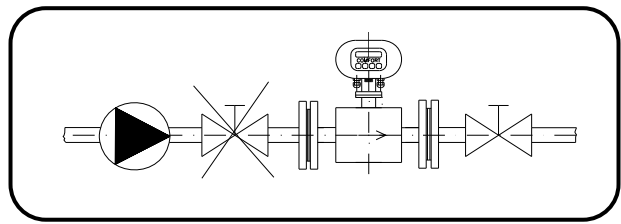

Closing valve in the piping

For the same reason, the sensor shall be always placed before the closing valve in the piping.

The sensor can be fitted in the piping in either horizontal or vertical position. However, make sure that the electrode axis is always horizontal and, if the sensor is mounted in a horizontal position, the flange section for attachment of the electronic unit box faces upwards.

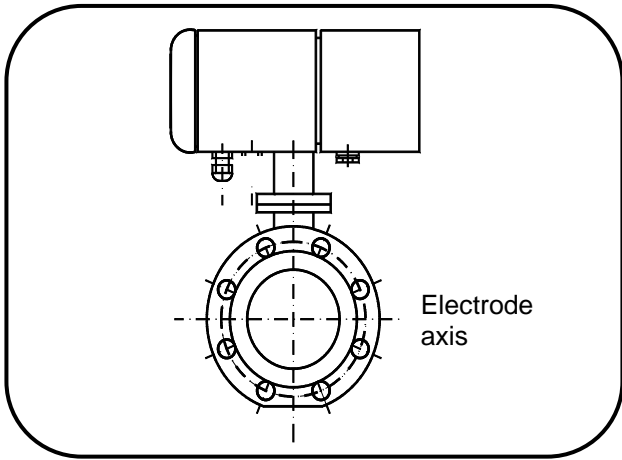

Electrode axis

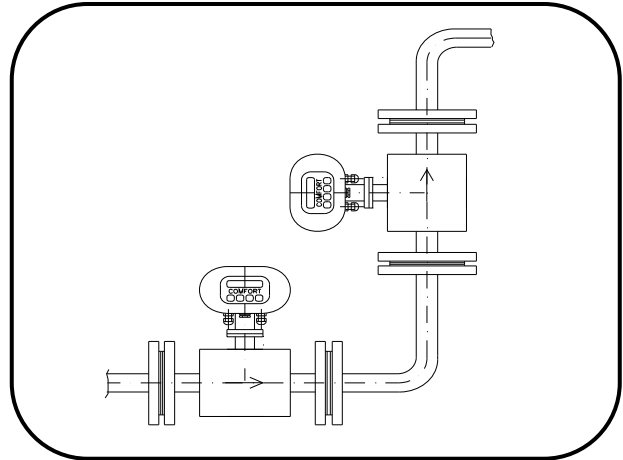

Sensor mounted in a vertical position

In the cases where the sensor is mounted in a vertical position, the flow direction shall always be upwards.

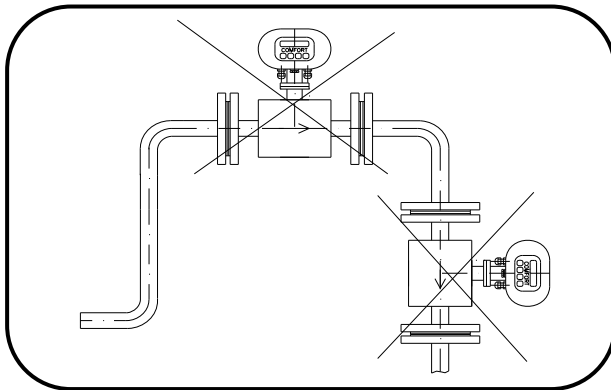

Risk of liquid aeration

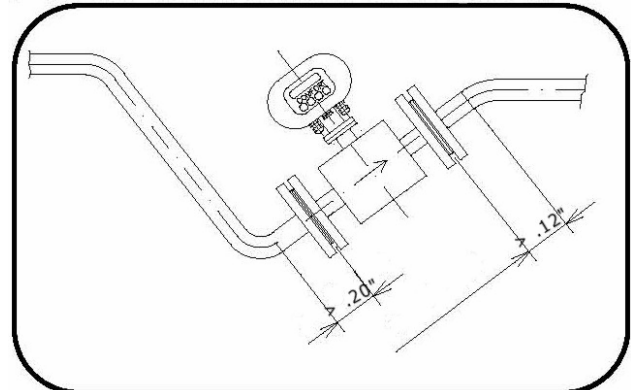

Permanent flooding of sensor

To ensure correct meter function at all times, the measured liquid shall completely fill up the sensor and no air bubbles shall be permitted to accumulate or develop in the sensor tube. Therefore the sensor shall never be placed in the upper pocket of the piping or in a vertical piping section where the flow direction is downwards. In piping systems where complete flooding of the piping cannot always be guaranteed, consider placing the sensor in a bottom pocket where full flooding is ensured.

If the sensor is located near a free discharge point, such point shall be by at least 2 DN higher than the top part of the sensor.

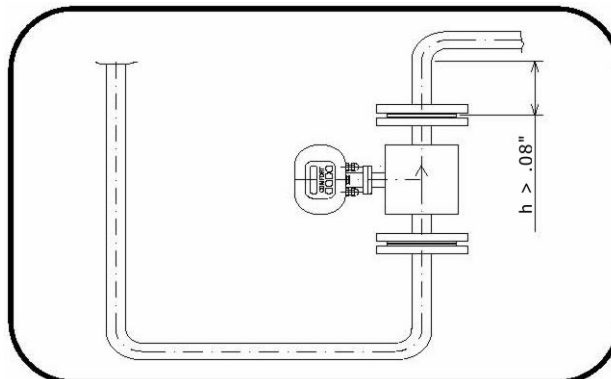

Sensor placement near free discharge point

Make sure that the adjoining piping is clamped/supported as close to the sensor as possible, to prevent vibrations and damage to the sensor.

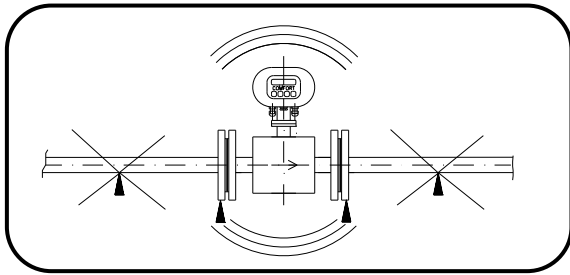

Undesirable sensor vibrations

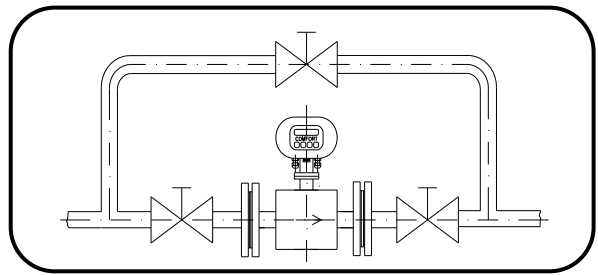

Sensor bypass

In applications where continuous liquid flow is essential, a bypass shall be provided to allow for sensor servicing. A sensor bypass may also be a reasonable solution in the cases where, to dismantle the flow sensor from the piping, liquid from a very long piping section would have to be discharged.

5.2. Sensor Earthing

The correct meter function requires that the sensor and adjoining piping sections be connected by low-impedance earthing conductors to the earth potential and the protection conductor of the power source. The overall arrangement shall be such that the potentials of the measured liquid at the sensor input and output sides are close to the ground.

With a flanged sensor installed in electrically conductive piping, the flanges shall be electrically connected with the piping and the piping put to earth.

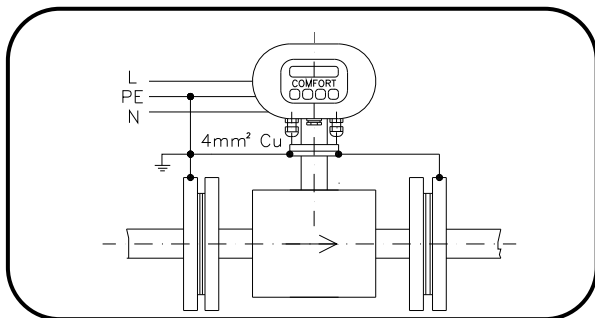

Flange earthing connection

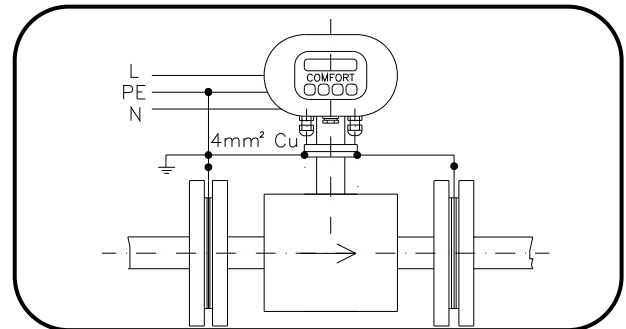

Earthing rings

Should the adjoining piping sections be non-conductive, earthing rings or similar arrangement shall be used to ensure that the electric potential of the measured liquid is put to earth.

With a flangeless sensor, the flanges clamping the sensor shall be electrically connected and the connecting conductor interconnected with the earthing point on the sensor.

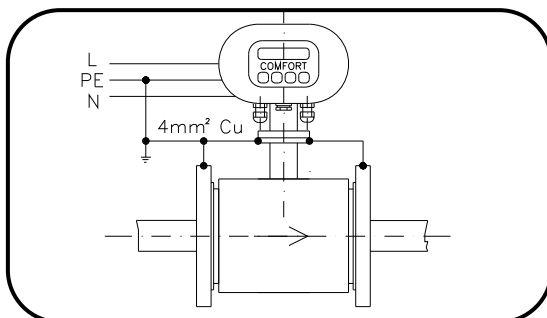

Flangeless sensor

With the distributed meter version, to ensure potential equalisation, it is recommended to connect the flow sensor body with the electronic unit box using a copper conductor of cross-section 4mm^2 .

6. LOW METER INSTALLATION AND OPERATIONAL START

The meter installation work shall be performed in strict observance of the procedures and rules described in this manual.

To prevent undesirable interference, the power cables shall be laid at least 25cm away from all signal cables. The signal cables include the cable connecting the sensor and the associated electronic unit (in the case of a distributed meter version), output signal cables and the cable of the RS 485 communication line. All cables shall be laid outside the thermal insulation layer on the piping (if any). Only shielded conductors shall be used to connect the output signals and the RS 485 line where the shielding shall be connected to the earth potential on the side of the plant control system.

In applications where high levels of electromagnetic field interference at the measuring location can be expected (e.g. in the vicinity of power frequency converters), the distributed meter version should be avoided. In these cases it is also recommended to include a filter in the power supply line to the electronic unit.

Filter specification: The filter is intended to suppress dissemination of the undesirable high frequency disturbances from the power supply cable to the flow meter system. Use any commercial filter of suitable parameters including protection class, and install it as close to the meter as possible. If need be, the filter can be placed in a special protection housing. When installing the filter, observe the applicable safety regulations.

Rated voltage:	250V/50Hz
Rated current:	0.5A and more
Suppression characteristic:	10kHz: 10 to 20dB 10MHz: 40dB

6.1. Sensor Installation

The measurement point chosen for the sensor installation should ensure that the internal part of the sensor is fully flooded with the measured liquid at all times. If the sensor is mounted in vertical position, the only permitted liquid flow direction is upwards. No thermal insulation shall be used on the sensor body.

If the flow meter is to be installed in a pipeline with thermal insulation, the insulation shall be removed at the sensor insulation point.

The internal diameters of the piping, connecting flanges and the sensor tube shall be identical. The flange faces shall be perpendicular to the piping. The input and output piping sections including seals shall be perfectly aligned, with no protruding edges. In the case of a non-conductive piping, use earthing rings on both sides of the sensor.

The arrow on the sensor body indicates the required fluid flow direction (positive flow direction).

Upon loosening the four bolts holding the electronic unit box in position on the sensor body, the box can be rotated through $\pm 180^\circ$. The same system for the box rotation can be used if the box is mounted on a bracket attached to a vertical support plate or wall.

Do not expose the electronic unit box to direct sunlight; in the cases of outdoor installation, use a suitable protection shield.

6.2. Electric Connections of Induction Flow Meter

The terminals for connecting cables can be accessed upon removal of a cover at the rear part of the box housing the electronic unit. The cover is held in position by six socket-head bolts. A schematic diagram of the connections is shown on the rear side of the cover.

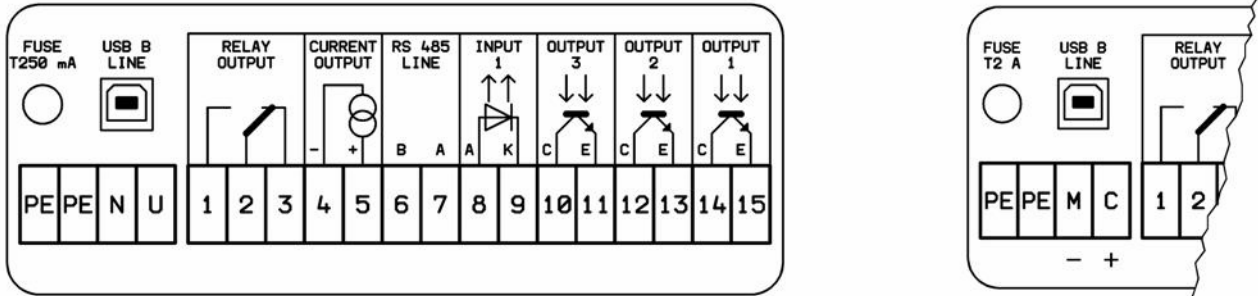

Examples of labels showing power supply (line voltage or 24VDC source) and meter signal interconnection.

6.2.1. Connection to Power Source

Terminal	24V 115V 230V/AC/50 ÷ 60Hz
PE	PE earthing conductor
N	N neutral conductor
U	L phase conductor

Terminal	24VDC
PE	PE earthing conductor
M	M middle conductor
C	L+ +24V

To connect the power source, use a standard cable of three conductors of square section not exceeding 3 x 1.5mm². For ambient temperatures over 122°F, use a cable with rated operating temperature of at least 194°F. The box grommets will only accommodate cables with outer diameter between 4 and 8mm. Use of any other cable would disturb the integrity of the IP 67 box.

The earthing conductor shall be longer than both the phase and neutral conductors. This is a safety requirement as in the case of loosening the cable clamping in the gland, the earthing conductor shall be the last to be disconnected from the terminal (see clause 6.10.2.2. of standard EN 61010-1).

The power supply line shall be protected by an overcurrent circuit breaker. A seal should be applied on the breaker to prevent unauthorised handling. The electronic unit has no independent power switch. The recommended rating of the overcurrent circuit breaker is 4 to 6A.

6.2.2. Output Signal Connections

Terminal	Polarity	Function	Comments
1	Switching contact	Change-over contact	Optocoupler insulated contact 0.3A, 30VDC
2	Central contact	Output relay	
3	Break contact	(optional)	
4	- pole	Current output (optional)	Active output, max. loading (Rz) 1,000Ω. No external power source needed.
5	+ pole		
6	Conductor B (-)	RS 485 (optional)	To be directly connected to communication line
7	Conductor A (+)		
8	Anode (+)	Dosing (optional)	Passive input 5VDC, 10mA
9	Cathode (-)	Binary input 1	
10	Optocoupler collector (+)	Dosing (optional)	Passive output, requires external power source and loading resistor
11	Optocoupler emitter (-)	Binary output 3	
12	Optocoupler collector (+)	Binary output 2	Passive output, requires external power source and loading resistor
13	Optocoupler emitter (-)		
14	Optocoupl. collector (+)	Binary output 1	Passive output, requires external power source and loading resistor
15	Optocoupler emitter (-)		

The output terminals can be connected to co-operating electronic equipment using standard shielded signal cables of external diameter 3 to 6.5mm and conductor cross-section 0.5 to 1.5mm². Shielded conductors shall also be used to connect all output signals and the communication line where the shielding shall be connected to the earth potential on the side of the plant control system.

Upon connecting the conductors to the terminals, tighten the bolts holding the electronic box cover and check the grommet sealing. The unused grommets shall be blinded.

6.3. Connection Between Sensor and Electronic Unit (distributed meter version)

In a compact version of the meter, this connection is internal. With a distributed meter version, the electronic unit shall be connected to the associated sensor by means of a special cable supplied attached on the electronic unit side. On the sensor side, connect the cable wires paying attention to the wire insulation colours and the terminal identification labels.

Special cable UNITRONIC Cy PiDy 3x2x0.25 length up to 50m, temperature up to 158°F:

Brown BN	A
Blue BU	B
White WH	C
Green GN	D
Yellow YE	E
Yellow and green GNYE	Shielding
Pink PK	W2
Gray GY	W1

6.4. Connection Between Sensor and Electronic Unit (distributed meter version, protection class IP 68)

In the IP 68 version of the flow sensor, the terminal box is sealed by cast plastic and the connecting cable is fixed on the sensor side. On the electronic unit side, the cable is provided with a screw-on connector with its mating part mounted on the electronic unit bracket. To prevent unauthorised handling, this connector can be sealed. The hole for the seal wire is provided in the bracket.

6.5. Operational Start

6.5.1. The ECONOMIC version

The induction flow meter of either compact or distributed design must first be fitted mechanically and then the power supply and output terminals be interconnected. Then switch on the supply voltage. Within a short time, the meter will be initialized and its operational conditions stabilised. Information on the fluid flow parameters will start to be communicated from the meter outputs to the co-operating equipment (the plant control system) equipment.

The ECONOMIC version of the meter does not include any keyboard or display unit. The meter configuration is always customized. Changes in the configuration and/or setting can be performed via the USB serial communication line using a computer with the FLOSET 2.0 software.





6.5.2. The COMFORT version



The induction flow meter of either compact or distributed design must first be fitted mechanically and then the power supply and output terminals be interconnected. Then switch on the power supply voltage. For a short while, the meter display will show a welcome message. Then the measured flow rate values will appear on the display.



6.5.3. Operational data

The COMFORT version of the meter includes a two-line alpha-numeric display of 2 x 16 characters with a background illumination. The display illumination function works in a power-saving mode where the illumination is automatically switched off 255 seconds following the last push-button action. On depressing any push-button, the display background illumination is reactivated.

The keyboard includes four push-buttons provided with the following symbols:

1. Push-button , the “roller” push-button, direction downwards
2. Push-button , movement upwards, in the direction of the arrow
3. Push-button , password entry push-button
4. Push-button , referred to as the “Enter” push-button

The meter display makes possible reading of different types of data. To switch to the desired data display mode, use push-buttons  (direction downwards) and  (direction upwards).

To display temporary data, depress push-button . Depress push-button  again to return to the total data display mode.

1. Flow rate

Average flow rate determined from the specified number of sample readings. The value is also used for calculation of other measured quantities.

Flowrate
120.678 gal/m

Display reading: Flow rate

2. Total volume +

The total volume of the fluid passed through the meter sensor in the direction of the arrow on the sensor body since the measurement start, or the temporary volume, i.e. the volume of fluid passed since the last resetting of the temporary volume + data.

Total volume +
1234.567 gal

Temp. volume +
765.432 gal

Display reading: Total volume +

3. Total volume -

The total volume of the fluid passed in the direction against the arrow on the sensor body since the measurement started, or the temporary volume since the last resetting of the temporary volume - data.

Total volume -
123.456 gal

Temp. volume -
65.321 gal

Display reading - Total volume -

4. Total difference

The difference between fluid volumes passed in the positive (+) and negative (-) directions since the measurement start, or temporary difference from the last resetting of the temporary difference data.

Total difference
1111.111 gal

Temp.difference
700.111 gal

Display reading: Total difference

5. Operational time

The length of the time period, in hours and minutes, counted from the first meter start, or the length of the temporary time period measured since the last resetting of the temporary time data.

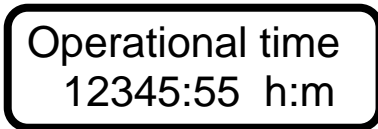

Operational time
12345:55 h:m

Display reading: Operational time

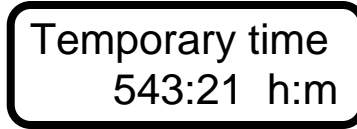

Temporary time
543:21 h:m

Upon switching off the induction flow meter, the data readings under items 2, 3, 4 and 5 are stored at the EEPROM unit and restored upon each new meter start.

6. Percentage flow rate

Flow rate information in the form of a horizontal bar whose length corresponds to the flow rate value in per cent of a selected 100% value (need not necessarily be the same as the maximum flow rate for the given sensor). The figure on the right side offers the digital form of the same information. The minus sign before the figure indicates negative flow data.

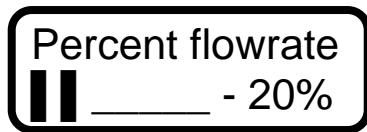

Percent flowrate
|| _____ - 20%

Display reading: Per cent flow rate

7. Last error

Abbreviated text of the last error message.





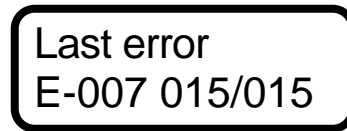

Last error
7:sensor discon.



Last error
E-007 015/015

Display error: Last error

In the case of a meter error, provided the error-indication mode has been enabled, the display will immediately show a message including a short description of the error concerned. Upon depressing push-button , the meter will return to the data display mode, while the abbreviated error message and error code are stored in the "previous errors" register. While an error is indicated, the measurement functions continue undisturbed. In the cases of errors E6 or E7, zero flow rate is indicated throughout the error condition duration.

The user may review earlier error codes and messages up to 255 previous error messages stored in the error register. To access this function, depress push-button  (previous error display). In the data format E-XXX YYY/ZZZ are: XXX the error code, YYY error ordinal number, and ZZZ the total number of error codes stored in the register. To page through the list use push-button . To return to the data display mode, depress push-button . Error register is reset with switching power on.

The error messages are:



- E0:** No error.
- E1:** Error in CRC EEPROM. Incorrect data check sum in the EEPROM unit. This error may occur when the processor, following a power failure, does not manage to store all data in the EEPROM unit.
- E2:** OUT1 (multi-functional output) is in the impulse mode of operation and the memory block storing the unsent impulses overflows.
- E3:** OUT2 (multi-functional output) is in the impulse mode of operation and the memory block storing the unsent impulses overflows.
- E4:** Multifunctional output RELAY is set for impulse output and the memory block storing the unsent impulses overflows.
- E5:** WDOG: the processor reset condition due to the overflow in the timer controlling the length of the programming loop.
- E6:** Not fully flooded piping.
- E7:** Open current loop in the impulse generation circuitry of the meter sensor.
- E8:** Error in +5V power line.
- E9:** Error in +24V power line.
- E10:** Error in -5V power line.
- E11:** Actual flow rate exceeded the selected I_{max} value.
- E12:** Failure in frame receipt confirmation while communicating via a serial line.
- E13:** Error no processed

Error indication mode enabled: error information is displayed and entered into the error register. Some errors result in setting the indicated flow rate at zero.

Error indication mode disabled: the error information is entered into the error register.

8. Dosing

Dosing is visible and functional provided this data display mode has been selected.

The selected fluid volume (dose) will wait for the active initiation signal to be brought to terminals 8-9. As soon as such signal is received, a count towards zero will commence. Upon reaching zero, OUT3 will close. The dosing action can be repeated by depressing push-button . To interrupt dosing, use push-button . To set the required dose, follow the respective procedure in the programming menu.

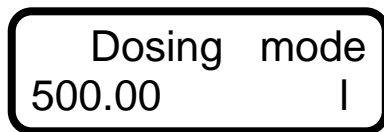











Display reading: Dosing mode

6.5.3.1. Display formats of aggregate values

If the displayed value occupies more than 11 digit places including the decimal point, the calculated value will be displayed alternately with the selected measurement unit.





6.5.3.2. Data reset

The user is not permitted to reset the aggregate data values under items 2, 3, 4 and 5. Resetting is only possible with running (“temporary”) values associated with items 2, 3, 4 and 5 accessible via push-button  (another depression of push-button  will return the display to the total value display mode). When a temporary value is displayed, depress push-button  to discontinue the temporary value mode, and depress push-button  to reset the temporary value. By depressing any of push-buttons    and after that push-button , return to the total value display mode. If you stop the temporary mode and wish not to reset the temporary value, depress any of push-buttons  , whereby the count continues. To return to the total value mode, depress push-button . This procedure will reset the edited temporary value only, the other temporary values will be unaffected.

7. PROGRAMMING



The induction flow meter can be programmed in two ways: using a computer connected to the serial meter interface, or using its own keyboard. The following description concerns the keyboard (push-button) programming procedures.

The keyboard includes four push-buttons provided with the following symbols:

1. Push-button , the “roller” push-button, direction downwards;
2. Push-button , movement to the right in the direction of the arrow, direction upwards;
3. Push-button , password entry push-button, movement upwards in the direction of the arrow, movement back in the menu;
4. Push-button , referred to as the “Enter” push-button (command confirmation).



In any menu, the selected item is on the first line with the first character blinking.

Entry to the programming mode, movement within a menu and data saving

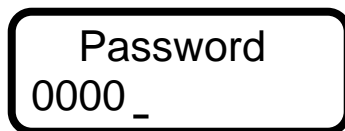

To enter the programming mode, depress push-button  and then . The programming mode is protected against unauthorised action by a password (a four-digit number) that needs be entered before accessing the basic programming menu. Upon delivery from the manufacturing plant, every new meter has a password of 0000.



Display reading: Password

With a new meter, enter password 0000 and confirm by push-button . Provided you have already chosen your own password, enter the same and confirm by depressing push-button . Prior to leaving the programming mode, the password can be changed without any limitation.

Use the push-button  to move the cursor to the right. Upon reaching the extreme right position, the cursor will return to the left side of the line. The cursor is a short horizontal line to be placed under the character we wish to edit/change.

Use the push-button  to change the selected character in the direction upwards, or push-button  in the direction downwards. Upon reaching the last character in the character series available, the first eligible character will reappear.

Upon completing the editing action, confirm your choice of password by push-button . Should you enter an incorrect password, the display will read “Incorrect password Try again” while the program will return to the data display mode.

Password OK
Press any key

Display reading: Confirmation of correct password entry: Password OK. Press any key.

With the display reading “Password OK Press any key”, depress any push-button (preferably \square) to enter the basic programming menu.

The two-line display will always show two of the following basic menu options:

Displayed data
Samples
Analog output
Output functions
Electrode clean
Serial line
Production data
Dose setting
Zero setting
100 percent
Exit

Display reading: The basic menu options

Use push-buttons \square and \downarrow to move upwards and downwards in the menu. As in any meter menu, the selected item is on the first display line with the initial character blinking.

Depress push-button \square to enter a subordinated menu, or to edit a menu item. When in a subordinated menu, depress push-button \uparrow to return to the higher-level menu (the “Escape” function). When in the basic menu, the Escape command will bring forth the possibility to terminate the programming mode via the selection of the “Exit” item of the basic menu.

7.1. Programming of The Basic Menu Items

7.1.1. Displayed data

The “Displayed data” menu allows the operator to choose which parameters are to be displayed. Using push-buttons \downarrow and \square , select parameters from the following list. The Flow Rate display cannot be cancelled.

Menu: Displayed data, depress \square

The two-line display unit will always show two of the items from the following menu. Use push-buttons \downarrow and \square to page upwards and downwards through the menu items.

Flow rate
Total volume +
Total volume -
Total difference
Operational time
Percent flow rate
Last error
Dosing mode

Menu: Displayed data, depress \square / Total volume depress \square

Display line 1 will read "Do not display", line 2 "l/s l". Use push-buttons \uparrow and \downarrow to go up and down in the menu items. If you choose "Do not display", depress \square to return to the "Displayed data" menu. If you wish to display "Total Volume +", select the "Total Volume +" item on the menu, depress push-button \square , skip line 1 (Do not display) and select line 2, "l/s l" (flow-rate unit ... volume unit). Using push-buttons \downarrow (downwards) and \uparrow (upwards), select the desired flow-rate and volume units and confirm the selection by depressing \square . The display line 1 will then show "0" and line 2 "0.0". Using push-buttons \downarrow (downwards) and \uparrow (upwards), select the desired number of decimal positions, confirm the selection by depressing \square and return to the "Displayed Data" menu.

Comment:

The measurement unit selected for "Flow Rate" is automatically set for all other flow-rate quantities referred to in the Programming menu.

The measurement unit selected for "Total Volume +" is automatically set for all other flow-volume quantities in the Programming menu.

The measurement units for the "Total Volume -" and "Total Difference" quantities can be selected as need be, and their selection will not affect any other measured quantities to be set within the Programming menu.

Table of flow-rate and volume units

l/s	l
l/min	l
l/h	l
m ³ /s	m ³
m ³ /min....	m ³
m ³ /h	m ³
GPS	G
GPM	G
GPH	G

Table of decimal positions

0
0.0
0.00
0.000
0.0000
0.00000
0.000000

User-specified units:

When defining a user-specific unit, it is necessary to enter a conversion constant (a multiple of the standard flow-rate or volume units – "l/s" or "l", then depress \square , define the unit name (six characters), depress \square , define number of decimal positions, depress \square and return to the "Displayed Data" menu.

Example: the desired flow rate unit is US barrel per second; the conversion constant is 0.006283811; unit name bl/s; number of decimal positions 0.000.

The same procedures apply to parameter setting with Flow Rate, Total Volume +, Total Volume - and Total Difference.

While setting the parameters of Operational Time, Per Cent Flow Rate, Last Error and Dosing, the options to select from are only "Display" and "Do Not Display".

To leave the "Displayed Data" mode and return to the basic programming menu, depress push-button \square .

7.1.2. Samples

The number of samples N , on the basis of which the average flow rate value is determined, can be set within the range of 1 to 255. While the measurement frequency is 6.25Hz (or 3.125, 1 or 0.5Hz), fast (step) changes in the flow rate will be smoothed within the interval of 0.08 to 20.40s (0.16 to 40.80s, 0.5 to 127.5s or 1 to 255s). The averaging feature is useful in the cases where the flow through the meter sensor is unstable, the fluid is turbulent or where there are air bubbles trapped in the fluid flow.

The averaging function helps suppress fast changes in the fluid flow rate. Average flow rate as measured and displayed is the parameter used to calculate other meter outputs.

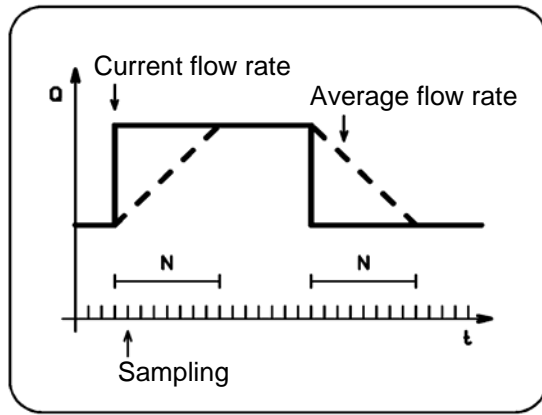

Suppression of step changes in flow rate

Menu: Number of samples, depress \square

The display will read "Number of samples xxx". Replace xxx by a number from the range of 1 to 255 (usually 25 is chosen). Move the cursor using push-button \square and increase/decrease this number using \uparrow or \downarrow , respectively. Confirm the selection by push-button \square . The display will then read "Value entered Press any key". Press \square or any other push-button. This action will take you back to the basic menu.

7.1.3. Analog output

Setting options:

Connected to terminals 4 and 5 is a programmable current output. It is an active current output, insulated from other meter parts. The maximum output load is 1,000 Ω . Depending on the fluid-flow characteristics, the output can be used in four different modes of operation (see the graphs below) and in two selectable measurement ranges.

The two-line display unit will always show two of the items from the following menu. Use push-buttons \downarrow and \uparrow to page downwards and upwards through the menu items.

Menu: Analog output, depress \square

0...+Q Output
0...-Q Output
Q Output
-Q...+Q Output
Fixed current 0...20

In all operational modes excepting the "Fixed Current" mode, the current output range can be user defined.

Menu: Analog output, depress \square / Output 0...+Q, depress \square

Output 0...20mA
Output 4...20mA

Selection of current output

Menu: Analog output, depress \square / Output 0...+Q, depress \square / Output 0...20mA, depress \square / Flow rate for I_{max}

The current output setting consists of defining flow rate Q_{max} corresponding to I_{max} . Move the cursor using push-button \square , and increase/decrease the Q_{max} value using push-buttons \uparrow and \downarrow . Select the desired Q_{max} and confirm the setting by depressing \square . The display will then read "Value Entered Press Any Key". Press any key, preferably the \square push-button. This action will take you back to the main programming menu, item "Analog output".

In the "Fixed current" mode, the output current can be set within the range of 0 to 20mA. This mode is used for meter servicing purposes.

Menu: Analog output, depress \square / Fixed current 0...20, depress \square / Fixed current 0...20mA

Move the cursor using push-button \square , and increase/decrease the current value using push-buttons \uparrow and \downarrow . Select the desired current value and confirm the setting by depressing \square . The display will then read "Value Entered Press Any Key". Press any key, preferably \square . This action will take you back to the main menu, item "Analog Output". At the same time, the defined current will start to flow through the output circuit.

The following graphs show the relationships between current I and flow rate Q for various operational modes:

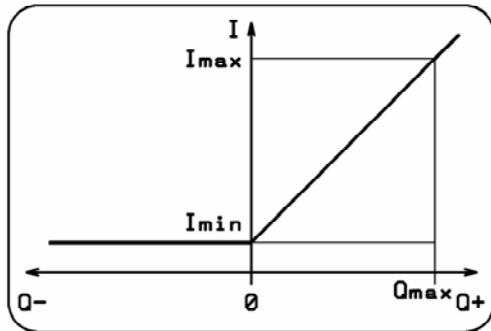

Output current for 0 ...+Q

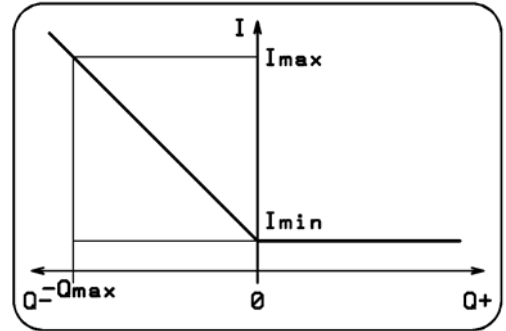

Output current for 0 ...-Q

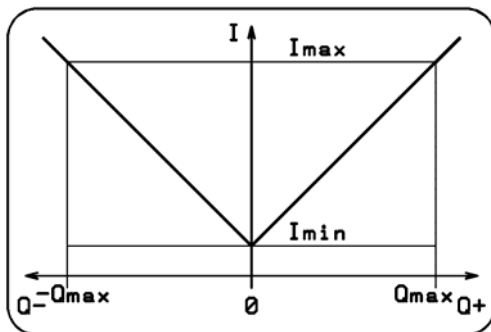

Output current for $|Q|$

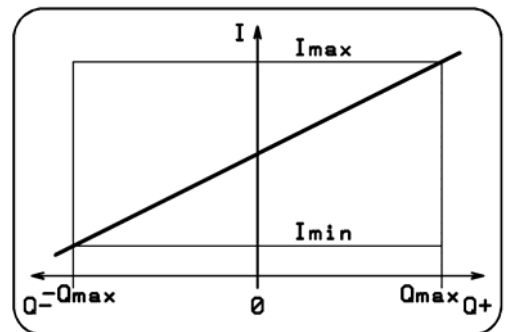

Output current for -Q ...+Q

Examples of analog output interconnections

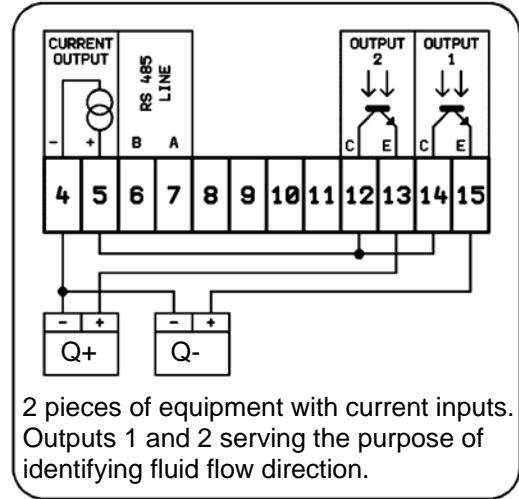
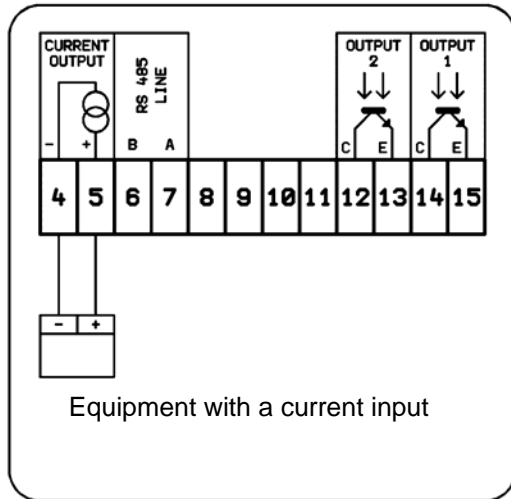

Multifunctional outputs programmed to identify the fluid flow direction and to negate the flow direction, will divide the analog output operated in the “Absolute Flow-Rate Value” mode into two outputs, one for each flow direction.

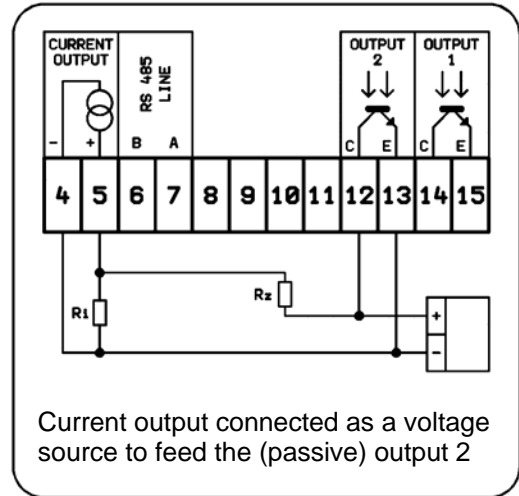
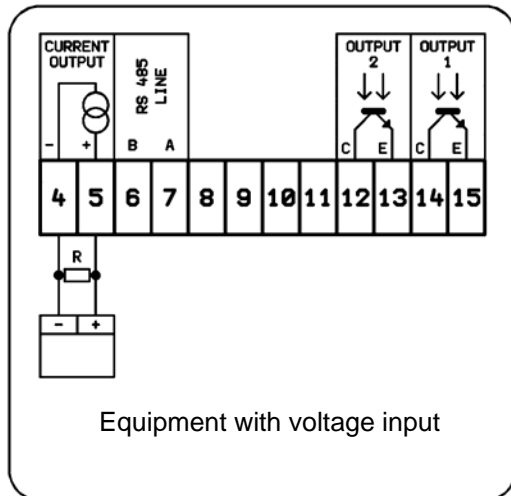

The output voltage for the co-operating equipment is defined as the voltage drop on resistor R. It holds: $U = I R$.

For the voltage range of 0...10V, select $R = 500\Omega$ and the analog current output range 0...20mA. Resistor R shall be placed as close to the input terminals of the co-operating (controlled) equipment as possible. The maximum voltage (voltage drop on the resistor) is 10V. The input impedance of the controlled equipment shall be at least 100 times higher than that of resistor R.

The interconnection of the current output as an auxiliary power source for the binary outputs is shown in the above picture. This arrangement assumes that the current output is not used for the purposes of flow rate indicator. Here the current output needs be set in the “Fixed Current” mode of operation. The voltage drop on resistor R_i is used as supply voltage for the binary output (via resistor R_z). The input impedance of the associated equipment shall be at least 10 times higher than that of resistor R_z , while R_z shall be at least 10 times higher than R_i . It holds: $R_i < R_z < \text{input impedance of the co-operating equipment}$.

Analog output specifications

The analog output signal is controlled by a 12-bit DA converter. The operational range 0 to 20mA is divided into 4,096 steps. One step (1LSB) therefore corresponds to about 0.005mA (0.025% of 20mA). This resolution applies to all output ranges. The current range 4 ... 20mA is software-defined with the converter steps reduced accordingly. The maximum voltage at the current output is 20V; the maximum resistance of the current loop therefore is 1,000Ω.

7.1.4. Output functions

The configuration of the induction flow meter includes two binary multifunctional outputs, electrically isolated by means of optocouplers. The output transistors of the optocouplers are accessible via terminals 12-13 and 14-15. These are passive outputs that need external power source. Alternatively they can be powered by the analog output in the fixed-current mode as described above. The binary outputs can be loaded and repeatedly switch on and off currents 1 to 50mA.



Default settings: Output 1: frequency output, Output 2: impulse output.



Flow meter can be equipped with an output relay, designated in the menu as item "Relay Functions". Electrically isolated relay contacts are accessible via terminals 1-2-3. For impulse output, both the impulse width and the minimum gap length are set at 0.5s. To ensure correct functioning of the impulse function, it is necessary to set the output impulse constant (the fluid volume per impulse) so that the memory block of unspent impulses would never overflow.



Menu: Output functions, depress 

The display will offer the following selection:

OUT1 function
OUT2 function
RELAY function

The two-line display unit will always show two of the items from the above menu. Use push-buttons  and  to page downwards and upwards through the menu items.

Menu: Output functions, depress  / Output 1 function, depress 

The two-line display unit will always show two of the items from the respective menu. Use push-buttons  and  to page downwards and upwards through the menu items.

The output functions available are shown in the following table:

Permanently open Perm. closed
Q impulses Q+ impulses Q- impulses
Q+ frequency Q- frequency Q frequency Fixed frequency
Negative flow Non-neg. flow
Error occurred No error occurred
Q>Qlim. Q<Qlim. Q >Qlim. Q <Qlim.
Cleaning Not cleaning

} **Frequency can not be used for relay output**

Permanently closed (open)

These modes are only used for servicing purposes.

Menu: Output functions, depress  / Output 1 (2) function, depress  / Permanently closed (open), depress 

This will return the display to the menu item "Output 1 Function" or "Output 2 Function".
To return to the basic programming menu, depress push-button .

Impulse outputs

In any of the impulse modes, an impulse will be generated as soon as a defined (preset) fluid volume passes through the meter sensor. The impulse mode requires specification of the following three parameters: impulse width "t_U", minimum time gap between two successive impulses "t_D" and fluid volume per impulse "V".

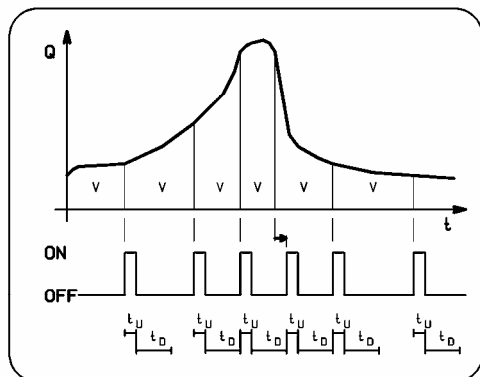

Impulse generation principle

It holds: maximum impulse frequency = $1 / (t_U + t_D)$

This mode provides for integration of the flow rate values in time. As soon as a preset fluid volume V passes through the meter, an impulse of width t_I is generated. After each impulse, a gap of at least t_D follows. If, after elapsing of the t_D period, fluid volume V has not yet passed through the sensor, the output remains inactive. If the volume passed is equal to or greater than V , another impulse plus gap are immediately generated. Should the preset volume V pass before the end of the previous impulse, the non-generated impulse will be stored in an accumulator with the capacity of 255 impulses. Should the impulse accumulator overflow, an error message will be generated. To ensure correct functioning of the meter impulse function, it is necessary to set the impulse output parameters so that the expected impulse frequency shall correspond to the impulse width and gap length selected.

The volume per impulse parameter can be set within the range of 0.001 to 1,000,000 litres. The impulse width and gap length can be set at 10 to 2,550ms in steps of 10ms. The setting procedure consists of selecting numbers from 1 to 255 on the meter display. Multiplied by 10, the figure shows the impulse width or gap length in milliseconds.

From the above it follows that the maximum impulse frequency is 50 per sec.

Regarding the flow rate conditions (see below), impulses can be generated in three different modes. During the t_I periods, the output is closed.

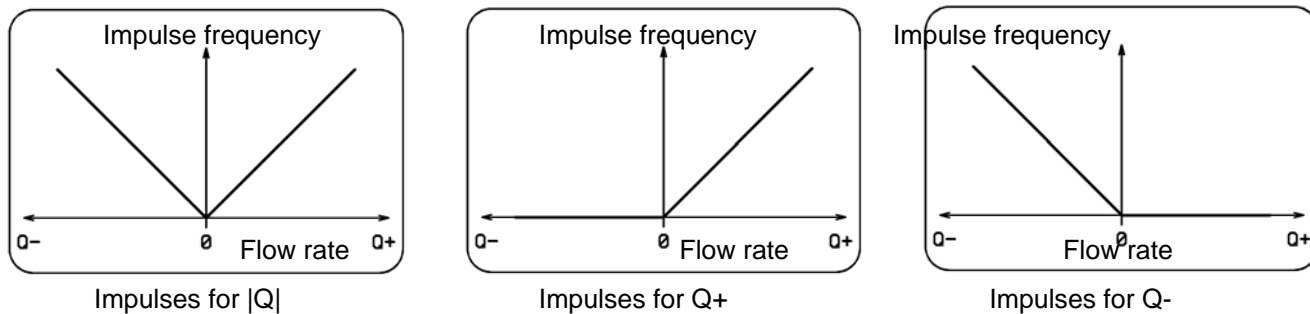

Menu: Output functions, depress \square / Output 1 (2) function, depress \square / Impulses for $|Q|$, depress \square

The display will read "Impulse Width [1] xxx". Move the cursor using push-button \square , and increase/decrease the values at various "x" positions using push-buttons \uparrow or \downarrow , respectively. Replace xxx by a figure which, when multiplied by 10, will give the impulse width in ms. Depress \square . The display will read "Value Entered Press Any Key". Press any key, preferably \square . The display will then show the message "Gap Length [1] xxx". Move the cursor using push-button \square , and increase/decrease the values using push-buttons \uparrow or \downarrow , respectively. Replace xxx by a figure which, when multiplied by 10, will give the gap length in ms. Depress \square . The display will read "Value Entered Press Any Key". Press any key, preferably \square . The display will then show the message "Volume Per Impulse [1] xxxxxx". Move the cursor using push-button \square , and increase/decrease the "x" values using push-buttons \uparrow or \downarrow , respectively. Replace xxxxxx by a figure equal to the desired fluid volume per impulse. This figure is elsewhere referred to as the impulse constant or impulse number. Depress \square . The display will read "Value Entered Press Any Key". Press any key, preferably \square . This will return the display to the menu items "Output 1 Function" or Output 2 Function". To return to the basic menu, depress push-button \uparrow .

Impulse number selection for NORMAG

Diameter	Dimension	Qmax	Imp. number	Qmax	Coefficient	Imp. number	Qmax
Inches	DN	l/m	l/imp	gallon/m		gallon/imp	gallon/m
	10	0.777	1	0.205261	3.785412	1	12.32
1/2"	15	1.8	1	0.475509	3.785412	1	28
3/4"	20	3.33	1	0.879693	3.785412	1	53
1"	25	5	1	1.320860	3.785412	1	79
1 1/4"	32	8.33	5	2.200553	3.785412	1	132
1 1/2"	40	12.5	5	3.302150	3.785412	1	198
2"	50	20	5	5.283441	18.92706	5	317
2 1/2"	65	33.33	10	8.804854	18.92706	5	528
3"	80	50	10	13.20860	18.92706	5	793
4"	100	77.77	50	20.54466	18.92706	5	1233
5"	125	119.44	50	31.55271	37.85412	10	1893
6"	150	180.55	50	47.69626	37.85412	10	2862
8"	200	319.4	100	84.37655	189.2706	50	5063
10"	250	500	100	132.0860	189.2706	50	7925
12"	300	700	500	184.9204	189.2706	50	11095
14"	350	972	500	256.7752	378.5412	100	15406
16"	400	1250	500	330.2150	378.5412	100	19813
20"	500	2000	500	528.3441	1892.706	500	31700
24"	600	2778	1000	733.8699	1892.706	500	44032
28"	700	3889	1000	1027.365	1892.706	500	61631
32"	800	5000	1000	1320.860	1892.706	500	79251
36"	900	6389	5000	1687.795	1892.706	500	101268
40"	1000	7778	5000	2054.730	1892.706	500	123284
48"	1200	11111	5000	2935.216	3785.412	1000	176113

1 US gallon = 3.785412 l
 Impulse width = 100ms
 Minimum gap length = 100ms
 f <= 5Hz

0.264172037 gall = 1 l
 15.85032224 gall/min = 60 l/min

Uniform output impulses

With series-5 meters (including boards FNA5, FNP5, FNS5 and FNZ5), the user may select the so-called uniform output impulses. These can only be set at the OUT2 output. The standard OUT2 setting on board FNA5 is facilitated by jumper W1 1-2. To set uniform output impulses, remove jumper W1 1-2 and install jumper W1 2-3. Further setting is done by means of the meter keyboard and display.

To set the uniform output impulse mode:

1. Enter the programming menu, select "Production Data" and check the sensor size – e.g. DN40. Return to the basic menu.
2. Select "Output Functions", depress Enter. Select "Output 2 Function", depress Enter. Select "Frequency for Q+" (or Frequency for Q- or "Frequency for |Q|"), depress Enter. Set the value of flow rate per 1 kHz with respect to the sensor dimension. In our case, for DN40, Qmax is 12.5 l/s (see the table below). Return to the basic menu.
3. Select "Production Data", depress Enter. Select "Base Frequency", depress Enter. Enter the value shown in the table. In the case of DN40, the base-frequency value is 8,192. Return to the basic menu and leave the programming menu by selecting "Exit".
4. Install jumper W2 3-4 on analog board FNA5 (see the table). The position of jumper W2 determines the output voltage-divider parameters.
5. This is all you need to do to set uniform output impulses.

Comment: If the actual flow-rate unit is other than litres per second (l/s), the value of 12.5 l/s needs be recalculated. For example, if the actual unit is m³/h, multiply 12.5 by 3.6 = 45 m³/h; enter this value as the "Flow Rate Per 1 kHz" parameter.

Uniform output impulse setting table

Calorimeter impulse constant [litres per impulse]	Flow sensor DN	Qmax [l/s]	Output frequency [Hz]	Base frequency [Hz]	Jumper position on board FNA5
100	15	1,8	0,018	4718,592	W2 5-6
100	20	3,33	0,0333	8729,395	W2 5-6
100	25	5	0,05	3276,8	W2 3-4
100	32	8,33	0,0833	5459,1488	W2 3-4
100	40	12,5	0,125	8192	W2 3-4
100	50	20	0,2	1638,4	W2 1-2
100	65	33,33	0,3333	2730,394	W2 1-2
100	80	50	0,5	4096	W2 1-2
100	100	77,77	0,7777	6370,918	W2 1-2
1000	125	119,44	0,11944	7827,6198	W2 3-4
1000	150	180,55	0,18055	1479,066	W2 1-2
1000	200	319,4	0,3194	2616,525	W2 1-2
1000	250	500	0,5	4096	W2 1-2
1000	300	700	0,7	5734,4	W2 1-2
1000	350	972	0,972	7962,624	W2 1-2

Frequency outputs

In the frequency modes, the output signals will be impulses of impulse-to-gap ratio 1:1. The frequency range available is from 1Hz to 10kHz.

Comment: The electronic unit of the meter includes only one frequency generator. It is therefore impossible to select different frequencies for each output, or combine the fixed-frequency mode at one output with frequency related to flow rate mode at the other output. On the other hand, the operator may select the frequency related to flow rate mode in the positive direction at one output with that in the negative direction at the other output, with the same frequency-to-flow-rate ratios.

Regarding the flow rate conditions, the frequency outputs can be operated in three different modes (see below).

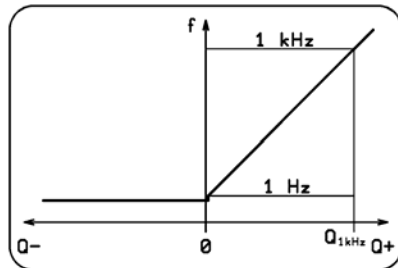

Frequency for Q+

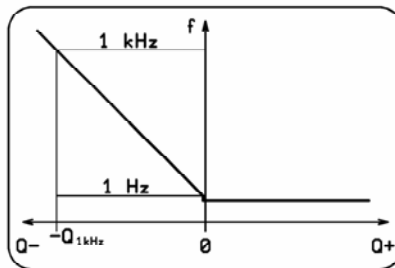

Frequency for Q-

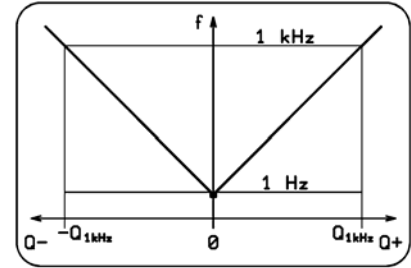

Frequency for |Q|

Menu: Output functions, depress \square / Output 1 (2) function, depress \square / Frequency for Q+, depress \square

The display will read "Flow Rate Per 1kHz xxxx". Move the cursor using push-button \square , and increase/decrease the values at various "x" positions using push-buttons \uparrow or \downarrow , respectively. Replace xxxx by a figure representing the maximum flow rate. Depress \square . The display will read "Value Entered Press Any Key". Press any key, preferably \square . This will return the display to the menu items "Output 1 Function" or "Output 2 Function".

The fixed-frequency mode is used for servicing purposes only. The required frequency is set in Hz within the range of 1 to 10,000 in steps of 1Hz.

Menu: Output functions, depress \square / Output 1 (2) function, depress \square / Fixed frequency, depress \square

The display will read "Fixed Frequency xxxxx". Move the cursor using push-button \square , and increase/decrease the "x" values using push-buttons \uparrow or \downarrow , respectively. Replace xxxxx by a figure equal to the desired frequency in Hz. Depress \square . The display will read "Value Entered Press Any Key". Press any key, preferably \square . This action will return the display to the menu items "Output 1 Function" or "Output 2 Function". To return to the basic menu, depress push-button \uparrow .

Negative (non-negative) flow direction

This mode is used to identify the fluid flow direction. In the case of negative flow direction, the output is closed (open).

Menu: Output functions, depress \square / Output 1 (2) function, depress \square / Negative (Non-negative) flow direction, depress \square .

The display will return to the menu items "Output 1 Function" or "Output 2 Function". To return to the basic programming menu, depress push-button \uparrow .

Error (no error) condition

In the case of a meter error, the output will close (open) and stay so as long as the error condition exists.

Menu: Output functions, depress \square / Output 1 (2) function, depress \square / Error (No error) condition, press \square

The display will return to the menu items "Output 1 Function" or "Output 2 Function".

To return to the basic menu, depress push-button \square .

Exceeding (dropping below) the limit values of flow rate

In the cases of exceeding (dropping below) the preset flow-rate limit values, the output will close (open). Upon return within the normal operating range, the output will open (close) again with a preset hysteresis. Regarding the flow rate conditions, there are four different modes of operation:

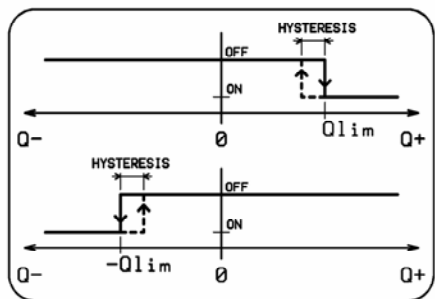

$Q > Q \text{ lim.}$

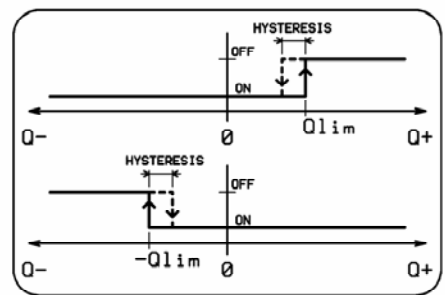

$Q < Q \text{ lim.}$

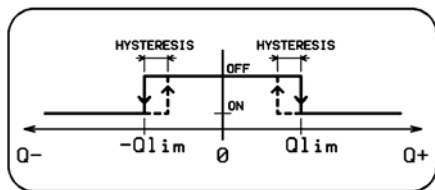

$|Q| > Q \text{ lim.}$

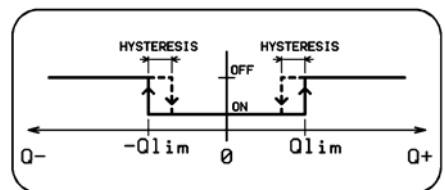

$|Q| < Q \text{ lim.}$

Menu: Output functions, depress \square / Output 1 (2) function, depress \square / $Q > Q \text{ lim.}$, depress \square

The display will read "Flow Rate Limit [1] xxxxx". Move the cursor using push-button \square , and increase/decrease the values at various "x" positions using push-buttons \square or \square , respectively. Replace xxxxx by a figure equal to the flow rate which, when exceeded, should cause the output to close. Depress \square . The display will read "Value Entered Press Any Key". Press any key, preferably \square . The display will then show the message "Hysteresis [1] xxxx". Move the cursor using push-button \square , and increase/decrease the "x" values using push-buttons \square or \square , respectively. Replace xxxx by a figure representing hysteresis, between the closing and opening output functions. Depress \square . The display will read "Value Entered Press Any Key". Press any key, preferably \square . The display will return to the menu items "Output 1 Function" or "Output 2 Function".

To return to the basic menu, depress push-button \square .

Electrode cleaning in progress (No cleaning)

While the electrode cleaning process is in progress, the output is closed (open).

Menu: Output functions, depress \square / Output 1 (2) function, depress \square / Cleaning in progress (No cleaning), depress \square

The display will return to the menu items "Output 1 Function" or "Output 2 Function".

To return to the basic menu, depress push-button \square .

7.1.5. Electrode cleaning



During the meter operation, non-conducting substances may accumulate in the form of a layer on the sensor electrodes. This increases the contact resistance between the electrode and the measured fluid and results in decreased measurement accuracy. The FN 20XX flow meter offers a sensor electrode cleaning function without sensor dismantling. The cleaning method is based on the electro-chemical phenomenon where the electrodes are connected to an AC voltage source causing the accumulated layer to dissolve in the measured fluid. It is recommended that the cleaning process be repeated in regular intervals.

The cleaning cycle lasts 1 minute. Measurements are discontinued during the cleaning action while the immediately preceding flow conditions are being simulated. The cleaning action can be indicated using the multifunctional outputs. While the cleaning process is in progress, the message "Cleaning Electrodes" can be seen on the top display line. The bottom line shows the last value of the selected measured quantity. As soon as the cleaning action is over, the meter resumes normal measurements.

There are several ways of initiating the electrode cleaning cycle:

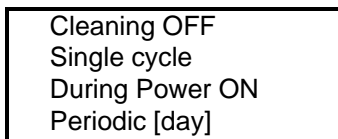
Menu: Electrode cleaning, depress 







The two-line display unit will always show only two of the four menu items. Use push-buttons  and  to page downwards and upwards through the menu items. Select the desired item and depress . The display will return to the basic menu, item "Electrode Cleaning".

Upon selecting the "Single cycle" option, the cleaning process will immediately start. On completion of the cleaning cycle, the meter will return to the "Cleaning OFF" status.

The selection of "During Power ON" implies that a cleaning process will be initiated wherever line voltage is switched on. In the "Periodic [Day]" mode of operation, cleaning processes will be initiated automatically in regular intervals to be chosen by the user from the range 1 to 255 days. The time counting process will always start upon setting a new cleaning period.

Comment: When using a supply voltage source 24V AC/DC, the electrode cleaning function is inoperative.

Menu: Electrode cleaning, depress  / Periodic [day], depress 

The display will read "Cleaning [Day] xxx". Move the cursor using push-button , and increase/decrease the "x" values using push-buttons  or , respectively. Replace xxx by a number from 1 to 255 (days). Depress . The display will read "Value Entered Press Any Key". Press any key, preferably . This action will return the display to the basic programming menu, item "Electrode Cleaning".

7.1.6. Serial line

The meter is provided with a serial communication interface intended for servicing purposes. In the standard configuration, the USB port is implemented. Electrically insulated port RS 485 is included on special request.

Serial port USB

This port is accessible through USB type B connector. Interconnection to the computer is facilitated by means of a cable provided with USB type A connector at one end and USB type B connector at the other end.

The USB port is not insulated from the other meter circuits; it is primarily intended for servicing purposes. Permanent operational use is not recommended.

Serial port RS 485

The RS 485 port is optional accessory of the induction meter. It is electrically insulated from the other meter circuitry and allows for interconnection of up to 31 flow meters to a common communication network. The maximum length of the connecting two-wire twisted cable is 1,200m. If repeaters are used, the number of meter stations and cable length can further be increased. The cable wires are to be connected to terminals 6 and 7.

The flow meter found at the end of the communication network shall be provided with jumper W1 with a terminal resistor 120 R. Jumper W1 is located on the terminal board FNS1 between the terminal strip and lightning arrester

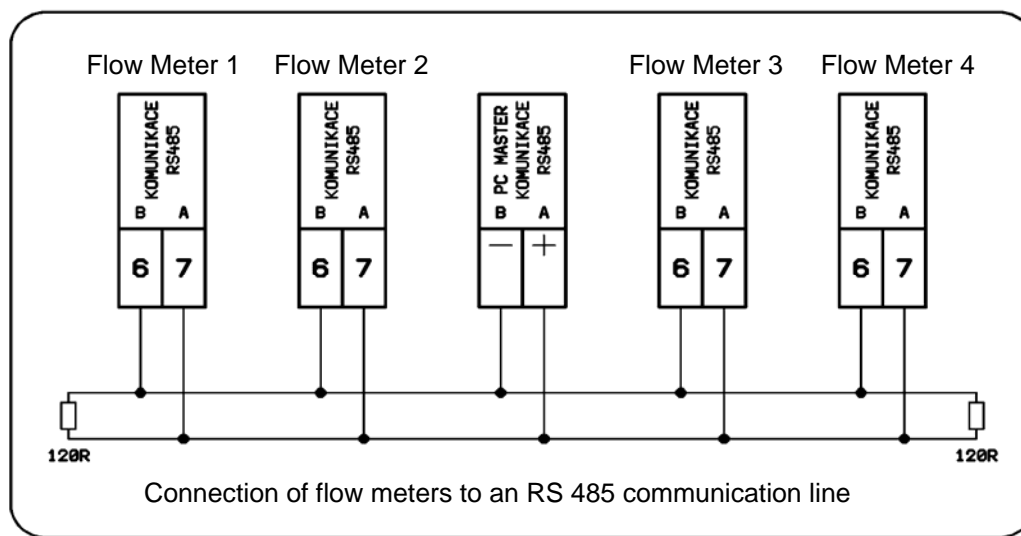

Communication

Communication consists of transmission of individual data packets. To ensure correct function of a communication network, each station must have a different address. On delivery, all induction flow meters will have the following setting of communication parameters: Address 1, Group 1, Speed 9600Bd, Parity SL. Communication uses the FLOSET 2.0 program package.

The communication protocol is not included in this brochure; it can be obtained from the meter manufacturer on request.

Menu: Serial line, depress



- | |
|-----------|
| Address |
| Group |
| Baud rate |
| Parity |



The two-line display will always show two of the menu items. To page through the menu, use push buttons (direction upwards) and (downwards). Select the desired item and depress .

Menu: Serial line, depress / Address, depress

The display will read “Address xxx”. Replace “xxx” by a number from 1 to 255, being the meter address. Depress . The display will show the message “Value Entered Press Any Key”. Press any key, preferably . This command will take you back to the Serial Line menu.



Menu: Serial line, depress  / Group, depress 

The display will read "Group xxx". Replace "xxx" by a number from 1 to 255, being the designation of a group of induction meters. Depress . The display will show the message "Value Entered Press Any Key" Press any key, preferably . This command will take you back to the Serial Line menu.

Menu: Serial line, depress  / Baud rate, depress 



All equipment connected to a particular communication line branch shall use the same communication speed. There are six optional selections of speed:

1200Bd
2400Bd
4800Bd
9600Bd
19200Bd
38400Bd

The two-line display will always show two of the menu items. To page through the menu, use push buttons  (direction upwards) and  (downwards). Select the desired item and depress . This action will bring the display to the Serial Line menu.

Menu: Serial line, depress  / Parity, depress 

Parity --
Parity SL
Parity SS
Parity LS
Parity LL

The two-line display will always show two of the menu items. To page through the menu, use push buttons  (direction upwards) and  (downwards). Select the desired item and depress . This action will bring the Serial Line menu on the display.



To return to the basic programming menu, item Serial Line, depress push-button .



7.1.7. Production data

The first three menu items, i.e. Production Data, Series Number and Software, give basic information on the induction flow meter concerned and as such cannot be edited. The remaining items, i.e. Sensor Constants, Excitation Frequency, Suppressed Flow Rate, Language, Sensor Number, Sensor DN, Errors, Dose Correction, Flow Direction and Base Frequency can be changed by the user unless the flow meter is certified and used as a commercial meter; in such cases the sensor constants, excitation frequency and suppressed flow rate are protected against unauthorised modification.



Menu: Production data, depress 

Production date
Serial number
Software
Sensor constants
Excitation freq.
Suppressed flow
Language
Sensor number
Sensor DN
Errors
Dose correction
Flow direction
Base frequency

The two-line display will always show two selected menu items. To page through the menu items, depress repeatedly push-buttons  (direction downwards) and  (upwards). To select a particular menu item, depress .

Menu: Production data, depress  / Production date, depress 

The display will read "Production Date dd mm yyyy". This information cannot be edited. To return to the Production data menu, depress any push-button, for example . The menu will reappear on the display.

Menu: Production data, depress  / Serial number, depress 







The display will read "Serial Number xxxxxx". This information cannot be edited. To return to the Production data menu, depress any push-button, for example . The menu will reappear on the display.



Menu: Production data, depress  / Software, depress 



The display will read "Software v.xxxxx/xx". This information cannot be edited. To return to the Production data menu, depress any push-button, for example . The menu will reappear on the display.

Menu: Production data, depress  / Sensor constants, depress 

Constant 1
Constant 2



To page through the menu items, use push-buttons  (direction downwards) and  (upwards). Select the desired item and depress . The constant value will appear on the display. Should you wish to change this value, use push-button  to place the cursor under the selected figure and increase/decrease the same using push-buttons  and , respectively. The sensor constants shall be set at the values given on the sensor rating plate. Unless this is not the case, the flow meter calibration is incorrect.



Menu: Production data, depress  / Sensor constants, depress  / Constant 1, depress 

The display will read "Sensor Constant 1 xxxxxxxx". The value was set during the meter calibration at the manufacturing plant and it should not be changed. Depress . The display will read "Value Entered Press Any Key". Press any key, preferably . This command will cause the menu Constant 1 / Constant 2 to reappear on the display. The same procedure applies to setting the value of Constant 2. To return to the Production data menu, depress push-button .



Menu: Production data, depress  / Excitation frequency, depress 





1 – 6.25 Hz
2 – 3.125 Hz
3 – 1.0 Hz
4 – 0.5 Hz

To page through the menu items, use push-buttons  (direction downwards) and  (upwards). Select the desired frequency and depress .



Menu: Production data, depress  / Excitation frequency, depress  / 2 – 3.125 Hz, depress 



The Manufacturing data menu will reappear on the display with the item “Excitation Frequency” on the first line.





Menu: Production data, depress  / Suppressed flow, depress 

The display will read “Suppressed Flow xxxxx”. This parameter is usually set at 0.5% Qmax and may be increased in cases where it can be demonstrated that while no fluid flows through the meter sensor, the meter indicates a non-zero flow rate. Using push-button  move the cursor to the desired position and increase/decrease the selected figure by push-buttons  and , respectively. Replace xxxx by a number equal to the desired value of suppressed flow rate. Depress . The display will read “Value Entered Press Any Key”. Press any key, preferably . The Production Data menu will reappear on the display with the item “Suppressed Flow Rate” selected.





Menu: Production data, depress  / Language, depress 

The display will read “[CZ] Czech / [EN] English”. To page through the menu items, use push-buttons  (direction downwards) and  (upwards). Select the desired language and depress . The Production Data menu will appear on the display with the Language option on the first line.







Menu: Production data, depress  / Sensor number, depress 

The display will read “Sensor Number”. Using push-button  move the cursor to the desired digital position and increase/decrease the selected figure by push-buttons  and , respectively. Enter the sensor production series number (maximum 10 digits). Depress . The display will read “Value Entered Press Any Key”. Press any key, preferably . The Production data menu will reappear on the display with the Sensor Number item selected.

Menu: Production data, depress  / Sensor DN, depress 

The display will read “Sensor DN”. Using push-button  move the cursor to the desired position and increase/decrease the selected figure by push-buttons  and , respectively. Enter the sensor dimension (maximum 10 digits). Depress . The display will read “Value Entered Press Any Key”. Depress . The Production Data menu will reappear on the display with the Sensor DN item selected.

Menu: Production data, depress  / Errors, depress 

The display will read „1: Error EEPROM, 2: Overflow OUT1“. Scrolling in menu is possible using push-buttons  (down) and  (up). Scroll to desired error and depress . Display will read „Active, Non-Active“. With buttons  and  set desired error feature and depress . Then you can continue with setting of another error. When finished, depress  and return to item "Errors".

Menu: Production data, depress \square , Dose correction, depress \square

The display will read "Dose Correction xxxxx". The value specified here will be added or subtracted from the earlier specified dose size. Move the cursor by repeated actuation of push-button \square , and set the desired value by push-buttons \uparrow and \downarrow (increase/decrease). The five "x" should be replaced by a figure representing the dose correction in the given volume units. Confirm your selection by depressing \square . The display will read "Value Entered Press Any Key". Depress \square . This takes you back to the Production Data menu, item "Dose Correction".

Menu: Production data, depress \square / Flow direction, depress \square

The first display line will show "A \rightarrow B", the second line "A \leftrightarrow B". The first line applies. Select the correct information by push-button \square , then depress \square . The display will read "Value Entered Press Any Key". Depress \square . The Production Data menu will appear on the display with the "Flow Direction" item selected.

Menu: Production data, depress \square / Base frequency, depress \square

The display will read "Base Frequency LXXX". Move the cursor by repeated depressing of push-button \square , and set the desired value by push-buttons \uparrow and \downarrow (increase/decrease). The X-es should be replaced by a figure equal to the base frequency in Hz specified in the table shown in section 7.1.4. Then depress \square . The display will read "Value Entered Press Any Key". Depress \square . This takes you back to the Production Data menu, item "Base frequency".

To return to the basic menu, item "Production data", depress push-button \uparrow .

7.1.8. Dose setting

The dosing mode is operational provided the Display item is selected from the "Displayed Data" menu. The dosing mode allows for measurement of the preset fluid volume (dose). The external initiation command shall be brought to the input of optocoupler IN1. As soon as the preset dose has passed through the meter probe, the output optocoupler (OUT3) will close. The dosing process will be repeated with every new external initiation signal brought to the input of optocoupler IN1. Depress push-button \square to discontinue the dosing process currently in progress. Following that, the next dosing process can be initiated at any time.

Menu: Dose setting, depress \square

The display will read "Dose Size xxxxx". Using push-button \square move the cursor to the desired decimal position and increase/decrease the selected figure by push-buttons \uparrow and \downarrow , respectively. Replace xxx by a number equal to the dose size. Depress \square . The display will read "Value Entered Press Any Key". Press any key, preferably \square . The basic programming menu will reappear on the display with the "Dose Setting" item selected.

7.1.9. Zero setting

The zero-setting function is useful in the cases where the actual flow rate is very small (e.g. due to leakage in closed valves) and for all practical purposes equal to zero. This function can only be used with meters in a single flow-direction application. Should you open the zero-setting programming mode by mistake (not wishing to change the zero setting), proceed using the Cancel-Zero setting sequence of commands.

Menu: Zero setting, depress \square

The display will read "Setting Completed" and show the flow rate as indicated by the meter prior to entry to the programming mode. Make a note of this value as it cannot be otherwise reconstructed once the new zero setting has been completed. Depress \square . The basic programming menu will reappear on the display with the "Zero Setting" item selected.

The new zero setting will become effective upon leaving the meter programming mode. At the same time, three flashing exclamation marks will appear on the display showing the actual flow rate values.

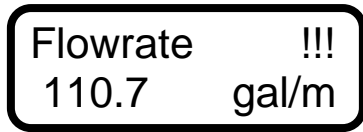



The flow-rate display image with the zero setting effective.

The actual zero setting can be changed at any time by repeating the above “Zero Setting” procedure.

Cancellation of the actual zero flow-rate setting:





Menu: Zero setting, depress 

The display will read “Setting Completed” and show the flow rate as indicated by the meter prior to entry to the programming mode. Depress . The display will read “Setting Cancelled” while the flow-rate value will remain unchanged. Depress . The basic programming menu will reappear on the display with the “Zero Setting” item selected. The cancellation of zero setting will take effect upon leaving the meter programming mode. The three flashing exclamation marks on the flow-rate display will disappear.

7.1.10. 100 per cent

Default value of the “100 Percent” quantity is Qmax as specified for the sensor DN (see the table of minimum and maximum flow rates in section 4.1.1.). This default value can be reset, in particular in cases where the actual maximum flow rate is lower than Qmax.

Menu: 100 percent, depress 





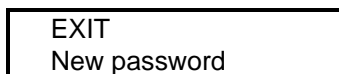

The display will read “100 Percent xxxx”. Using push-button  move the cursor to the desired decimal position and increase/decrease the selected figure by push-buttons  and , respectively. Replace xxxx by a number equal to the flow rate identified with 100%. Depress . The display will read “Value Entered Press Any Key”. Press any key, preferably . The basic programming menu will reappear on the display.

7.1.11. Exit



Select “Exit” to leave the programming mode and protect the meter from any unauthorised programming action.









Menu: Exit, depress 



Page through the menu using push-buttons  (direction downwards) and  (upwards). The selected menu item appears on the first line with the first character blinking. Select “Exit” and depress . The display will read “Write To EEPROM Press Any Key”. Press any key, preferably . The meter programming mode will be terminated and the data display menu will appear on the display. Use push-buttons  and  to page downwards and upwards through the menu items.

Select “New password” to cancel the existing password and define a new password enabling entry into the Parameter Setting mode.

Menu: Exit, depress  / New password, depress 

The display will read "Password 0000". Using push-button  move the cursor to the desired decimal position and increase/decrease the selected figure by push-buttons  and , respectively. Enter the new password and depress . The display will read "Value Entered Press Any Key". Press any key, preferably . The Exit menu will reappear on the display. Select the Exit item and depress . The display will read "Write To EEPROM Depress Any Key". Press any key, preferably . This command will terminate the programming mode and bring the data display menu on the meter display. Unless the programming procedure is terminated in this way, the flow meter parameters will not be protected by a password. Page through the menu items using push-buttons  (direction downwards) and  (upwards).

7.2. The Parameter Setting Menu

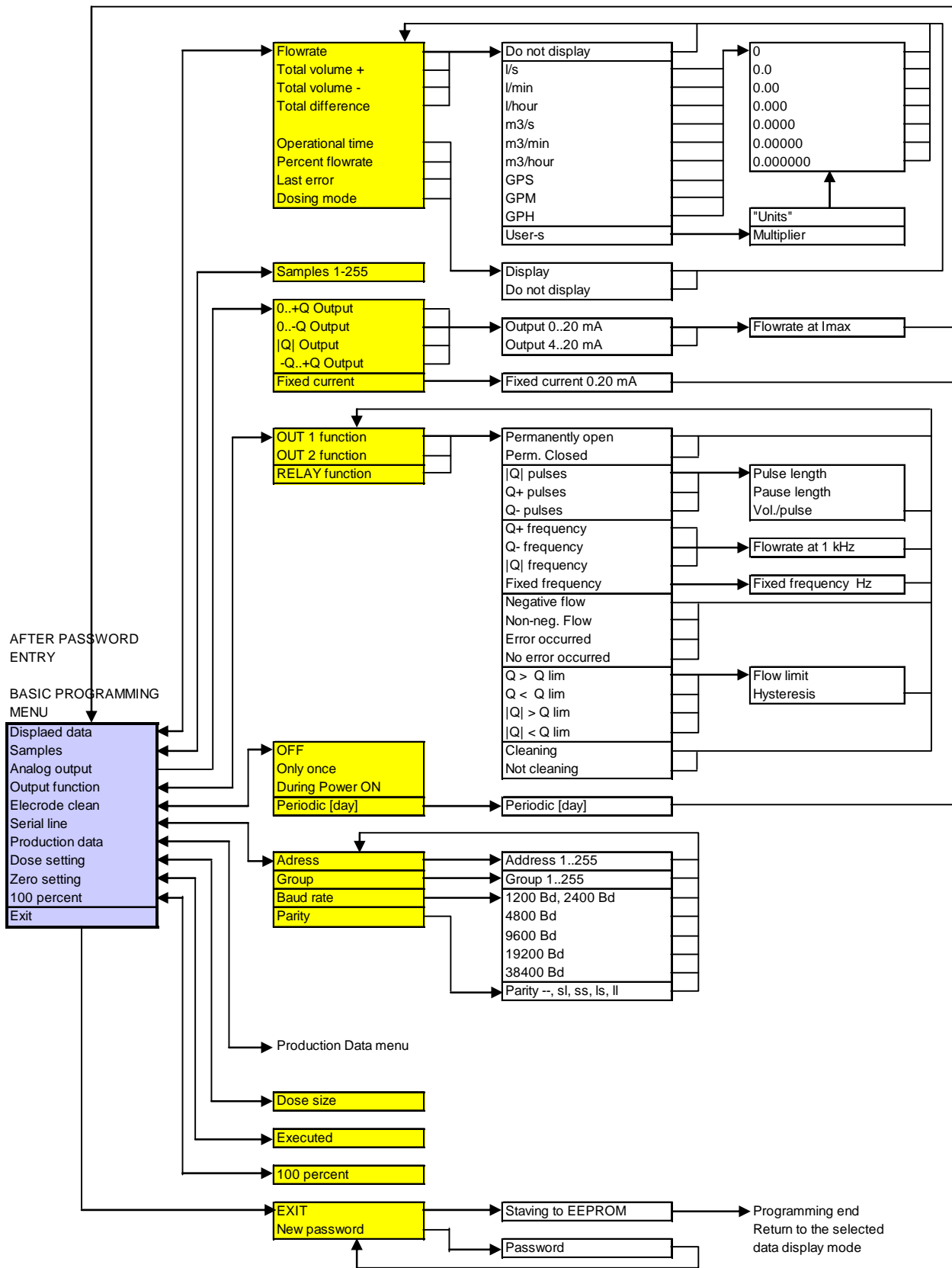

7.3. The Production Data Menu

AFTER PASSWORD
ENTRY

BASIC PROGRAMMING
MENU

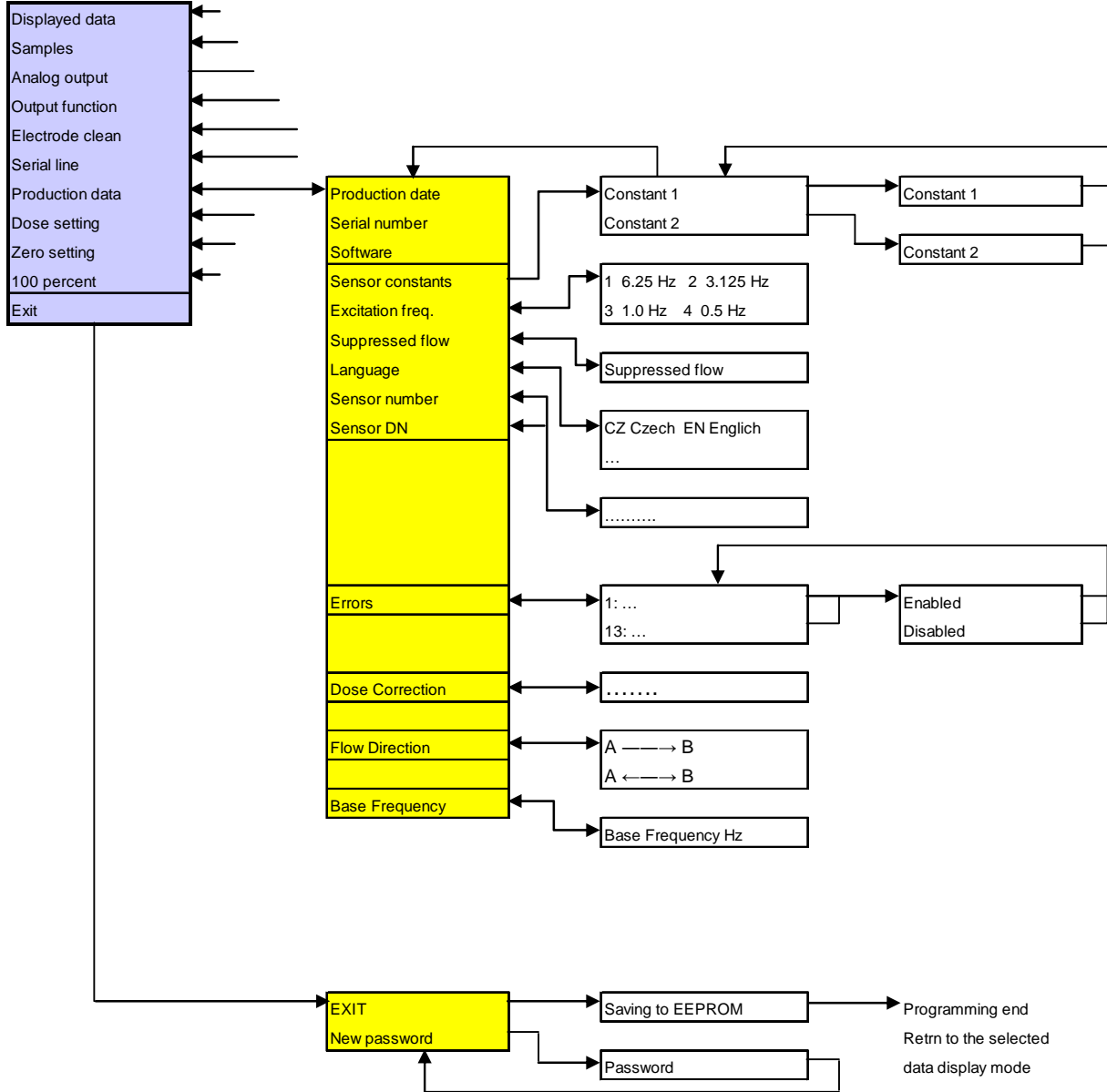

8. ERROR CLEARING AND METER REPAIR PROCEDURES

Error removal and meter repair activities should be reserved to duly qualified staff skilled in maintenance of electronic equipment and acquainted with the labour safety rules applicable to the plant concerned. On request, the meter manufacturer will provide training for such staff. The manufacturer's responsibility for any meter damage due to incorrect handling is precluded.

Prior to any work on the meter such as disconnection or removal of printed circuit boards, sensor disconnection, dismantling of the display unit, keyboard etc., make sure that the supply voltage is disconnected. At all times, be aware of the danger of electric shock.

8.1. Replacement PC Boards

Processor board including FNP5 display unit
Analog board FNA5
Power source board FNZ5
Terminal board FNS5
Keyboard
Display unit

Program and Simulation Software

Project design, assembly and service manual NORMAG
SF 1.0 sensor simulator plus connecting cable to NORMAG meter (Es90254K/a)
Floset 2.0 program (distributor Es90503D, customer Es90504D)
Personal computer with Windows 2000 or a higher upgrade thereof
USB 2.0 communication cable (with connector USB, type A at one end and connector USB, type B at the other end)
Fixture for checking outputs of NORMAG including flat connecting cable (Es90355K/a)

8.3. Flow-meter Repair Procedure

Prior to any maintenance or repair action on the internal parts of the meter control unit including the power source, PC boards, display unit, keyboard etc. make sure that the supply voltage is disconnected. Warning: disregarding this instruction implies risk of electric shock.

A flow meter in the ECONOMIC configuration can be tested using a computer connected to the meter by means of an USB serial communication line and using the FLOSET program. Alternatively, connect a display unit and keyboard to the FNP5 processor board of the meter to be checked or repaired and carry out the test as with the COMFORT configuration.

The meter in the COMFORT configuration includes a keyboard and display unit. The procedures described in this manual are focused on identification of a defective board or system component. The serviceman shall have available replacement boards tested and preset by the meter manufacturer. The repair procedure consists of replacement and checks on the condition of each system component (PC board) in turns. To exclude the possibility of a defect in the flow sensor, it should be disconnected and a sensor simulator SF 1.0 connected in its stead.

Under normal meter operation, the display backlight is off. To turn it on, depress any key. The display will show the latest selection of the measured parameter.

The self-diagnostic feature of the electronic unit concerns errors E0 through to E13. The indicated error is accompanied by a brief error description. More detailed description of the error conditions is included section 6.5.3 of this Manual. The operator may acknowledge the error indication by depressing key , whereby the error message will disappear and the previous image/message return to the display. Should the error be of a lasting nature, the error message will eventually reappear. Then proceed with repair, taking into account the error type concerned.

Remove the cover at the rear side of the electronic unit box. The cover is held position by means of six socket screws. With the cover removed, loosen and remove two RSK pin nuts using size 5 Alien wrench. Then the front panel can be lifted off (mind the flat keyboard cable). Disconnect the keyboard. Pull out the electronic circuit block including the FNA5, FNP5 and FNZ5 boards by some 20mm, disconnect the connector of the flow sensor on the analog board FNA5 and remove the block from the unit box. When re-assembling the unit, proceed in reverse order of the above steps.

When replacing the processor (FNP5) board, set the flow-meter configuration with respect to the flow sensor used.



Upon replacement of the analog (FNA5) board, the current output calibration at 4.00mA and 20.00mA will be disturbed.

When replacing the terminal (FNS5) board, mind the L165V integrated circuit mounted on an insulation plate and attached onto the unit box body.

The power source (FNZ5) board is fitted onto the analog (FNA5) board with its position secured by nuts M3. The keyboard replacement shall be done at the manufacturer's plant. The keyboard shall be tight-fitted onto the front unit panel to ensure the overall system protection class IP 67.

Flow-meter error	Error removal/rectification
No text on display, no back light, no reaction to keyboard commands	Unscrew bolts and remove cover lid on terminal board. Check the power source voltage on FNS5 and the condition of fuse on FNS5; if necessary, replace power board FNZ5 and/or terminal board FNS5.
Nonsensical reading appearing on display	Turn off and on power source, perform the initial meter setting procedure (see below); if need be, replace processor board FNP5 and/or keyboard.
Display shows flow-rate values and does not react to keyboard commands	Replace processor board FNP5 and/or keyboard.
Upon depressing a key on keyboard, display back light fails to appear	Replace processor board FNP5.
Meter diagnostics system reports error E-000	No error.
E-001	Replace power-source board (FNP5).
E-002, E-003, E-004	Incorrectly set output parameters (OUT1, OUT2, OUT3).
E-005	Electromagnetic interference from external sources too high.
E-006	Not fully flooded piping or defective electrode(s) indicating this condition Replace analog board FNA5.
E-007	Check sensor connection (coil feeding lines), replace analog board FNA5, replace terminal board L165V.
E-008	Replace power source board FNZ5, processor board FNP5 and/or analog board FNA5.

E-009	Replace power source board FNZ5, processor board FNP5 and/or analog board FNA5.
E-010	Replace analog board FNA5 and/or processor board FNP5.
E-011	Incorrect setting of current output.
E-012	Replace analog board FNA5, processor board FNP5 and/or terminal board FNS5.
E-013 – not used, has no influence to the flow meter operation	Check sensor connection (electrodes), replace analog board FNA5 and/or processor board FNP5.
Irregular function of analog output	Check analog output using the “fixed-current” mode with Amp-meter connected at the output; replace analog board FNA5, terminal board FNS5 and/or processor board FNP5.
Irregular function of outputs OUT1 and/or OUT2.	Check outputs using the “open” and “closed” modes with power source on and loading resistor connected to the output; replace analog board FNA5, terminal board FNS5 and/or processor board FNP5.
Irregular function of output relay	Check output relay using the “open” and “short-circuit” modes with Ohm-meter connected at the output; replace terminal board FNS5, analog board FNA5 and/or processor board FNP5
Unstable flow-rate readings on display	In reference to meter manual, check the sensor and measured fluid earthing connections; in the case of distributed meter version, check signal interference via cable connecting meter sensor and electronic unit (connect sensor simulator at cable end), and interference via power supply cable (use line-voltage filter).

The initial flow-meter setting procedure: With the meter power source turned off, depress simultaneously and keep depressed keys  and , turn on the power, and wait till the display starts showing the flow-rate values. This operation is used to activate the meter electronic unit in production. The initialisation procedure cancels previous meter calibration and output settings and replaces these by factory-preset parameters. Therefore, in the next step, the customised meter setting needs be performed. There are two possible methods available to do that:

- 1) Parameter setting via the meter keyboard. Enter the programming menu using password “0000” (see the Project design, assembly and service manual NORMAG). Enter the parameters specified on the sensor rating plate: excitation frequency, threshold (suppressed) flow rate, language, sensor number and DN. Further it is necessary to define fluid volume units to be displayed and to set up the output configuration.
- 2) Parameter setting using a computer and the USB serial communication line. The programming software (Floset 2.0) is supplied by the manufacturer, Elis Plzeň a.s. Fill in the meter-specific data into the respective Floset 2.0 tables and store them into the meter memory unit. A more practical way of parameter setting is re-writing the pre-set values by the meter configuration file (system production series number.flh). Feed the configuration file into the Floset 2.0 program and store it into the meter memory. The configuration file can be obtained from the meter manufacturer.

8.3.1. KV 1.0 Fixture for checking the meter outputs

Schematic drawing

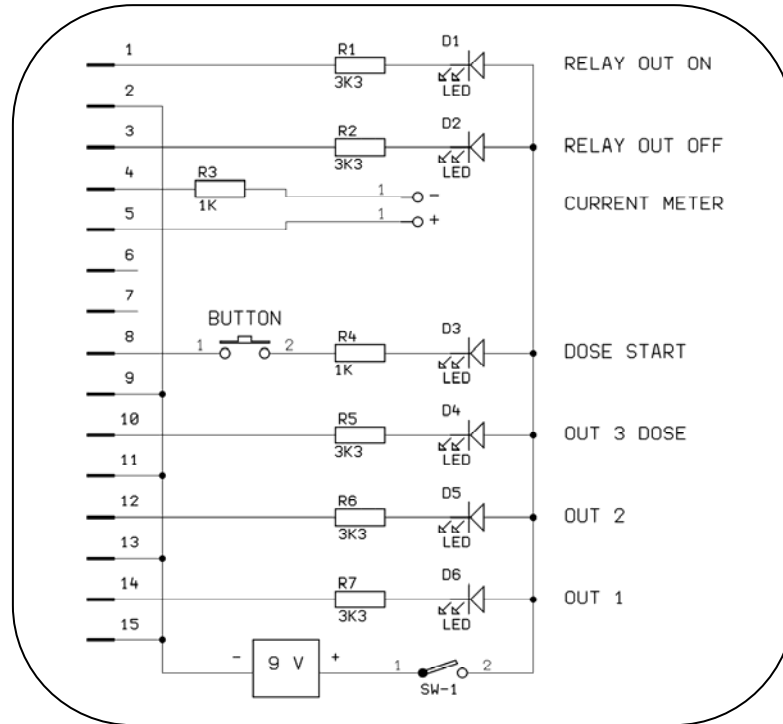

Fixture application

Disconnect external equipment from the meter terminal board. Connect fixture KV 1.0 to the terminal board of the NORMAG flow meter under test using a flat cable. Make sure that the fixture terminals are connected to corresponding meter terminals. Switch on the fixture battery. Enter the programming menu (see the meter manual).

Checking the analog (current) output:

Set fixed current at specific value, e.g. 10.0mA. Connect Amp meter into the respective socket contacts on the fixture and check the current value.

Checking output OUT1:

Select the “short-circuit (Closed)” mode and check that signal light OUT1 will light up. Select the “open-circuit (Open)” mode and the same signal light should go out.

Checking output OUT2:

Select the “Closed” mode and check that signal light OUT2 will light up. Select the “Open” mode and the same signal light should go out.

Checking the relay function:

Select the “Closed” mode and the signal light associated with the contact indicating the energised relay status (RELAY OUT CLOSED) will light up. Select the “Open” mode and the signal light indicating the energised relay status should go out and the signal light associated with the normally closed contact (RELAY OUT OPEN) will light up.

Checking the dosing function (DOSE START and OUTPUT3):

Select the “Dosing Display” mode. The dose size may be set at 500 liters or otherwise. Return to the “Dosing Display” mode of operation. Depress push-button DOSE START on the verification fixture. While the push-button is depressed, the DOSE START signal light will be up and DOSE OUTPUT3 signal light will be off. Provided the fluid flows or it is simulated by Simulator SF 1.0, dosing starts immediately. Signal light OUTPUT3 DOSE will light up following completion of the dosing operation.

Turn the battery switch into the OFF position.

Upon completion of the above checks, disconnect the KV 1.0 fixture from the meter terminal board. Then connect all co-operating devices and equipment to the unit as they were before. It is also of utmost importance to restore completely the original settings of all outputs.

8.3.2. Checking the condition of flow-meter sensor (the compact meter version)

To check the sensor condition, dismantle the electronic unit so as to gain access to the sensor connector. Proceed as follows:

Remove the cover at the rear side of the electronic unit box. The cover is held position by means of six socket screws. With the cover removed, loosen and remove two RSK pin nuts using size 5 Alien wrench. Then the front panel can be lifted off (mind the flat keyboard cable). Disconnect the keyboard. Pull out the electronic block including the FNA5, FNP5 and FNZ5 boards by some 20mm, disconnect the connector of the flow sensor from the analog board FNA5 and remove the block from the unit box. When re-assembling the unit, proceed in reverse order of the above steps.

8.3.2.1. Measurements to be performed on sensor with no fluid inside (the lining is dry)

Schematic diagram: a particular sensor need not include all the depicted electrodes

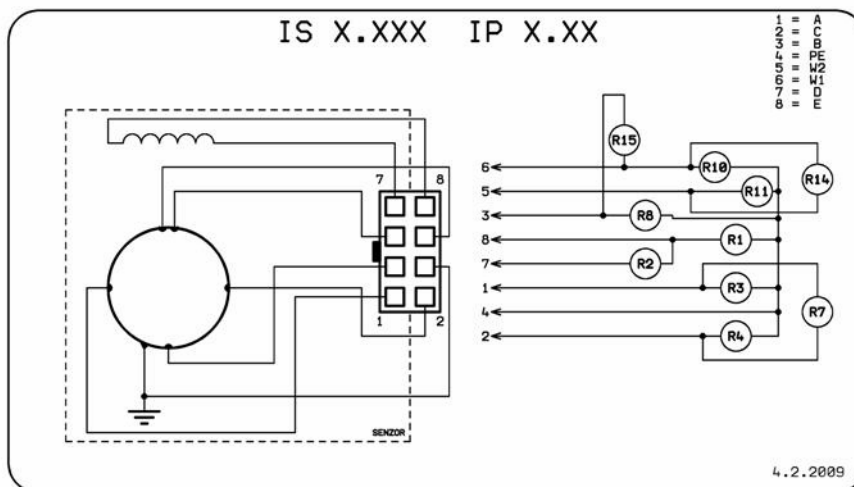

Example: Measurement of R1. Connect Ohm-meter to connector pins 5 and 2 and measure resistance. Then exchange the Ohm-meter leads and measure resistance again. Calculate the average value of the two measurements and enter it as "Measured Value" into the table below.

Parameter	Description	Measured value
R1	Coil to sensor body insulation resistance (>2MΩ)	
R2	Excitation coil resistance (36 to 44Ω)	
R3	Measuring electrode to sensor body insulation resistance (>2MΩ)	
R4	Measuring electrode to sensor body insulation resistance (>2MΩ)	
R5	Measuring electrode to connector connection (short circuit)	
R6	Measuring electrode to connector connection (short circuit)	
R7	Insulation resistance between measuring electrodes (>2MΩ)	
R8	Earthing electrode to sensor body insulation resistance (>2MΩ)	
R9	Earthing electrode to connector connection (short circuit)	
R10	Dry-condition electrode to sensor body insulation resistance (>2MΩ)	
R11	Dry-condition electrode to sensor body insulation resistance (>2MΩ)	
R12	Dry-condition electrode to connector connection (short circuit)	
R13	Dry-condition electrode to connector connection (short circuit)	
R14	Insulation resistance between dry-condition electrodes (>2MΩ)	

Comments:

If the electrodes indicating the not fully flooded (dry) piping condition are not included in the sensor configuration, connector pins 7 and 8 are shorted and parameters R10 through to R13 need not be measured. The R14 measurement will indicate a short-circuit condition.

If the earthing electrode is missing, connector pin 6 remains unconnected and parameters R8 and R9 need not be measured.

The earthing electrode can be connected with the sensor body internally. In such case connector pin 6 is not connected.

8.3.2.2. Checking the condition of flow-meter sensor fitted into piping and flooded with the measured fluid

The sensor earthing electrode is connected to the piping or earthing rings.

Schematic diagram: A particular sensor need not include all the depicted electrodes

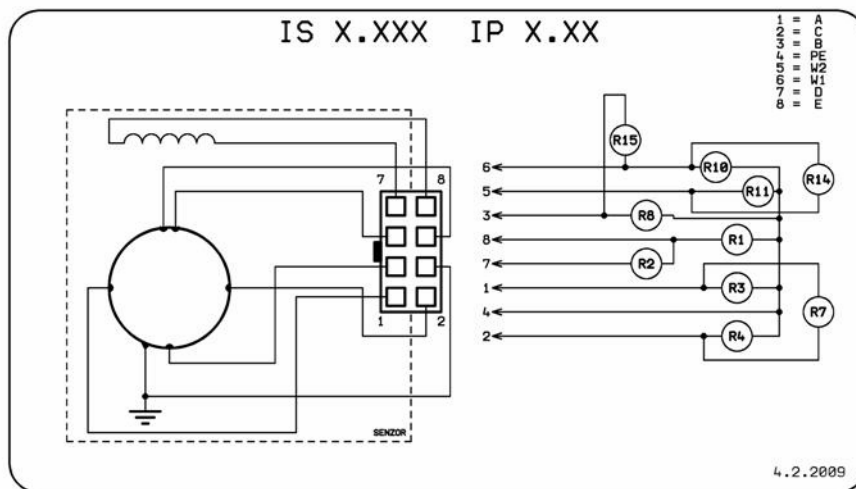

Example: Measurement of R1. Connect Ohm-meter to connector pins 5 and 2 and measure resistance. Then exchange the Ohm-meter leads and measure resistance again. Calculate the average value of the two measurements and enter it as "Measured Value" into the table below.

Parameter	Description	Measured value
R1	Coil to sensor body insulation resistance (>2MΩ)	
R2	Excitation coil resistance (36 to 44Ω)	
R3	Fluid resistance between measuring electrode and sensor body	
R4	Fluid resistance between measuring electrode and sensor body	
R7	Fluid resistance between measuring electrodes	
R8	Fluid resistance between earthing electrode and sensor body	
R10	Fluid resistance between dry-condition electrode and sensor body	
R11	Fluid resistance between dry-condition electrode and sensor body	
R14	Fluid resistance between dry-condition electrodes	
R15	Fluid resistance between earthing and dry-condition electrodes	

Comments:

If the electrodes indicating the not fully flooded (dry) piping condition are not included in the sensor configuration, connector pins 7 and 8 are shorted and parameters R10 and R11 need not be measured. The R14 measurement shall indicate a short-circuit condition.

If the earthing electrode is missing, connector pin 6 remains unconnected and parameters R8 and R15 need not be measured.

The earthing electrode can be connected with the sensor body internally. In such case connector pin 6 is not connected.

8.3.3. Checking the condition of flow-meter sensor (the distributed meter version with the remote electronic unit accommodated in an IP-67 box)

To check the condition of the meter sensor, remove the lid on the sensor terminal box. Disconnect the cable to the associated electronic unit and perform the required sensor parameter measurements. In the case of the IP-67 design version, the terminals are readily accessible. With IP-68 design, the terminals including the cable end are sealed with packaging compound and cannot be accessed.

8.3.3.1. Measurements to be performed on sensor with no fluid inside (the lining is dry)

Schematic diagram: A particular sensor need not include all the depicted electrodes

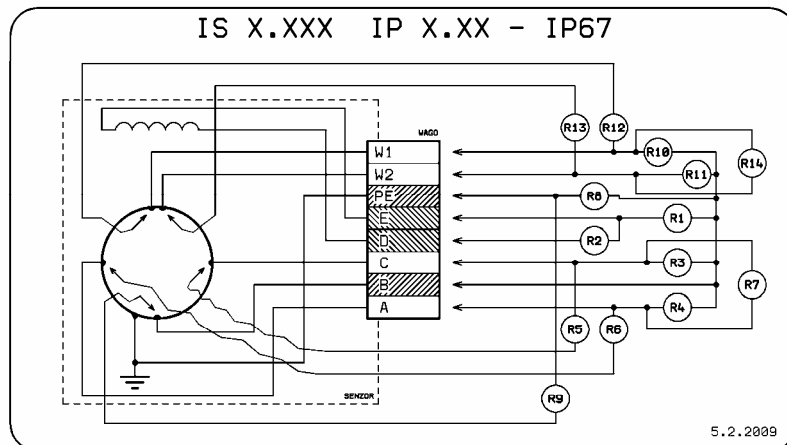

Example: Measurement of R1. Connect Ohm-meter to connector pins 5 and 2 and measure resistance. Then exchange the Ohm-meter leads and measure resistance again. Calculate the average value of the two measurements and enter it as "Measured Value" into the table below.

Parameter	Description	Measured value
R1	Coil to sensor body insulation resistance (>2MΩ)	
R2	Excitation coil resistance (36 to 44Ω)	
R3	Measuring electrode to sensor body insulation resistance (>2MΩ)	
R4	Measuring electrode to sensor body insulation resistance (>2MΩ)	
R5	Measuring electrode to connector connection (short circuit)	
R6	Measuring electrode to connector connection (short circuit)	
R7	Insulation resistance between measuring electrodes (>2MΩ)	
R8	Interconnection between connector points 2 and 6 (short circuit)	
R9	Earthing electrode to sensor body connection (short circuit)	
R10	Dry-condition electrode to sensor body insulation resistance (>2MΩ)	
R11	Dry-condition electrode to sensor body insulation resistance (>2MΩ)	
R12	Dry-condition electrode to connector connection (short circuit)	
R13	Dry-condition electrode to connector connection (short circuit)	
R14	Insulation resistance between dry-condition electrodes (>2MΩ)	

Comments:

If the electrodes indicating the not fully flooded (dry) piping condition are not included in the sensor configuration, connector pins 7 and 8 are free and resistances R10 through to R14 need not be measured. If the earthing electrode is missing, parameter R9 need not be measured.

8.3.3.2. Checking the condition of flow-meter sensor fitted into piping and flooded with the measured fluid

The sensor earthing electrode is connected to the piping or earthing rings.

Schematic diagram: A particular sensor need not include all the depicted electrodes

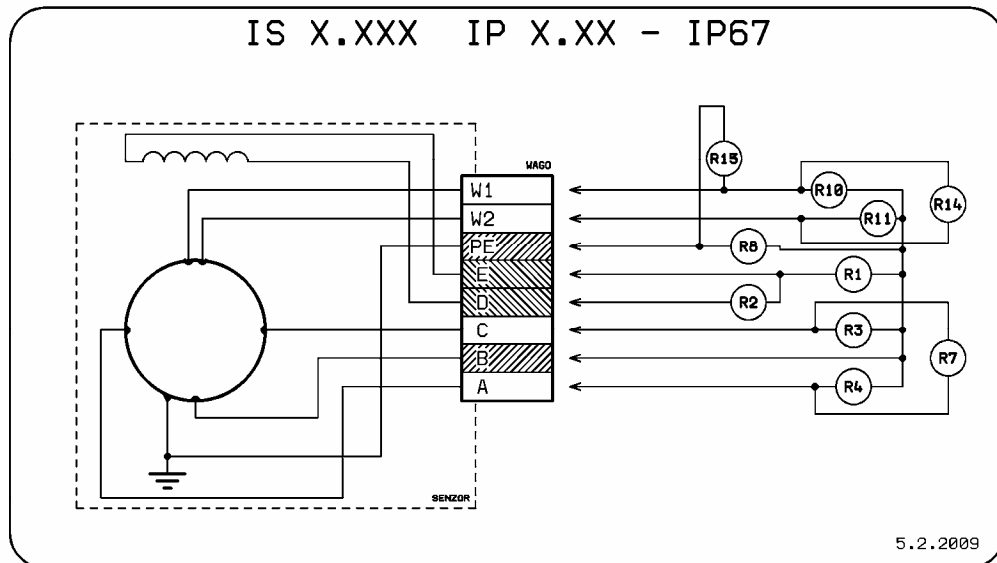

Example: Measurement of R1. Connect Ohm-meter to connector pins 5 and 2 and measure resistance. Then exchange the Ohm-meter leads and measure resistance again. Calculate the average value of the two measurements and enter it as "Measured Value" into the table below.

Parameter	Description	Measured value
R1	Coil to sensor body insulation resistance (>2MΩ)	
R2	Excitation coil resistance (36 to 44Ω)	
R3	Fluid resistance between measuring electrode and sensor body	
R4	Fluid resistance between measuring electrode and sensor body	
R7	Fluid resistance between measuring electrodes	
R8	Interconnection between connector points 2 and 6 (short circuit)	
R10	Fluid resistance between dry-condition electrode and sensor body	
R11	Fluid resistance between dry-condition electrode and sensor body	
R14	Fluid resistance between dry-condition electrodes	
R15	Fluid resistance between earthing and dry-condition electrodes	

Comments:

If the electrodes indicating the not fully flooded (dry) piping condition are not included in the sensor configuration, connector pins 7 and 8 are free and resistances R10, R11 and R14 need not be measured. If the earthing electrode is missing, parameter R15 need not be measured.

8.3.3.3. Checking the condition of the cable connecting sensor and associated electronic unit

Important notice: Prior to checking the condition of the connecting cable, disconnect the flat connector on the side of the electronic unit. After the check, plug the connector in again.

Remove the cover at the rear side of the electronic unit box. The cover is held position by means of six socked screws. With the cover removed, loosen and remove two RSK pin nuts using size 5 Alien wrench. Then the front panel can be lifted off (mind the flat keyboard cable). Disconnect the keyboard. Pull out the electronic block including the FNA5, FNP5 and FNZ5 boards by some 20mm, disconnect the connector of the flow sensor from the analog board FNA5 and remove the block from the unit box. When re-assembling the unit, proceed in reverse order of the above steps.

During the inspection, the connecting cable shall be disconnected from both the meter sensor and the electronic unit. Check the integrity of individual cable conductors, insulation resistance between the cable conductors and insulation resistance between each cable conductor and shielding. The shielding connection is on the side of the meter sensor only.

8.3.4. Checking the condition of flow-meter sensor (the distributed meter version with the remote electronic unit accommodated in an IP-68 box)

The sensor and connecting cable are to be checked simultaneously. On the side of the electronic unit, the cable is terminated by a 9-pin Buccaneer connector via which all measurements shall be done.

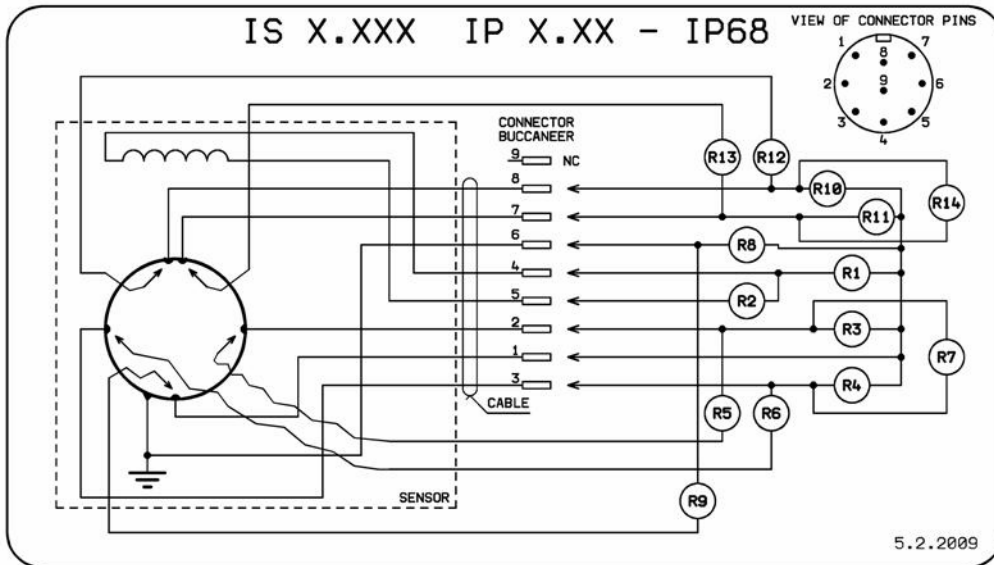

Example: Measurement of R1. Connect Ohm-meter to connector pins 4 and 1 and measure resistance. Then exchange the Ohm-meter leads and measure resistance again. Calculate the average value of the two measurements and enter it as "Measured Value" into the table below.

Parameter	Description	Measured value
R1	Coil to sensor body insulation resistance (>2MΩ)	
R2	Excitation coil resistance (36 to 44Ω)	
R3	Measuring electrode to sensor body insulation resistance (>2MΩ)	
R4	Measuring electrode to sensor body insulation resistance (>2MΩ)	
R5	Measuring electrode to connector pin connection (short circuit)	
R6	Measuring electrode to connector pin connection (short circuit)	
R7	Insulation resistance between measuring electrodes (>2MΩ)	
R8	Interconnection of connector pins 1 and 6 (short circuit)	
R9	Earthing electrode to sensor body connection (short circuit)	
R10	Dry-condition electrode to sensor body insulation resistance (>2MΩ)	
R11	Dry-condition electrode to sensor body insulation resistance (>2MΩ)	
R12	Dry-condition electrode to connector pin connection (short circuit)	
R13	Dry-condition electrode to connector pin connection (short circuit)	
R14	Insulation resistance between dry-condition electrodes (>2MΩ)	

Comments:

If the electrodes indicating the not fully flooded (dry) piping condition are not included in the sensor configuration, connector pins 7 and 8 are free and resistances R10 through to R14 need not be measured.

If the earthing electrode is missing, parameter R9 need not be measured either.

8.3.4.1. Checking the condition of flow-meter sensor fitted into piping and flooded with the measured fluid

The sensor earthing electrode is connected to the piping or earthing rings.

Schematic diagram: A particular sensor need not include all the depicted electrodes

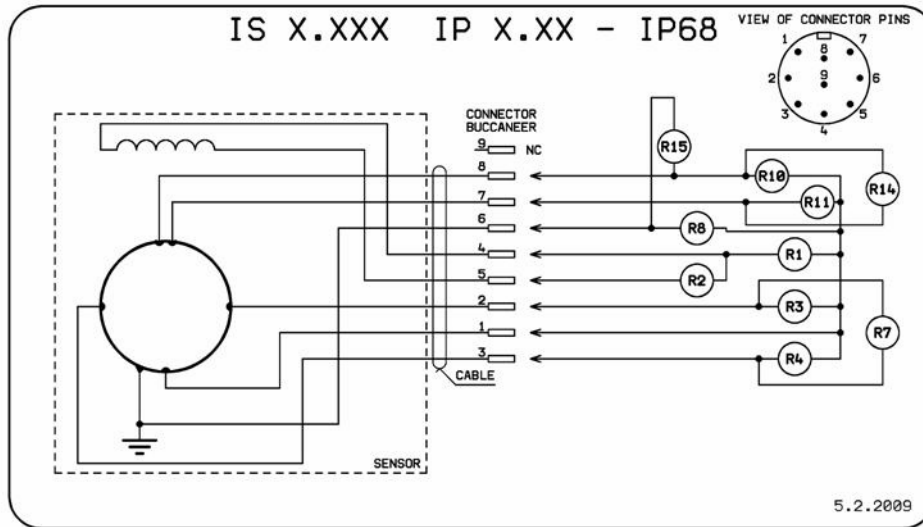

Example: Measurement of R1. Connect Ohm-meter to connector pins 4 and 1 and measure resistance. Then exchange the Ohm-meter leads and measure resistance again. Calculate the average value of the two measurements and enter it as "Measured value" into the table below.

Parameter	Description	Measured value
R1	Coil to sensor body insulation resistance (>2MΩ)	
R2	Excitation coil resistance (36 to 44Ω)	
R3	Fluid resistance between measuring electrode and sensor body	
R4	Fluid resistance between measuring electrode and sensor body	
R7	Fluid resistance between measuring electrodes	
R8	Interconnection of connector pins 1 and 6 (short circuit)	
R10	Interconnection between connector points 2 and 6 (short circuit)	
R11	Fluid resistance between dry-condition electrode and sensor body	
R14	Fluid resistance between dry-condition electrode and sensor body	
R15	Fluid resistance between dry-condition electrodes	
	Fluid resistance between earthing and dry-condition electrodes	

Comments:

If the electrodes indicating the not fully flooded (dry) piping condition are not included in the sensor configuration, connector pins 7 and 8 are free and resistances R10, R11 and R14 need not be measured.

If the earthing electrode is missing, parameter R15 need not be measured either.

8.3.5. Checking the condition of induction flow meter using the meter diagnostic module of the Floset 2.0 program

Connect your computer via an USB communication cable to the NORMAG induction flow meter. Start the Floset 2.0 program and verify the connection to the flow meter under test. Select the Diagnostics module and initialise it.

Module functions:

- reading of all measured flow-rate and volume values and indicated errors
- recording of repeated value readings into specified files
- visualisation of meter manufacturing information
- system diagnostics and printout of the diagnostic report

For more detailed information, see Guide to Floset 2.0 application.

Comment: If the meter configuration includes the RS-485 communication line interface, the diagnostic operations can be carried out via this line (provided, of course, that your computer has the necessary interface or an RS-485 converter).