

TRANSI-FLO II SERIES ***(Ultrasonic Battery Powered Flowmeters)***

USER'S MANUAL



HP-317
November 2010

H **HOFFER FLOW CONTROLS, INC.**
Perfecting Measurement™

107 Kitty Hawk Lane • P.O. Box 2145 • Elizabeth City, North Carolina 27906-2145
1-800-628-4584 • (252) 331-1997 • FAX (252) 331-2886
www.hofferflow.com • Email: info@hofferflow.com

NOTICE

HOFFER FLOW CONTROLS, INC. makes no warranty of any kind with regard to this material, including, but not limited to, the implied warranties of merchantability and fitness for a particular purpose.

This manual has been provided as an aid in installing, connecting, calibrating, operating, and servicing this unit. Every precaution for accuracy has been taken in the preparation of this manual; however, HOFFER FLOW CONTROLS, INC. neither assumes responsibility for any omissions or errors that may appear nor assumes liability for any damages that may result from the use of the products in accordance with information contained in the manual.

HOFFER FLOW CONTROLS' policy is to provide a user manual for each item supplied. Therefore, all applicable user manuals should be examined before attempting to install or otherwise connect a number of related subsystems.

During installation, care must be taken to select the correct interconnecting wiring drawing. The choice of an incorrect connection drawing may result in damage to the system and/or one of the components.

Please review the complete model number of each item to be connected and locate the appropriate manual(s) and/or drawing(s). Identify all model numbers exactly before making any connections. A number of options and accessories may be added to the main instrument, which are not shown on the basic user wiring. Consult the appropriate option or accessory user manual before connecting it to the system. In many cases, a system wiring drawing is available and may be requested from HOFFER FLOW CONTROLS.

This document contains proprietary information, which is protected by copyright. All rights are reserved. No part of this document may be photocopied, reproduced, or translated to another language without the prior written consent of HOFFER FLOW CONTROLS, INC.

HOFFER FLOW CONTROLS' policy is to make running changes, not model changes, whenever an improvement is possible. This affords our customers the latest in technology and engineering. The information contained in this document is subject to change without notice.

Return Requests / Inquiries

Direct all warranty and repair requests/inquiries to the Hoffer Flow Controls Customer Service Department, telephone number (252) 331-1997 or 1-800-628-4584. BEFORE RETURNING ANY PRODUCT(S) TO HOFFER FLOW CONTROLS, PURCHASER MUST OBTAIN A RETURNED MATERIAL AUTHORIZATION (RMA) NUMBER FROM HOFFER FLOW CONTROLS' CUSTOMER SERVICE DEPARTMENT (IN ORDER TO AVOID PROCESSING DELAYS). The assigned RMA number should then be marked on the outside of the return package and on any correspondence.

FOR **WARRANTY** RETURNS, please have the following information available BEFORE contacting HOFFER FLOW CONTROLS:

1. P.O. number under which the product was PURCHASED,
2. Model and serial number of the product under warranty, and
3. Repair instructions and/or specific problems relative to the product.

FOR **NON-WARRANTY** REPAIRS OR CALIBRATIONS, consult HOFFER FLOW CONTROLS for current repair/ calibration charges. Have the following information available BEFORE contacting HOFFER FLOW CONTROLS:

1. P.O. number to cover the COST of the repair/calibration,
2. Model and serial number of the product and
3. Repair instructions and/or specific problems relative to the product.

Limited Warranty

HOFFER FLOW CONTROLS, INC. ("HFC") warrants HFC's products ("goods") described in the specifications incorporated in this manual to be free from defects in material and workmanship under normal use and service, but only if such goods have been properly selected for the service intended, properly installed and properly operated and maintained. This warranty shall extend for a period of one (1) year from the date of delivery to the original purchaser (or eighteen (18) months if the delivery to the original purchaser occurred outside the continental United States). This warranty is extended only to the original purchaser ("Purchaser"). *Purchaser's sole and exclusive remedy is the repair and/or replacement of nonconforming goods as provided in the following paragraphs.*

In the event Purchaser believes the goods are defective, the goods must be returned to HFC, transportation prepaid by Purchaser, within twelve (12) months after delivery of goods (or eighteen (18) months for goods delivered outside the continental United States) for inspection by HFC. If HFC's inspection determines that the workmanship or materials are defective, the goods will be either repaired or replaced, at HFC's sole determination, free of additional charge, and the goods will be returned, transportation paid by HFC, using the lowest cost transportation available.

Prior to returning the goods to HFC, Purchaser must obtain a Returned Material Authorization (RMA) Number from HFC's Customer Service Department within 30 days after discovery of a purported breach of warranty, but no later than the warranty period; otherwise, such claims shall be deemed waived. See the Return Requests/Inquiries Section of this manual.

If HFC's inspection reveals the goods are free of defects in material and workmanship or such inspection reveals the goods were improperly used, improperly installed, and/or improperly selected for service intended, HFC will notify the purchaser in writing and will deliver the goods back to Purchaser upon (i) receipt of Purchaser's written instructions and (ii) the cost of transportation. If Purchaser does not respond within thirty (30) days after notice from HFC, the goods will be disposed of in HFC's discretion.

HFC does not warrant these goods to meet the requirements of any safety code of any state, municipality, or other jurisdiction, and Purchaser assumes all risk and liability whatsoever resulting from the use thereof, whether used singly or in combination with other machines or apparatus.

This warranty shall not apply to any HFC goods or parts thereof, which have been repaired outside HFC's factory or altered in any way, or have been subject to misuse, negligence, or accident, or have not been operated in accordance with HFC's printed instructions or have been operated under conditions more severe than, or otherwise exceeding, those set forth in the specifications for such goods.

THIS WARRANTY IS EXPRESSLY IN LIEU OF ALL OTHER WARRANTIES, EXPRESSED OR IMPLIED, INCLUDING ANY IMPLIED WARRANTY OF MERCHANTABILITY OR FITNESS FOR A PARTICULAR PURPOSE. HFC SHALL NOT BE LIABLE FOR ANY LOSS OR DAMAGE RESULTING, DIRECTLY OR INDIRECTLY, FROM THE USE OR LOSS OF USE OF THE GOODS. WITHOUT LIMITING THE GENERALITY OF THE FOREGOING, THIS EXCLUSION FROM LIABILITY EMBRACES THE PURCHASER'S EXPENSES FOR DOWNTIME OR FOR MAKING UP DOWNTIME, DAMAGES FOR WHICH THE PURCHASER MAY BE LIABLE TO OTHER PERSONS, DAMAGES TO PROPERTY, AND INJURY TO OR DEATH OF ANY PERSONS. HFC NEITHER ASSUMES NOR AUTHORIZES ANY PERSON TO ASSUME FOR IT ANY OTHER LIABILITY IN CONNECTION WITH THE SALE OR USE OF HFC'S GOODS, AND THERE ARE NO ORAL AGREEMENTS OR WARRANTIES COLLATERAL TO OR AFFECTING THE AGREEMENT. PURCHASER'S SOLE AND EXCLUSIVE REMEDY IS THE REPAIR AND/OR REPLACEMENT OF NONCONFORMING GOODS AS PROVIDED IN THE PRECEDING PARAGRAPHS. HFC SHALL NOT BE LIABLE FOR ANY OTHER DAMAGES WHATSOEVER INCLUDING INDIRECT, INCIDENTAL, OR CONSEQUENTIAL DAMAGES.

CONTENTS

1. Warnings	1
1.1 Meter Handling	1
2. Introduction	3
2.1 Model Number Designation	4
3. Features and Specifications	5
3.1 Ultrasonic sensor unit	6
3.2 Electronic unit	6
3.3 Technical Specifications	7
4. Installation	9
4.1 Electronic Unit Installation	11
4.2 Wiring	11
4.3 The Meter Mount Version	12
4.4 Pulse Output	13
4.5 Current Output	13
4.6 The Remote Mount Version	14
4.7 Recommended Sealing Points	15
5. Operation	16
5.1 Reading From the Meter Display	16
6. Communication	18
6.1 Communication Via Optical Interface	18
6.2 Communication Via RS 232	19
6.3 Communication Via M-Bus	19
7. Error Functions	20
8. Battery Life and Replacement	22

1. Warnings

Read this manual carefully and follow all recommendations.

Prior to operational, check proper tightening of the grommets and plug unused ones. Protect the electronic unit from direct sunshine.

1.1 Meter Handling

Do not lift the meter holding it by the electronic unit.

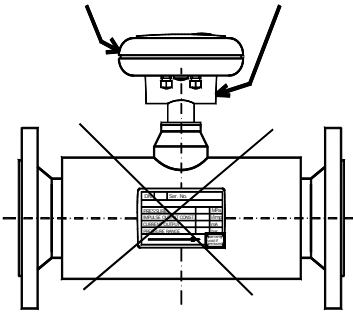

Incorrect grips on the meter assembly.

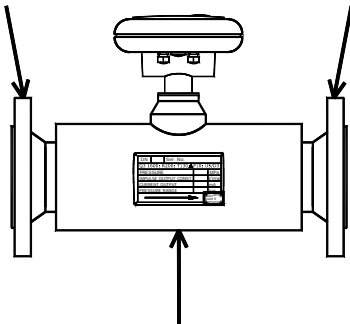

Correct grips on the meter assembly

This page intentionally left blank.

2. Introduction

Transi-flo II is a battery-powered ultrasonic flow meter for use on water and similar liquids in a fully flooded pipe. The meter is non-intrusive, includes no moving parts, and requires no external power supply. The Transi-flo II meter is noted for high measurement accuracy and long term stability over a wide range of measured values.

The meter uses dual probe single-beam impulse transit-time method. Each probe functions as the transmitter and receiver in turns so that the ultrasonic wave travels in and against the flow direction.

Measurements of flow rate, total volume and pressure are recorded and stored in an internal data logger. The stored data is retrieved via optical interface or RS232 communication line. Analog output and pulse output signals are available for further processing.

The Transi-flo II meter may be mounted directly on pipe or mounted remotely up to 15 ft away from sensor.

The meter complies with the requirements of the EN 14154 standard.

Introduction 4

2.1 Model Number Designation

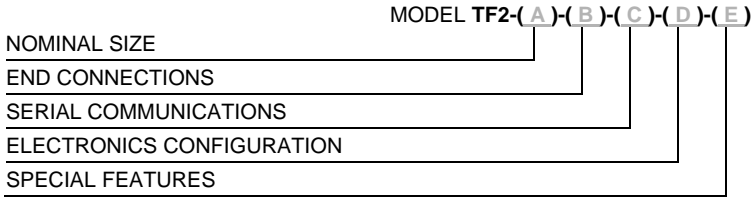

NOMINAL SIZE

MODEL TF2-(A)-()-()-()-()-()-()

SIZE (A):	1 1/2"	6"
	2"	8"
	3"	10"
	4"	12"

END CONNECTION

MODEL TF2-()-(B)-()-()-()

OPTION (B)

(F1CS) 150# RF CARBON STEEL FLANGES

(F1SS) 150# RF STAINLESS STEEL FLANGES

SERIAL COMMUNICATIONS

MODEL TF2-()-()-(C)-()-()

OPTION (C)

(1) RS 232

ELECTRONICS CONFIGURATION

MODEL TF2-()-()-()-(D)-()

OPTION (D)

(1) INTEGRAL RATE AND TOTAL INDICATOR WITH
FACE MOUNT CONTROLS, IP 67

(2) REMOTE ELECTRONICS FOR IP 67 WITH 19-FT CABLE

(3) REMOTE ELECTRONICS FOR IP 68 WITH 19-FT CABLE

SPECIAL FEATURES

MODEL TF2-()-()-()-()-(E)-()-()

OPTION (E)

(X)

3. Features and Specifications

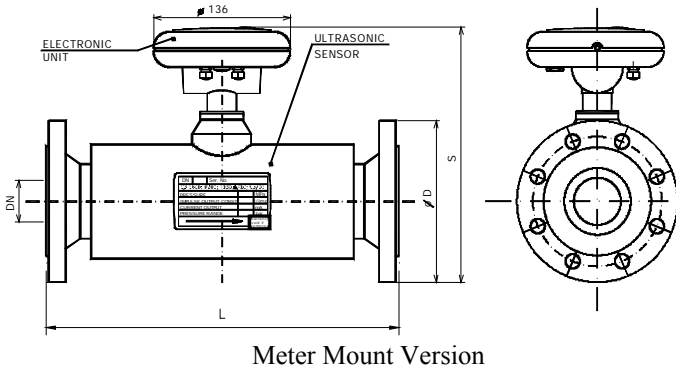

DN	32	40	50	65	80	100	125	150	200	250	300
L [mm]	360	360	360	360	360	360	360	360	450	450	450
S [mm]	230	240	250	265	280	310	340	370	430	490	550
D [mm] PN16/40	140	150	165	185	200	220/235	250/270	285/300	340/375	405/450	460/515
Weight [kg]	9	9	11.5	12	15.5	17	18.5/20.5	19.5/21.5	28.5/37.5	45.5/70.5	58.5/84.5

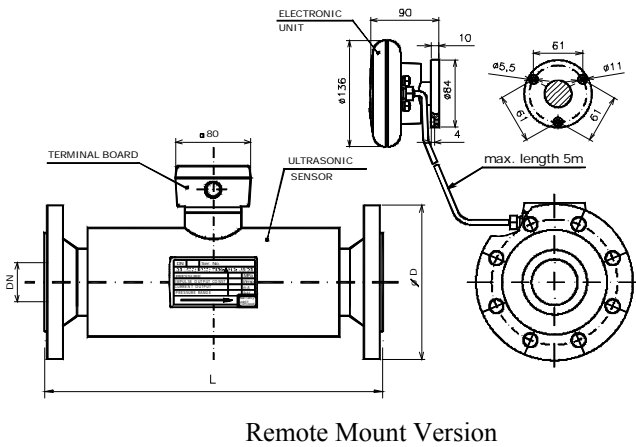

6 Features and Specifications

3.1 Ultrasonic sensor unit

The ultrasonic sensor unit consists of flow section made of stainless steel, two ultrasonic transducers, and sensor housing made of carbon steel.

3.2 Electronic unit

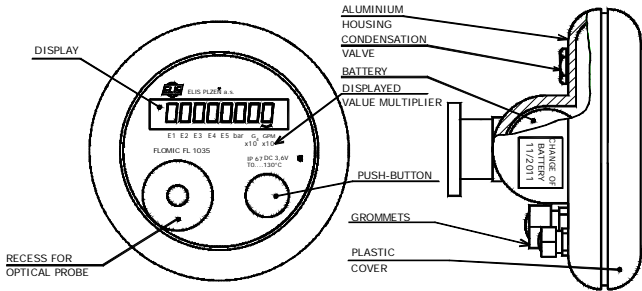

The electronic unit including a battery is enclosed in an aluminium box with a plastic lid. The box is provided with a special valve preventing moisture condensation inside the box and up to three grommets for cables.

There are two M8 grommets for 3.5 to 5mm cable for user wiring of output signals and one M12 grommet for 6.5 to 8mm to connect to sensor unit.

In the IP 68 design version, the connecting cable is attached to both the sensor and electronic units at the factory and cannot be disconnected.

The electronic unit can be mounted directly on the meter or remotely up to 15 ft.

If the electronic unit is mounted remotely, a terminal board in an aluminium enclosure is mounted on the meter. The terminal box is provided with a M12 grommet for a cable of diameter 6.5 to 8mm, a valve preventing moisture condensation inside the box and four spring-loaded WAGO terminals to which the ultrasonic probe signals are connected. Meter with a pressure option has eight WAGO terminals (see section 5.2.3 – electrical connections of a distributed meter version).

3.3 Technical Specifications

The threshold flow rate at which the meter starts to register and measure the fluid flow parameters is set at the manufacturing plant at Q_{NEC} corresponding to flow velocity of 20mm/sec. Upon customer's, request this value can be adjusted within the range of 0.1 to 25% Q_4 .

TRANSI-FLO II Flowmeter Specifications

Line Sizes:	1-1/4" to 12"
Maximum Permitted Pressure	ANSI 150# & 300# Class
Temperature Class	Meter Mounted 32.18°F to 194°F (0.1 to 90°C) Remote 32.18°F to 266°F (0.1 to 130° C)
Measurement Accuracy	According to EN 14154
Pressure Loss Class	Less than 1.5 PSI @ Max. continuous rating
Measurement Range:	(200:1 Turndown) See Chart.
Ambient Temperature	32 to 131°F (0 to 55°C)
Protection Class	IP 67 (NEMA 4X)
Flange Connections	ANSI, JIS, DIN and AS
Flow Sensor Construction Material	Carbon or Stainless Steels
Power Supply	Li Battery 3.6V/16Ah-guaranteed battery lifetime 6 years
Measurement Frequency	1Hz
Display Unit	Single-line 8-Character LCD
Outputs	Passive pulse $U = 5$ to 25V, $I_{max}=10mA$, Pulse length 2 ms
Optional meter version and functions	Passive current output 4 to 20mA, $U_{max}=24V$ Data communication via optical interface RS 232 communication interface Data archiving facility Remote meter version with sensor protection class IP 68, max. fluid temp. 302°F (150°C) Fluid pressure measurement within the range of 0-217 PSIG (0-16 Bar) Drinking-water version (with all-stainless-steel sensor)

8 Features and Specifications

This page intentionally left blank.

4. Installation

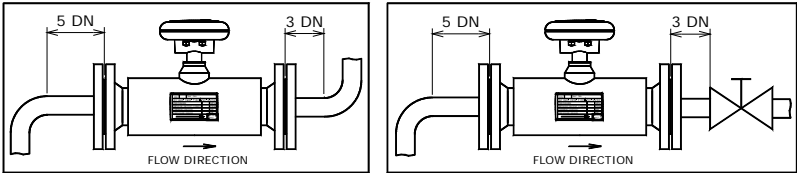

Minimum length of required straight piping sections in pipe diameters

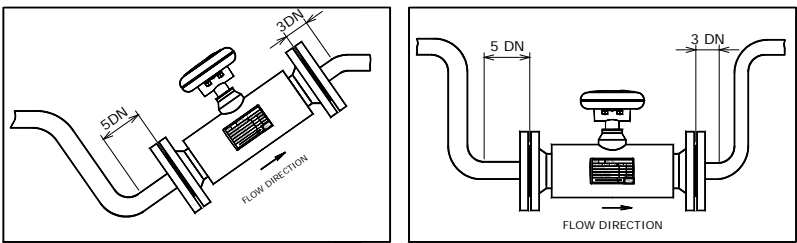

Recommended meter installation when full flooding of the piping cannot be guaranteed.

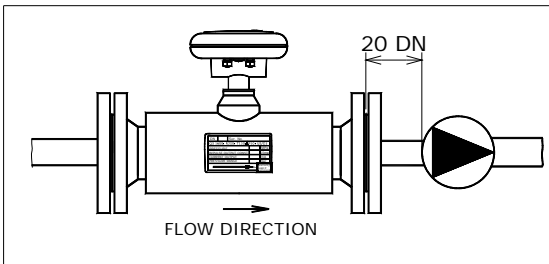

Recommended pump location

10 Installation

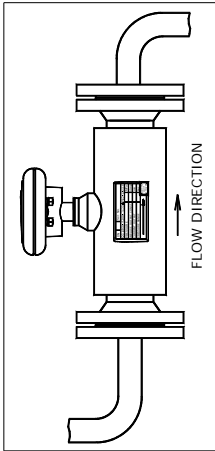

Vertical installation

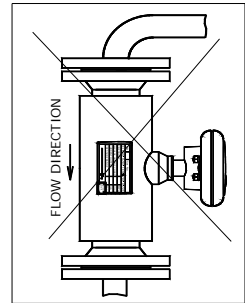
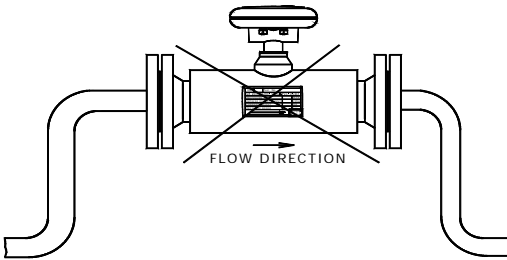

Examples of incorrect installation

4.1 Electronic Unit Installation

NOTE!

The electronic unit cannot be installed in a sealed cabinet or enclosure. For outdoor installation, it must be protected from direct sunshine by a suitable shed.

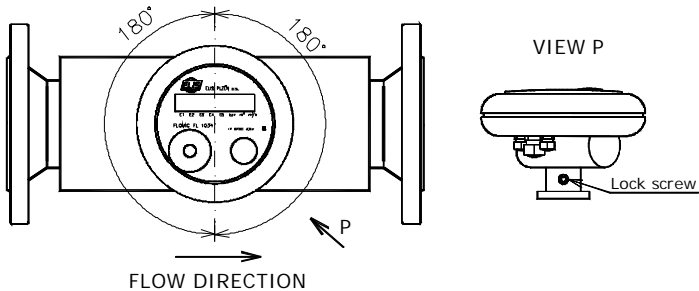

The electronic unit can be rotated 180° by loosening the set screws M5 at the unit base using an Allen wrench, size 2.5mm.

4.2 Wiring

Grounding and shielding

To prevent signal interference, the meter wiring shall be placed at least 25cm away from any live power cables. The interconnection between the meter sensor and the associated electronic unit (the distributed meter version) shall be made with a shielded cable with the shielding connected to the earth potential at the sensor terminal board. It is recommended that all output signals (the impulse, current and M-Bus outputs) be connected using shielded cables with the shielding connected to the earth potential on the side of the plant control system. The meter sensor grounding bolt shall be connected to the earth ground with conductor of cross-section of at least AWG (4mm²).

12 Installation

4.3 The Meter Mount Version

To access the terminal board, remove two M4 screws with 2mm Allen wrench from the plastic lid. Locate two 8mm slots at the bottom side of the plastic lid, insert a screwdriver into one of the slots and pry upwards to lift the lid.

Connect output signals according to the drawing below. Prior to replacing the lid, apply a thin layer of glycerine or silicon oil on the sealing O-ring.

When replacing the lid, the 3mm hole at the bottom side of the plastic lid should be fitted onto the guide pin of diameter 2.5mm press-fitted at the box bottom.

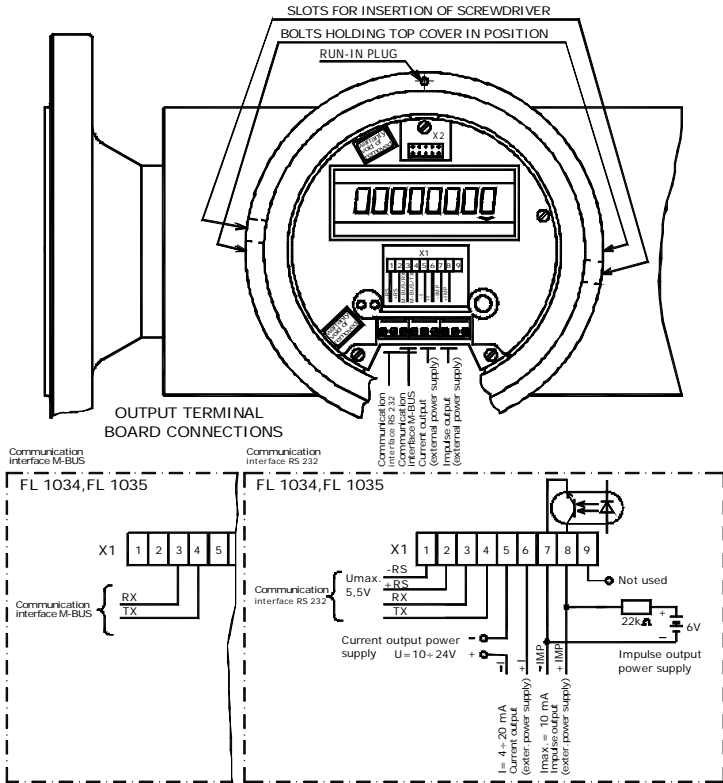

4.4 Pulse Output

Optically isolated pulse output is available at terminals 7 and 8 (terminal board X1); the default pulse length is 40 ms and can be switched to 2ms by moving jumper J5.

- J5: 1-2 2ms
- J5: 2-3 40ms

External voltage range 5-25 V
 Load current max 10mA.
 Recommended load resistance 1-47 kΩ

4.5 Current Output

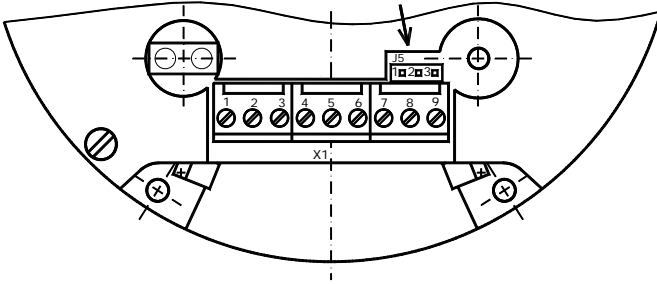

Analog output 4-20mA is available at terminals 5 and 6 of the output terminal board (X1). If flow rate exceeds the level set for 20mA, the output current remains at 20mA and the error message E4 will appear on the display (see Error Messages table below).

Analog output requires an external power source of 10 to 24VDC to be connected as shown.... The maximum allowable loop resistance (cable + load resistance) is determined by the following formula:

$$R_s [\Omega] = \frac{U \text{ source [V]} - 7}{0.02}$$

14 Installation

4.6 The Remote Mount Version

The signal cable from the electronic unit is to be connected to the respective spring-loaded WAGO terminals at terminal board X2 in the sensor unit assembly. The terminal box cover is secured by four M4 screws with 3 mm hexagonal heads.

In the IP 68 design version of the remote sensor, the connection cable to the associated electronic unit (bringing the ultrasonic probe signals to the electronic unit) is fitted on both sides at the manufacturing company.

For output signal connections refer to wiring drawing above.

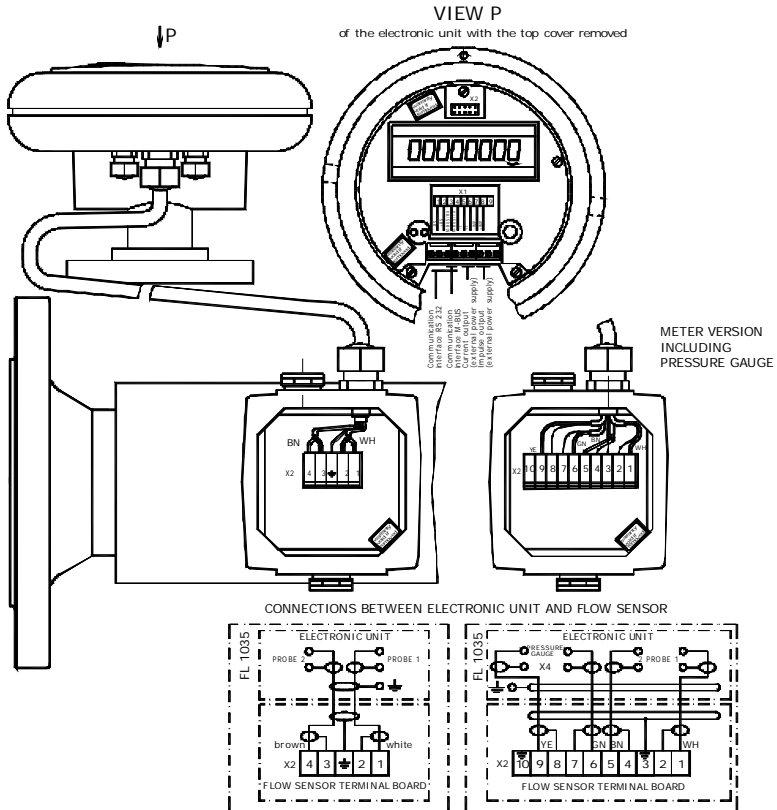

4.7 Recommended Sealing Points

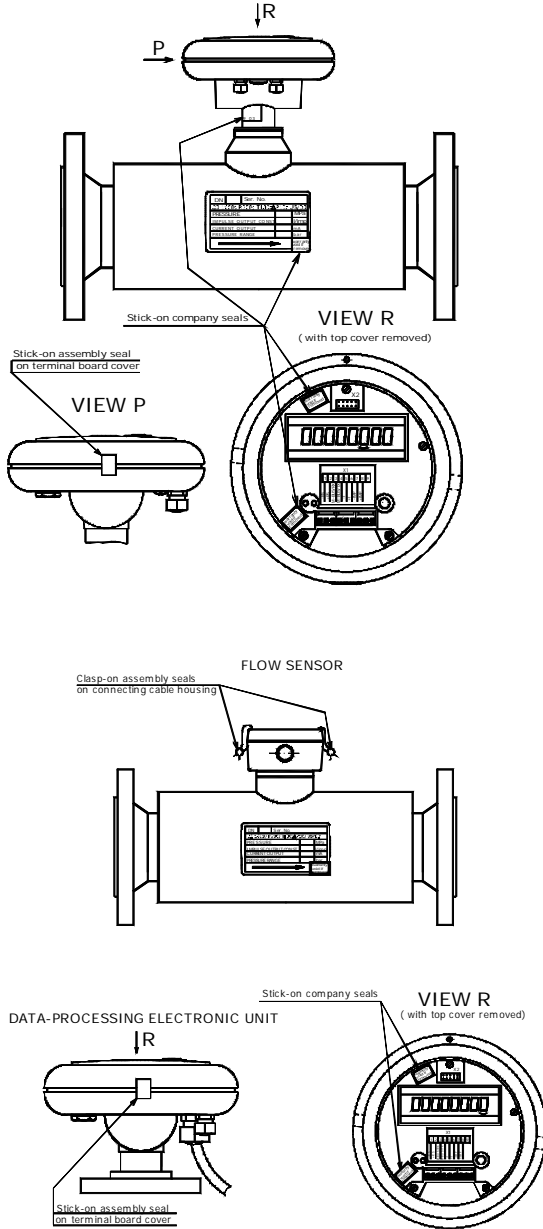

16 Installation

This page intentionally left blank.

5. Operation

5.1 Reading From the Meter Display

The 8-digit LCD displays either the flow rate in m^3/hour (or Gal/min), the total volume of the fluid since the last resetting, in m^3 (or in G), or the fluid pressure (if equipped with pressure sensor). The push-button is used to select desired measurement. The units of measure are indicated by the arrow symbol \blacktriangledown . Failure conditions are indicated with E1 through to E5.

The displayed values need to be multiplied by a coefficient from the table below.

The flow rate reading is delayed by about 6 seconds as the displayed rate is the arithmetic average of the last six measurements (each taken in 1-second intervals). The calculated values also appear at the meter outputs. The delay becomes noticeable with rapidly changing flow rate.

Due to the limited power capacity of the meter, the various display modes can only be selected in intervals of 1 second or longer. The push-button must be depressed for at least one second, and the next selection can be made after another 1 second or longer.

Depending on the total volume of fluid passed through the meter sensor and the associated coefficient, the decimal point on the display will move as shown in the following picture.

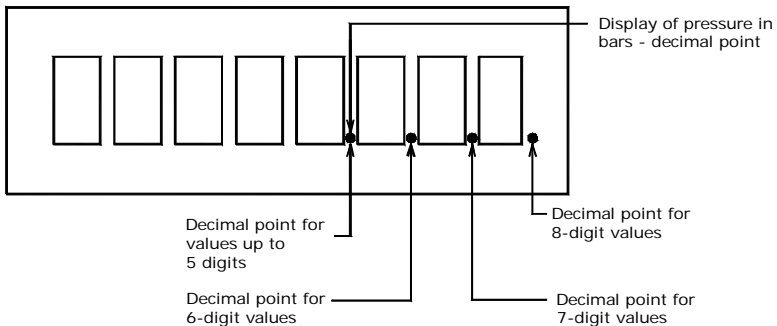

IMPORTANT NOTICE:

The displayed values and values recorded in archive need be multiplied by a coefficient given in the table below. The same coefficient is shown on the front panel under the metering units (m³ and m³/hour, or G and GPM).

Rated Inner Diameter DN		32	40	50	65	80	100	125	150	200	250	300
Coefficient	m ³ /hour	-	-	-	-	-	-	x 10	x 10	x 10	x 10	x 10
	m ³	-	-	-	-	-	-	x 10	x 10	x 10	x 10	x 10
	G/min	-	-	-	-	-	-	x 10	x 10	x 10	x 10	x 10
	G	x 10 ³	x 10 ³	x 10 ³	x 10 ³	x 10 ³	x 10 ³	x 10 ⁴	x 10 ⁴	x 10 ⁴	x 10 ⁴	x 10 ⁴

6. Communication

6.1 Communication Via Optical Interface

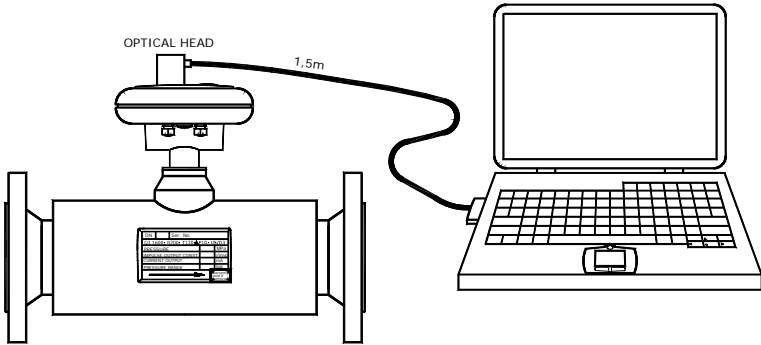

Communication via optical interface requires the optical probe with a 1.5m RS232 cable applied to a recess on the electronic unit box with the correct position defined by an arresting pin. The probe is held in place by a permanent magnet. The RS232 cable connects to a PC with the ArchTerm data-processing program installed.

Data available via optical interface:

- Reading measured data (flow rate, total volume and pressure)
at user-defined time intervals
- Storing of measured data
- Reading the parameters of the data archiving function
- Reading error messages generated and time when occurred
- Recording of maximum and minimum values and time
when occurred

The optical probe cable is supplied with an RS 232 connector and a separate RS232/USB converter. Optionally, the optical probe is supplied with USB connector. To activate the USB connection, a special controller needs to be installed on the PC (supplied with the probe).

6.2 Communication Via RS 232

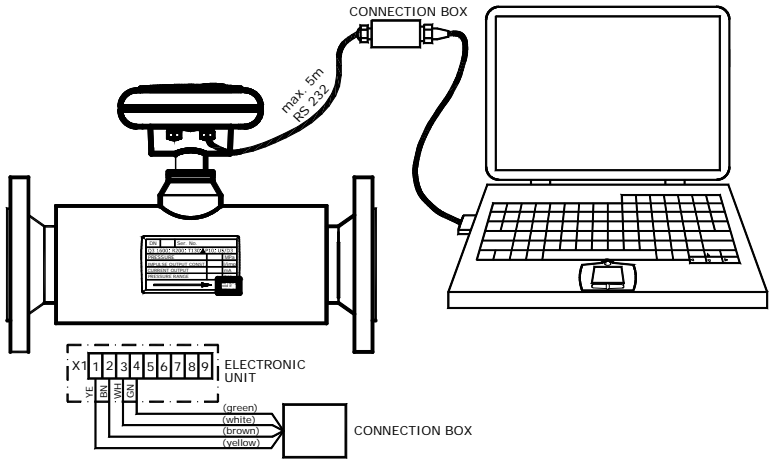

Serial RS 232 communication is available at terminals 1 to 4 (X1).
PC requires the ArchTerm data-processing program installed

Data available via RS232 port are the same as via optical interface.

6.3 Communication Via M-Bus

The M-Bus interface is available on terminals 3 and 4 (X1) and allows for reading flow rate and total volume. Note RS 232 port is not available when meter is configured for the M-Bus communication.

7. Error Functions

Meter errors will be identified as E1 through E5 by symbol ▼ shown at the bottom of the display unit.

E1 — The ultrasonic signal cannot freely propagate in the sensor cavity (due to the presence of air or mechanical particles)

E2 — Too great a difference between the signal travel times in and against the fluid flow direction (possibly due to the presence of air at one of the probes, which may be a temporary condition during the operation of filling the piping with fluid, or due to contamination of the face part of one of the probes)

E3 — A/D converter error (e.g. due to strong electromagnetic interference)

E4 — Flow rate in excess of q_s

E5 — Flat meter battery

Should the display go completely blank, check the battery condition (the voltage should be over 3V). Replace defective battery using the procedure described in Section 7.6. If meter still does not operate, contact supplier.

This page intentionally left blank.

8. Battery Life and Replacement

The battery lifetime in a meter of a standard configuration is 8 years, in a meter including various optional functions 6 years. The battery compartment is sealed to prevent unauthorized access.

While the battery is being replaced, all stored data including those on the total volume of fluid passed through the metering point are protected. The recommended battery brand is SAFT LITHIUM 3.6V/16Ah, type designation LS 33600.

Optionally, the electronic unit can be equipped with the smaller SAFT LITHIUM 3.6V /3.6Ah LSH 14 "light" battery containing less than 1g of lithium and provided with a plastic case ensuring correct fit in the battery holder. The lifetime of an LSH 14 "light" battery is 1 year since the production date and it can be at any time replaced by the standard 16Ah battery.

To replace the meter battery, first remove the plastic lid on the electronic unit box held in position by two M4 screws with hexagonal socket heads (use Allen wrench, size 2mm), then loosen three M3 bolts holding the electronic module in the aluminium box and pull the module outside the box. While doing that, make sure you do not damage any metrological or company seals. The electronic module can be pulled out as far as the probe conductors and output signal cables permit. The battery is located in a holder at the bottom of the unit; pull the old battery out and replace it with a new one. Mind the correct polarity as indicated on a plate on the battery holder. Push the electronic module back into the box, tighten the holding bolts, replace the box lid, fix its position with screws and apply assembly seal on one of them.

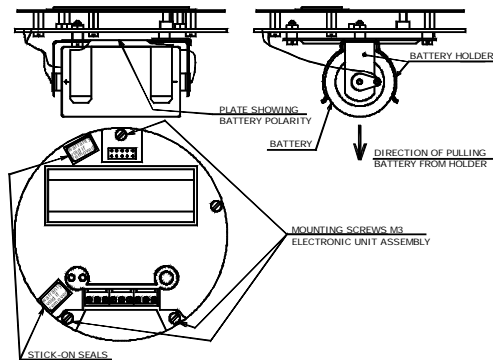

The electronic module removed from its box.

This page intentionally left blank.