

ACC-32

SIGNAL CONDITIONER

(DC Powered Version)

USER'S MANUAL



HP-248
September 2004

H **HOFFER FLOW CONTROLS, INC.**
The Turbine Flowmeter Company

107 Kitty Hawk Lane, P.O. Box 2145, Elizabeth City, NC 27906-2145
800-628-4584 252-331-1997 FAX 252-331-2886
www.hofferflow.com E-mail: info@hofferflow.com

Notice

HOFFER FLOW CONTROLS, INC. MAKES NO WARRANTY OF ANY KIND WITH REGARD TO THIS MATERIAL, INCLUDING, BUT NOT LIMITED TO, THE IMPLIED WARRANTIES OF MERCHANTABILITY AND FITNESS FOR A PARTICULAR PURPOSE.

This manual has been provided as an aid in installing, connecting, calibrating, operating, and servicing this unit. Every precaution for accuracy has been taken in the preparation of this manual; however, HOFFER FLOW CONTROLS, INC. neither assumes responsibility for any omissions or errors that may appear nor assumes liability for any damages that may result from the use of the products in accordance with information contained in the manual.

HOFFER FLOW CONTROLS' policy is to provide a user manual for each item supplied. Therefore, all applicable user manuals should be examined before attempting to install or otherwise connect a number of related subsystems.

During installation, care must be taken to select the correct interconnecting wiring drawing. The choice of an incorrect connection drawing may result in damage to the system and/or one of the components.

Please review the complete model number of each item to be connected and locate the appropriate manual(s) and/or drawing(s). Identify all model numbers exactly before making any connections. A number of options and accessories may be added to the main instrument, which are not shown on the basic user wiring. Consult the appropriate option or accessory user manual before connecting it to the system. In many cases, a system wiring drawing is available and may be requested from HOFFER FLOW CONTROLS.

This document contains proprietary information, which is protected by copyright. All rights are reserved. No part of this document may be photocopied, reproduced, or translated to another language without the prior written consent of HOFFER FLOW CONTROLS, INC.

HOFFER FLOW CONTROLS' policy is to make running changes, not model changes, whenever an improvement is possible. This affords our customers the latest in technology and engineering. The information contained in this document is subject to change without notice.

RETURN REQUESTS / INQUIRIES

Direct all warranty and repair requests/inquiries to the Hoffer Flow Controls Customer Service Department, telephone number (252) 331-1997 or 1-800-628-4584. BEFORE RETURNING ANY PRODUCT(S) TO HOFFER FLOW CONTROLS, PURCHASER MUST OBTAIN A RETURNED MATERIAL AUTHORIZATION (RMA) NUMBER FROM HOFFER FLOW CONTROLS' CUSTOMER SERVICE DEPARTMENT (IN ORDER TO AVOID PROCESSING DELAYS). The assigned RMA number should then be marked on the outside of the return package and on any correspondence.

FOR **WARRANTY** RETURNS, please have the following information available BEFORE contacting HOFFER FLOW CONTROLS:

1. P.O. number under which the product was PURCHASED,
2. Model and serial number of the product under warranty, and
3. Repair instructions and/or specific problems relative to the product.

FOR **NON-WARRANTY** REPAIRS OR **CALIBRATIONS**, consult HOFFER FLOW CONTROLS for current repair/calibration charges. Have the following information available BEFORE contacting HOFFER FLOW CONTROLS:

1. P.O. number to cover the COST of the repair/calibration,
2. Model and serial number of the product, and
3. Repair instructions and/or specific problems relative to the product.

LIMITED WARRANTY

HOFFER FLOW CONTROLS, INC. ("HFC") warrants HFC's products ("goods") described in the specifications incorporated in this manual to be free from defects in material and workmanship under normal use and service, but only if such goods have been properly selected for the service intended, properly installed and properly operated and maintained. This warranty shall extend for a period of (1) year from the date of delivery to the original purchaser (or eighteen (18) months if the delivery to the original purchaser occurred outside the continental United States). This warranty is extended only to the original purchaser ("Purchaser"). *Purchaser's sole and exclusive remedy is the repair and/or replacement of nonconforming goods as provided in the following paragraphs.*

In the event Purchaser believes the goods are defective, the goods must be returned to HFC, transportation prepaid by Purchaser, within twelve (12) months after delivery of goods (or eighteen (18) months for goods delivered outside the continental United States) for inspection by HFC. If HFC's inspection determines that the workmanship or materials are defective, the goods will be either repaired or replaced, at HFC's sole determination, free of additional charge, and the goods will be returned, transportation paid by HFC, using the lowest cost transportation available.

Prior to returning the goods to HFC, Purchaser must obtain a Returned Material Authorization (RMA) Number from HFC's Customer Service Department within 30 days after discovery of a purported breach of warranty, but no later than the warranty period; otherwise, such claims shall be deemed waived. See the Return Requests/Inquiries Section of this manual.

If HFC's inspection reveals the goods are free of defects in material and workmanship or such inspection reveals the goods were improperly used, improperly installed, and/or improperly selected for service intended, HFC will notify the purchaser in writing and will deliver the goods back to purchaser upon (i) receipt of Purchaser's written instructions and (ii) the cost of transportation. If Purchaser does not respond within 30 days after notice from HFC, the goods will be disposed of in HFC's discretion.

HFC does not warrant these goods to meet the requirements of any safety code of any state, municipality, or any other jurisdiction, and purchaser assumes all risk and liability whatsoever resulting from the use thereof, whether used singly or in combination with other machines or apparatus.

This warranty shall not apply to any HFC goods or parts thereof, which have been repaired outside HFC's factory or altered in any way, or have been subject to misuse, negligence, or accident, or have not been operated in accordance with HFC's printed instructions or have been operated under conditions more severe than, or otherwise exceeding, those set forth in the specifications for such goods.

THIS WARRANTY IS EXPRESSLY IN LIEU OF ALL OTHER WARRANTIES, EXPRESSED OR IMPLIED, INCLUDING ANY IMPLIED WARRANTY OF MERCHANTABILITY OR FITNESS FOR A PARTICULAR PURPOSE. HFC SHALL NOT BE LIABLE FOR ANY LOSS OR DAMAGE RESULTING, DIRECTLY OR INDIRECTLY, FROM THE USE OF LOSS OF USE OF THE GOODS. WITHOUT LIMITING THE GENERALITY OF THE FOREGOING, THIS EXCLUSION FROM LIABILITY EMBRACES THE PURCHASER'S EXPENSES FOR DOWNTIME, DAMAGES FOR WHICH THE PURCHASER MAY BE LIABLE TO OTHER PERSONS, DAMAGES TO PROPERTY, AND INJURY TO OR DEATH OF ANY PERSON. HFC NEITHER ASSUMES NOR AUTHORIZES ANY PERSON TO ASSUME FOR IT ANY OTHER LIABILITY IN CONNECTION WITH THE SALE OR USE OF HFC'S GOODS, AND THERE ARE NO AGREEMENTS OR WARRANTIES COLLATERAL TO OR AFFECTING THE AGREEMENT. *PURCHASER'S SOLE AND EXCLUSIVE REMEDY IS THE REPAIR AND/OR REPLACEMENT OF NONCONFORMING GOODS AS PROVIDED IN THE PRECEDING PARAGRAPHS. HFC SHALL NOT BE LIABLE FOR ANY OTHER DAMAGES WHATSOEVER INCLUDING INDIRECT, INCIDENTAL, OR CONSEQUENTIAL DAMAGES.*

Disclaimer:

Specifications are subject to change without notice.
Some pages are left intentionally blank.

TABLE OF CONTENTS

SECTION I
INTRODUCTION AND SPECIFICATIONS.....1.1

SECTION II
INSTALLATION2.1

SECTION III
CALIBRATION3.1

SECTION IV
OPERATION4.1

SECTION V
MAINTENANCE AND SCHEMATIC5.1

SECTION I

ACC-32 MODULATED CARRIER CONDITIONER/VOLTAGE CONVERTER

The ACC-32 Modulated Carrier Conditioner/Converter is an active pickoff accessory for the turbine flowmeter which provides a pulse output and an analog voltage output proportional to flowrate.

The Modulated Carrier principle eliminates the pickoff drag, associated with conventional magnetic pickoffs, resulting in a significant increase in the usable range of a turbine flowmeter at lower rates.

The ACC-32 excites a series MCP pickup mounted on the turbine flowmeter. Sensed through the flowmeter body, the motion of the turbine rotor modulates the coil field, subsequent conditioning provides a pulse output signal where each pulse is representative of a discrete volume of fluid and where the frequency is proportional to flowrate. Pulse scaling is optionally available to reduce output pulse rate where required.

The analog output is generated by passing the pulse output frequency signal to a frequency to the voltage converter to generate a voltage proportional to flowrate.

Flowmeters compatible with the ACC-32 are available in nominal sizes below two inches. Larger flowmeters do not require a modulated carrier pickup.

SPECIFICATIONS

INPUT	Pickup Type - Compatible with Series MCP pickoff. Transmission distance dependent on output waveform and drive requirements. Cable type Beldon 8422. Modulation frequency range 10 Hz - 3500 Hz.
PULSE OUTPUT (Square Waveform)	Open collector VMOS transistor 2N6660. Maximum OFF state voltage 60 VDC. Maximum ON current 1.0 amps. TTL/CMOS fanout of 10 TTL/CMOS loads. AC capacitively coupled square wave.
PULSE SCALING CAPABILITY (OPTIONAL)	÷2, ÷4, ÷8, ÷16, ÷32, ÷64, ÷128, ÷256

ORDERING INFORMATION

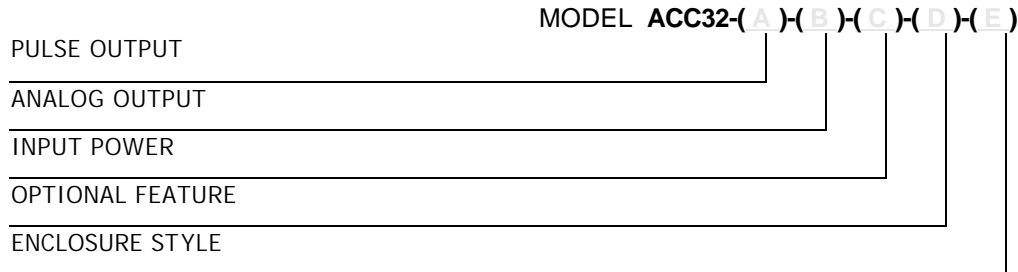

PULSE OUTPUT

MODEL ACC32-(A)-()-()-()-()

OPTION (A)

- (1) OPEN COLLECTOR
- (2) (2) TTL/CMOS
- (3) AC SQUARE WAVE
- (5) 0-10 V SQUARE WAVE

ANALOG OUTPUT

MODEL ACC32-()-(B)-()-()-()

OPTION (B)

- (X) NONE
- (C) 4-20 MA

INPUT POWER

MODEL ACC32-()-()-(C)-()-()

OPTION (C)

- (A) 115 VAC 50/60 HZ
- (B) 220 VAC 50/60 HZ
- (D) 15-35 VDC

OPTIONAL FEATURE

MODEL ACC32-()-()-()-(D)-()

OPTION (D)

- (PS) DIP SWITCH SELECTABLE
DIVIDE BY 2,4,8,16,32,64,128, 256

ENCLOSURE STYLE

MODEL ACC32-()-()-()-()-(E)

OPTION (E)

- (2) STYLE 2 CASE, GENERAL PURPOSE
- (4/O) STYLE 4 CASE, EXPLOSION-PROOF WITH WATER TIGHT 'O' RING
MEETS CLASS I, GROUP C, D (ADALET CASE, XJS WITH FLAT COVER), STOCK #200-0698
CLASS II, GROUPS E, F & G
CLASS III

NOTE: INSERT (X) IN MODEL NUMBER FOR EVERY OPTION NOT SPECIFIED.

SECTION II

FLOWMETER INSTALLATION

GENERAL

Proper application of the turbine flowmeter requires a suitable piping installation in order to achieve accurate and reliable operation.

The piping configuration immediately preceding and following the flowmeter is termed the meter run. Refer to the manufacturer's outline and installation instructions when installing the flowmeter and meter run.

RELATIVE - The performance of the turbine flowmeter is affected by the fluid swirl and non-uniform velocity profiles. The following recommendation will reduce such flow irregularities.

It is advisable not to locate the meter run immediately downstream of pumps, partially opened valves, bends or other similar piping configurations. In addition, the area surrounding the flowmeter should be free of sources of electrical noise such as motors, solenoids, transformers and power lines which may be coupled to the pickoff device.

The metering section should not be subjected to excessive vibration or shock. Such a condition may result in a mechanically induced output signal from the pickoff device.

METER RUN - In general, the meter run should be chosen to have the same inner diameter as the meter bore. A minimum of 10 pipe diameters of straight pipe upstream and 5 pipe diameters downstream are required. Where this optimum line configuration can not be implemented, it is advisable to install a flow straightener properly positioned upstream of the flowmeter. Orientation is not a critical factor, however, horizontal is a preferred orientation.

BYPASS RUN - A properly sized bypass run with suitable blocking valves may be equipped where an interruption in fluid flow for turbine meters servicing can not be tolerated.

STRAINER - A strainer, filter and/or air eliminator is recommended to reduce the potential of fouling or damage. See table for recommended mesh size.

On initial startup of a line, it is advisable to install a spool piece purging the line to eliminate damaging the flowmeter, due to flux, tape, solder, welds or other contaminants carried along by the fluid stream.

CAVITATION - Cavitation causes measurement inaccuracies in turbine flowmeter and should be avoided by suitable line and operating configurations.

Whenever the pressure within a pipeline instantaneously falls below the equilibrium vapor pressure of the fluid, a portion of the fluid vaporizes and forms bubbles in the pipeline. This is termed cavitation. Cavitation is eliminated by maintaining adequate back pressure on the flowmeter. A downstream valve that provides the necessary back pressure is one means for preventing cavitation in the metering run. Control valves should be located downstream, if possible. Some installations may also make use of a vapor eliminator upstream of the flowmeter.

The minimum required back pressure may be estimated using the following equation:

$$\text{Min: Back Pressure} = 1.25 \times \text{Vapor Pressure} + 2 \times \text{Pressure Drop}$$

INSTALLATION WIRING LAYOUT FOR INTERCONNECTIONS USING MCP PICKUP

In considering the interconnection between the flowmeter and the flow measurement system some attention must be given to anticipated noise sources and to the coupling of these noise sources to the interconnecting wiring.

Noise signals may be coupled inductively or capacitively into the wiring between the flowmeter and the electronic measuring systems. In general, utilizing a shielded, twisted pair for the interconnection greatly reduces this coupling. The shield should be grounded on one end of the cable only. In general, grounding only on the electronic measuring system is best.

However, even with proper interconnecting cabling crosstalk with other signal lines or power lines may still occur and should be avoided. Physical isolation in the manner in which the wiring is run reduces the chances of potential problems.

The turbine flowmeter equipped with a Modulated Carrier Pickup (MCP) should not be located more than 100 feet from the Modulated Carrier Conditioner. It is recommended that the Modulated Carrier Conditioner be installed on or near the flowmeter to assure proper operation. Enclosures suitable for mounting in hazardous and wet areas are available.

INSTALLATION OF ACC-32 (DC POWERED)

The Model ACC-32 should be placed in a convenient location which maintains access to the unit should repairs or readjustment be required.

Refer to outline and installation drawing for the appropriate case type to be installed. Drill appropriate mounting holes as required.

Refer to wiring installation drawing for the appropriate terminals for interconnections. Connections to the terminal block should be carefully dressed to avoid having bare wires extend past the screw clamp on the terminal block. Wires should be neatly dressed near bottom of enclosure to assure wiring will not become fouled when cover is installed.

Connect two conductor shielded cables from flowmeter. Connect shield to ACC-32 only.

The DC power connection should be made through a circuit breaker so that power can be turned off while servicing accessory model. The input power type is factory wired **15-35 VDC** based on the model number specified. An earth ground connection is also required.

Connect pulse output is used, several output pulse waveforms are available factory equipped. Wire to appropriate terminal for waveform desired and specified.

If the analog output has been equipped connect wiring to appropriate terminals and load. A shielded, twisted pair wire is recommended. Ground shield on one end only. Use some precautions as described for flowmeter input signal.

NOTES:
 1. FACTORY RECOMMENDS 10" PIPE DIA. UPSTREAM AND 5 PIPE DIA. DOWNSTREAM OF SAME SIZE PIPE AS FLOWMETER. A FLOW STRAIGHTENER IS RECOMMENDED IF THIS IS NOT POSSIBLE OR FOR CUSTODY TRANSFER APPLICATIONS.

REVISIONS			
REV	DESCRIPTION	DATE	APP
A	REDRAWN	1-31-92	
B	ADDED NOTE 2, CHG'D MESH SIZE	3-17-92	
C	DRAWING NO. WAS INSTL-104.	950907	<i>js</i>

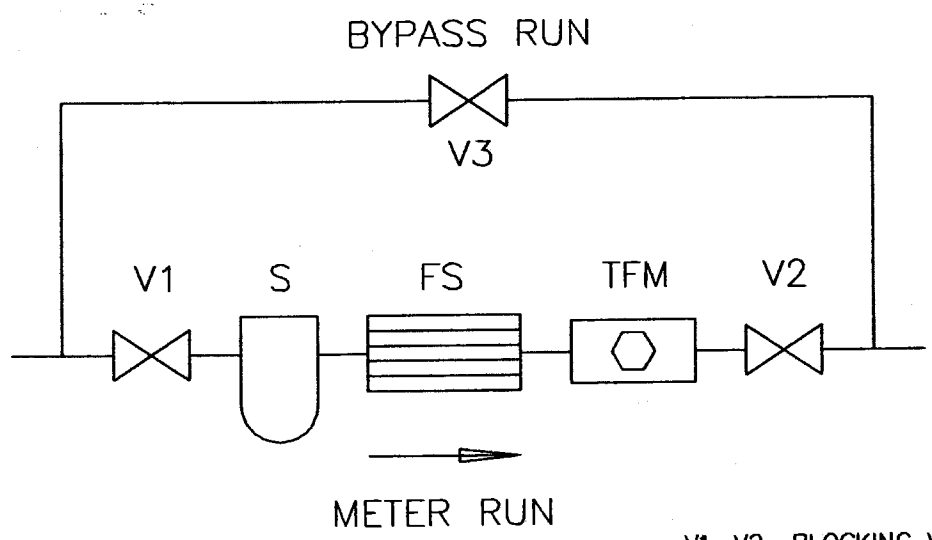

- V1, V2 BLOCKING VALVE
- S STRAINER
- FS FLOW STRAIGHTENER
- TFM TURBINE FLOWMETER
- V3 BYPASS VALVE

METER SIZE	MESH SIZE
MF SERIES	100
1/4" - 1/2"	100
5/8" - 1 1/4"	70
1 1/2" - 3"	40
4" - 12"	24

REPLACES INSTL-104

		MATERIAL	DRAWN DW	DATE 1-31-92	HOFFER FLOW CONTROLS, INC. ELIZABETH CITY, NC 27909
			CHECK JD	DATE 1-31-92	
			QA H. COVELL	DATE 1-31-92	
		FINISH	PROJ ENG KRH	DATE 1-31-92	
					TITLE
					TYPICAL TURBINE INSTALLATION
					SIZE
					CAGE CODE
					DWG NO
					REV
					A 33321 500-0194 C
					SCALE
					NONE
					SHEET 1 OF 1

CONFIDENTIAL PROPERTY OF HOFFER FLOW CONTROLS, INC. (HFC) NOT TO BE DISCLOSED TO OTHERS, REPRODUCED, OR USED FOR ANY OTHER PURPOSE, EXCEPT AS AUTHORIZED IN WRITING BY HFC. MUST BE RETURNED ON DEMAND, ON COMPLETION OF ORDER OR OTHER PURPOSE FOR WHICH LENT.

UNLESS OTHERWISE SPECIFIED DIMENSIONS ARE IN INCHES TOLERANCES OTHER THAN RAW MATERIAL SHALL BE HELD AS FOLLOWS:
 2 PLACE DECIMAL ±.01
 3 PLACE DECIMAL ±.005
 FRACTIONAL ±1/64
 ANGULAR ±1/2°

NOTES:

1. * EQUIPPED FOR ANALOG OUTPUT OPTION.
2. UNIT MAY BE INSTALLED IN EXPLOSION PROOF ENCLOSURE.

REVISIONS

REV	DESCRIPTION	DATE	APP
A	REVISED AND REDRAWN. (CS)	920930	JD
B	DWG NO. WAS ACC32-401. (CS)	951117	JD
C	DWG NO. WAS 500-0283	000627	<i>CS</i>

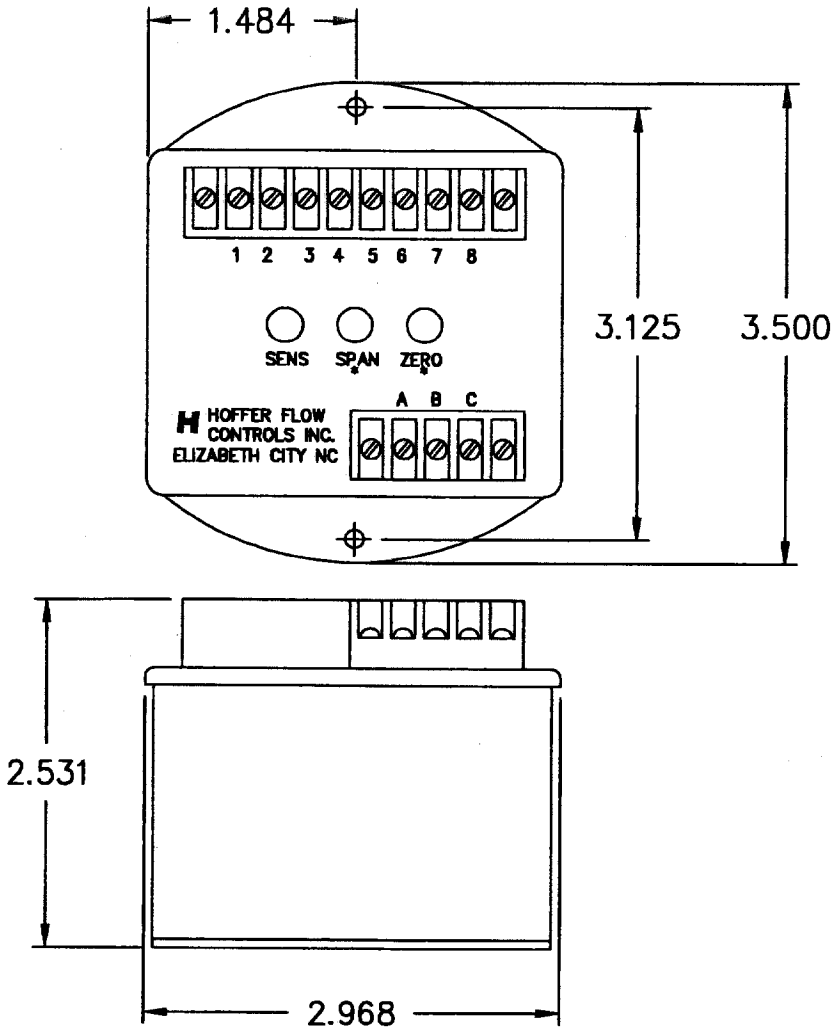

REPLACES 500-0283

		MATERIAL	CONTRACT/JN		 HOFFER FLOW CONTROLS, INC. ELIZABETH CITY, NC 27909								
			DRAWN	DATE									
			J.F.	9/82									
		FINISH	CHECK	11/82									
			R.S.		TITLE OUTLINE OF ACC32								
			QA										
			PROJ ENG										
		CONFIDENTIAL PROPERTY OF HOFFER FLOW CONTROLS, INC. (HFC) NOT TO BE DISCLOSED TO OTHERS, REPRODUCED, OR USED FOR ANY OTHER PURPOSE, EXCEPT AS AUTHORIZED IN WRITING BY HFC. MUST BE RETURNED ON DEMAND, ON COMPLETION OF ORDER OR OTHER PURPOSE FOR WHICH LENT.	UNLESS OTHERWISE SPECIFIED DIMENSIONS ARE IN INCHES TOLERANCES OTHER THAN RAW MATERIAL SHALL BE HELD AS FOLLOWS:		<table border="1"> <tr> <td>SIZE</td> <td>FSCM NO</td> <td>DWG NO</td> <td>REV</td> </tr> <tr> <td>A</td> <td>33321</td> <td>ACC32-401</td> <td>C</td> </tr> </table>	SIZE	FSCM NO	DWG NO	REV	A	33321	ACC32-401	C
SIZE	FSCM NO		DWG NO	REV									
A	33321	ACC32-401	C										
NEXT ASSY	USED ON		2 PLACE DECIMAL ±.01 3 PLACE DECIMAL ±.005 FRACTIONAL ±1/64 ANGULAR ±1/2°		<table border="1"> <tr> <td>SCALE</td> <td>SHEET</td> </tr> <tr> <td>NONE</td> <td>1 OF 1</td> </tr> </table>	SCALE	SHEET	NONE	1 OF 1				
SCALE	SHEET												
NONE	1 OF 1												
APPLICATION													

NOTES:

1. WIRE TO 7 OR 8 DEPENDING ON TYPE OF OUTPUT WAVEFORM AND SPECIFIED.
2. EITHER DC POWER + OR DC POWER RETURN - MUST BE CONNECTED TO CASE GROUND.

REVISIONS

REV	DESCRIPTION	DATE	APP
A	NOTE 2 (JD)	8/89	
B	REVISED AND REDRAWN. (CS)	920929	JD
C	DWG NO WAS ACC32-702 (CS)	951120	JD
D	DWG NO WAS 700-0116	000627	<i>EJB</i>

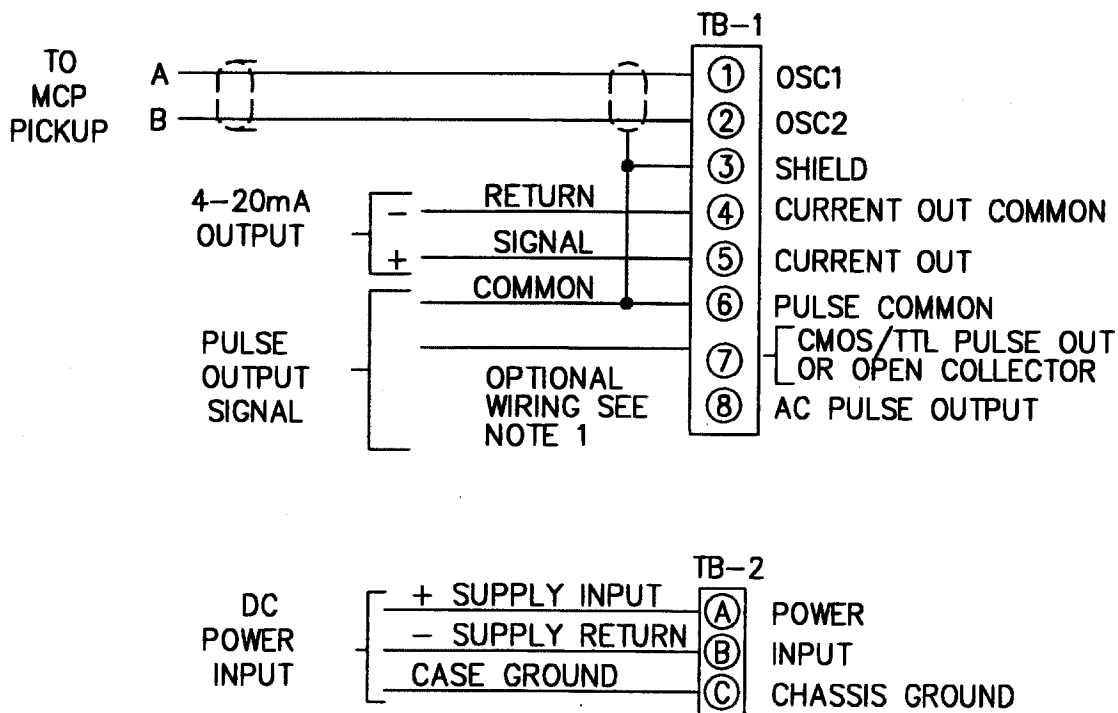

REPLACES 700-0116

		MATERIAL	CONTRACT/JN		 HOFFER FLOW CONTROLS, INC. ELIZABETH CITY, NC 27909	
			DRAWN RS	DATE 11/82		
			CHECK JD	11/82		
		FINISH	QA			
			PROJ ENG KH	11/82	TITLE WIRING, INSTALLATION— ACC32 (DC)	
		CONFIDENTIAL PROPERTY OF HOFFER FLOW CONTROLS, INC. (HFC) NOT TO BE DISCLOSED TO OTHERS, REPRODUCED, OR USED FOR ANY OTHER PURPOSE, EXCEPT AS AUTHORIZED IN WRITING BY HFC. MUST BE RETURNED ON DEMAND, ON COMPLETION OF ORDER OR OTHER PURPOSE FOR WHICH LENT.	UNLESS OTHERWISE SPECIFIED DIMENSIONS ARE IN INCHES TOLERANCES OTHER THAN RAW MATERIAL SHALL BE HELD AS FOLLOWS: 2 PLACE DECIMAL ±.01 3 PLACE DECIMAL ±.005 FRACTIONAL ±1/64 ANGULAR ±1/2°			
NEXT ASSY	USED ON		SIZE A	FSCM NO 33321	DWG NO ACC32-702	REV D
APPLICATION			SCALE NONE		SHEET 1 OF 1	

NOTES:

1. DC POWER SUPPLY +15 (MIN) TO +35VDC (ABSOLUTE MAX).

2. WIRE PULSE OUTPUT AS FOLLOWS:

MODEL	TERMINAL WIRING	PULSE OUTPUT
ACC32-1-()-D-()-()	6 AND 7	O.C.
ACC32-2-()-D-()-()	6 AND 7	TTL/CMOS
ACC32-3-()-D-()-()	6 AND 8	AC SQUARE

3. TERMINAL BLOCK ACCEPTS WIRE LEADS.

REVISIONS

REV	DESCRIPTION	DATE	APP
A	REVISED AND REDRAWN. (CS)	920929	JD
B	DWG NO WAS ACC32-703 (CS)	951117	JD
C	DWG NO WAS 700-0114	000627	ES
D	CORRECTED TB-2, A,B,C WAS 1,2,3	030624	V.K

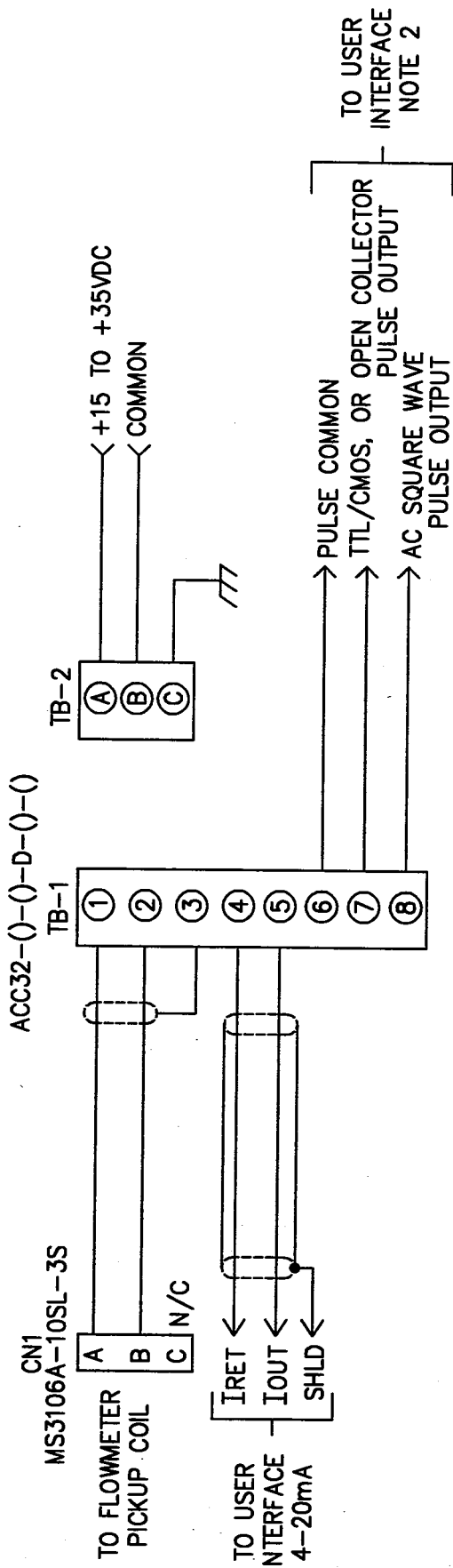

REPLACES 700-0114

		CONTRACT/JN DRAWN J.D. CHECK QA PROJ ENG K.HOFFER 8/90	
		DATE 8/90	
MATERIAL		FINISH	
NEXT ASSY		USED ON	
APPLICATION		UNLESS OTHERWISE SPECIFIED DIMENSIONS ARE IN INCHES, TOLERANCES OTHER THAN THE SIZE OF RAW MATERIAL, SHALL BE HELD AS FOLLOWS: 2 PLACE DECIMAL ±.01 3 PLACE DECIMAL ±.005 FRACTIONAL ANGULAR ±1/2°	
TITLE WIRING, INSTALLATION - MODEL ACC32-()-D-()-() 15-35VDC		SIZE/FSCM NO DWG NO A 33321 ACC32-703 D REV	
HOFFER FLOW CONTROLS, INC. ELIZABETH CITY, NC 27909		SCALE NONE SHEET 1 of 1	

CONFIDENTIAL PROPERTY OF HOFFER FLOW CONTROLS, INC. (HFC) NOT TO BE DISCLOSED TO OTHERS, REPRODUCED, OR USED FOR ANY OTHER PURPOSE, EXCEPT AS AUTHORIZED IN WRITING BY HFC. MUST BE RETURNED ON DEMAND, ON COMPLETION OF ORDER OR OTHER PURPOSE FOR WHICH LENT.

NOTES:

- ENCLOSURE MEETS:
CLASS I, GROUP C & D
CLASS II, GROUP E, F & G
NEMA 7 & 9
- USED WHEN SIGNAL CONDITIONER IS
ENCLOSED, MOUNTED OR REMOTE.

REVISIONS			
REV	DESCRIPTION	DATE	APP

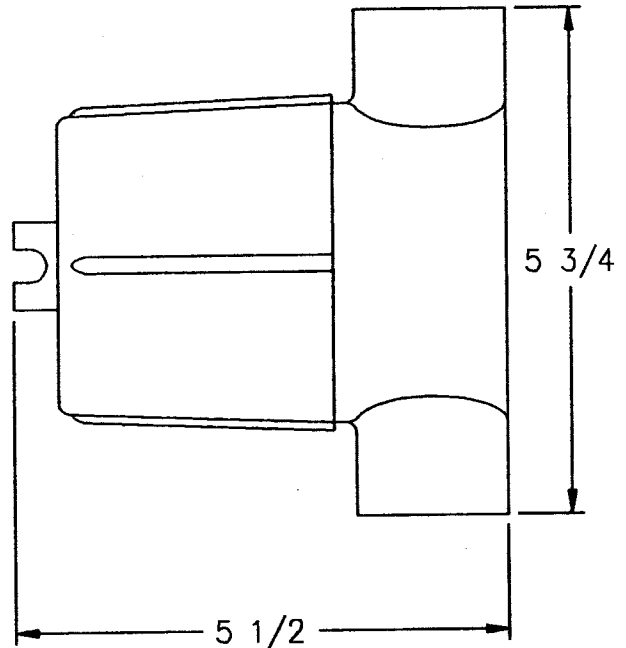
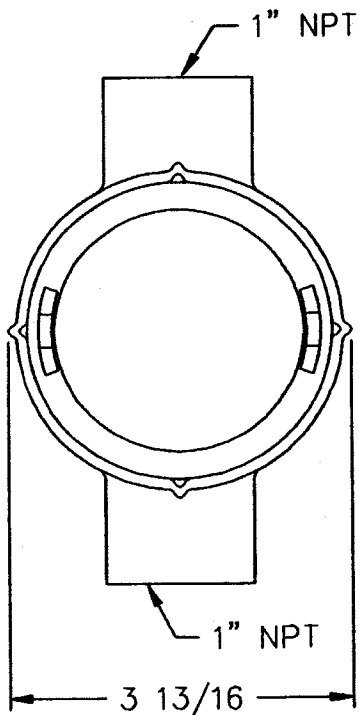

		MATERIAL	DRAWN <i>Sweet</i>	DATE <i>9/10/83</i>	H HOFFER FLOW CONTROLS, INC. ELIZABETH CITY, NC 27909
			CHECK		
			PROJ ENG <i>JA</i>	<i>9/10/83</i>	
		FINISH			TITLE ENCLOSURE, EXPLOSION PROOF- STYLE 3
		CONFIDENTIAL PROPERTY OF HOFFER FLOW CONTROLS, INC. (HFC) NOT TO BE DISCLOSED TO OTHERS, REPRODUCED, OR USED FOR ANY OTHER PURPOSE, EXCEPT AS AUTHORIZED IN WRITING BY HFC. MUST BE RETURNED ON DEMAND, ON COMPLETION OF ORDER OR OTHER PURPOSE FOR WHICH LENT.	UNLESS OTHERWISE SPECIFIED DIMENSIONS ARE IN INCHES TOLERANCES OTHER THAN RAW MATERIAL SHALL BE HELD AS FOLLOWS: 2 PLACE DECIMAL ±.01 3 PLACE DECIMAL ±.005 FRACTIONAL ±1/64 ANGULAR ±1/2°		SIZE CAGE CODE DWG NO REV A 33321 500-0018 -
NEXT ASSY	USED ON		APPLICATION	SCALE	NONE

NOTES:

ENCLOSURE MEETS:
 CLASS I, GROUPS C & D
 CLASS II, GROUPS E, F & G
 NEMA 7 & 9

REVISIONS			
REV	DESCRIPTION	DATE	APP

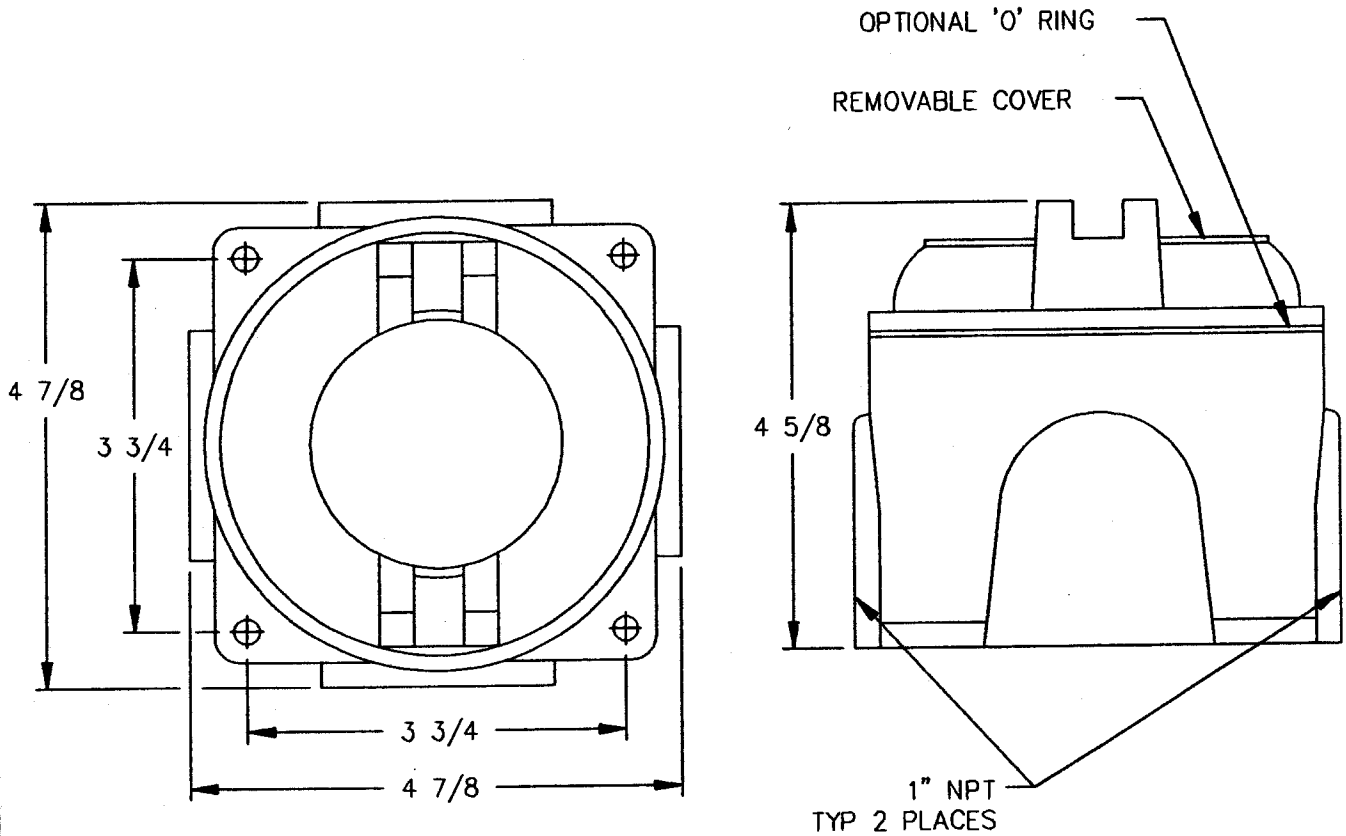

		MATERIAL	DRAWN <i>Sweet</i>	DATE 9/4/83	H HOFFER FLOW CONTROLS, INC. ELIZABETH CITY, NC 27909			
			CHECK					
		FINISH	PROJ ENGR <i>A</i>	9/1/83	TITLE			
					ENCLOSURE, EXPLOSION PROOF- STYLE 4			
NEXT ASSY	USED ON	CONFIDENTIAL PROPERTY OF HOFFER FLOW CONTROLS, INC. (HFC) NOT TO BE DISCLOSED TO OTHERS, REPRODUCED, OR USED FOR ANY OTHER PURPOSE, EXCEPT AS AUTHORIZED IN WRITING BY HFC. MUST BE RETURNED ON DEMAND, ON COMPLETION OF ORDER OR OTHER PURPOSE FOR WHICH LENT.	UNLESS OTHERWISE SPECIFIED DIMENSIONS ARE IN INCHES TOLERANCES OTHER THAN RAW MATERIAL SHALL BE HELD AS FOLLOWS:		SIZE	FSCM NO	DWG NO	REV
APPLICATION			2 PLACE DECIMAL ±.01 3 PLACE DECIMAL ±.005 FRACTIONAL ±1/64 ANGULAR ±1/2°	A	33321	500-0021	-	SCALE NONE

SECTION III

CALIBRATION OF ANALOG OUTPUT - GENERAL CONSIDERATIONS (LIQUID APPLICATIONS)

INTRODUCTION

In general, all flow measurement systems supplied by Hoffer Flow Controls have been factory calibrated as specified by the user, at the time of purchase, free of charge.

All systems which underwent such a factory calibration have a calibration card attached prior to shipment. This card contains the details of analog outputs, as well as other useful calibration data.

Field calibration is only required when a change has occurred or is sought to the measuring system. Such a change may be due to repair, replacement or recalibration of the flowmeter, or perhaps a change in the analog output span.

PROCEDURE

Begin by determining the equivalent maximum volumetric flowrate in GPM, expected by the application, term this GPM (MAX). GPM (MAX) may be calculated based on the analog output scale requirements or may be the maximum flowrate listed on the flowmeter's calibration sheet.

From the calibration constant (or K Factor) listed on the data sheet for the flowmeter, obtain the frequency corresponding to GPM (MAX) using Equation 1 and designate this frequency F (MAX).

Equation 1

$$F_{MAX} = \frac{K_{AVG} \times GPM_{MAX}}{60}$$

FOR ANALOG OPTION

The analog output of the ACC-32 may be calibrated with the aid of an external oscillator used in conjunction with a frequency counter.

The external oscillator is used to supply a test frequency. In this method, the external oscillator is connected to the signal input terminals as shown in Figure 1. The oscillator's output frequency is set to equal F (MAX) as indicated on the frequency counter.

1. The course range adjustment is accomplished by selecting a switch position on a DIP switch located on the PCA-58 printed circuit card. See Table A to determine required switch position and set into switch as shown on drawing ACC-32-403 for anticipated F MAX.

NOTE: *It is necessary to open the cover of the enclosure by removing two screws on the side of the box and lifting cover. Two printed circuit cards are attached. The “RANGE” Dip Switch may be programmed with a pen. Input power should be removed during this step.*

2. Connect a digital milliammeter or equivalent, across the voltage output terminals.
3. Adjust SPAN control fully counter clockwise or 20 turns.
4. Adjust ZERO control for desired zero current (i.e., 4 mA).
5. Inject the Test Frequency equal to F (MAX) while adjusting SPAN for current equal to 20 mA. See test setup shown in Figure 1.

NOTE: *Iterate steps 4 and 5 until no change is observed.*

Table A

F (MAX)	RANGE SELECT SWITCH POSITION
75 TO 150	1
150 TO 300	2
300 TO 600	3
600 TO 1200	4
1200 TO 2400	5



HOFFER FLOW CONTROLS, INC.

107 Kitty Hawk Lane, P.O. Box 2145, Elizabeth City, NC 27906
919-331-1997 800-628-4584 FAX 919-331-2886

Applications of ACC Series Signal Conditioner/Converters to Gas Measurement Applications under Fixed Temperature and Pressure.

General-

Hoffer's ACC Series of Signal Conditioner/Converters are often applied to gas metering applications. Where the analog output is to represent a mass flow rate or the equivalent amount of gas at reference conditions, special considerations need to be applied. These considerations are outlined in the following paragraphs.

Conversion to Volumetric Flow Rates-

Where an analog output span is to be setup as flowrate expressed in mass units or in equivalent flow of gas at a reference condition, a conversion to equivalent ACFM is necessary before the calibration and setup may be performed.

Begin by converting the given flowrate to SCFM units of measure at a reference condition of 70°F, and a pressure of 14.696 PSIA.

Next convert the assumed flowing pressure to units of PSIA, designate this FLOWING_P.

Next convert the assumed flowing temperature to units of Degrees Rankine, designate this FLOWING_T.

Next calculate the equivalent maximum flowrate under the assumed line pressure and temperature to find the equivalent ACFM using the equation which follows:

$$ACFM = SCFM \times \frac{14.696}{FLOWING_P} \times \frac{FLOWING_T}{530}$$

Finally, follow the setup procedure listed for the Signal Conditioner to determine the equivalent full scale frequency, Fmax for this application.

Follow the procedure listed in the User's Manual, and the calibration setup listed, to adjust the span and zero controls to achieve the desired analog span.

Note that the above procedure assumes the standard conditions to be 70°F and 14.696 PSIA, these vary reference conditions from industry to industry and from country to country. It is important that any variations of the reference conditions be considered in the setup of the instrument.

CALIBRATION OF ANALOG OUTPUT - GENERAL CONSIDERATIONS FOR GAS APPLICATIONS

INTRODUCTION

In general, all flow measurement systems supplied by Hoffer Flow Controls have been factory calibrated as specified by the user, at the time of purchase, free of charge.

All systems which underwent such a factory calibration have a calibration card attached prior to shipment. This card contains the details of analog outputs, as well as, other useful calibration data.

Field calibration is only required when a change has occurred or is sought to the measuring system. Such a change may be due to repair, replacement or recalibration of the flowmeter, or perhaps a change in the analog output span.

PROCEDURE

Begin by determining the equivalent maximum volumetric flow rate in ACFM, expected by the application, term this ACFM(MAX). ACFM(MAX) may be calculated based on the analog output scale requirements or may be the maximum flow rate listed on the flowmeter's calibration sheet.

From the calibration constant (or K-Factor) listed on the data sheet for the flowmeter, obtain the frequency corresponding to ACFM(MAX) using Equation-1 and designate this frequency F(MAX).

Equation-1

$$F_{MAX} = \frac{K_{AVG} \times ACFM_{MAX}}{60}$$

The analog output of the ACC-32 may be calibrated with the aid of an external oscillator used in conjunction with a frequency counter.

The external oscillator is used to supply a test frequency. In this method, the external oscillator is connected to the signal input terminals as shown in Figure-1. The oscillator's output frequency is set to equal F(MAX) as indicated on the frequency counter.

1. The course range adjustment is accomplished by selecting a switch position on a DIP switch located on the PCA-58 printed circuit card. See Table A to determine required switch position and set into switch as shown on drawing ACC-32-403 for anticipated F(MAX).

NOTE: It is necessary to open the cover of the enclosure by removing two screws on the side of the box and the lifting cover. Two printed circuit cards are attached. The "RANGE" Dip Switch may be programmed with a pen. Input power should be removed during this step.

NOTES:

1. USE TEST AMPLITUDE OF 100mv RMS OR LESS, SINUSOIDAL WAVE FORM.
2. REMOVE ALL OTHER INTERCONNECTIONS OTHER THAN THOSE SHOWN.
3. OBSERVE CAUTION WHEN PREFORMING CALIBRATION.
4. EITHER DC POWER INPUT + OR DC POWER RETURN - MUST BE CONNECTED TO CASE GROUND.

REVISIONS

REV	DESCRIPTION	DATE	APP
A	NOTE 4 (JD)	8/89	
B	REVISED AND REDRAWN. (CS)	920929	JD
C	DWG NO WAS ACC32-603 (CS)	951117	JD
D	DWG NO WAS 700-0112	000627	<i>Ee</i>

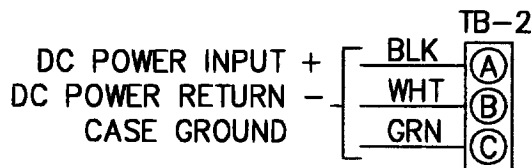
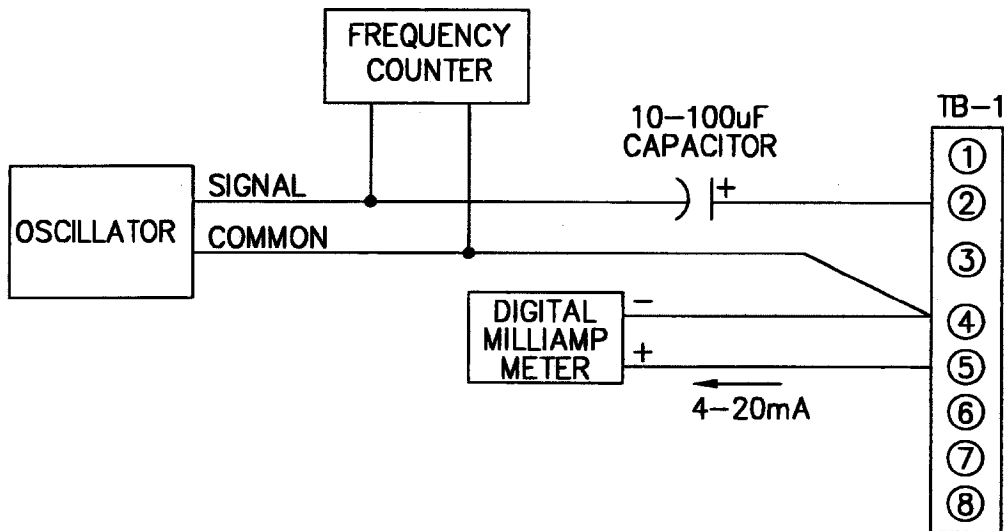

REPLACES 700-0112

		MATERIAL	CONTRACT/JN		 HOFFER FLOW CONTROLS, INC. ELIZABETH CITY, NC 27909	
			DRAWN RS	DATE 11/82		
			CHECK JD	11/82		
		FINISH	QA			
			PROJ ENG KH	11/82	TITLE CALIBRATION SETUP- FIGURE 1 (DC)	
		CONFIDENTIAL PROPERTY OF HOFFER FLOW CONTROLS, INC. (HFC) NOT TO BE DISCLOSED TO OTHERS, REPRODUCED, OR USED FOR ANY OTHER PURPOSE, EXCEPT AS AUTHORIZED IN WRITING BY HFC. MUST BE RETURNED ON DEMAND, ON COMPLETION OF ORDER OR OTHER PURPOSE FOR WHICH LENT.			UNLESS OTHERWISE SPECIFIED DIMENSIONS ARE IN INCHES TOLERANCES OTHER THAN RAW MATERIAL SHALL BE HELD AS FOLLOWS: 2 PLACE DECIMAL ±.01 3 PLACE DECIMAL ±.005 FRACTIONAL ±1/64 ANGULAR ±1/2°	
NEXT ASSY	USED ON		SIZE A	FSCM NO 33321	DWG NO ACC32-603	REV D
APPLICATION			SCALE NONE	SHEET 1 OF 1		

ZONE	REV	DESCRIPTION	DATE	APP
A		ADDED NOTE 1.	(JD) 2/84	
B		REVISED AND REDRAWN.	(CS) 920930	JD
C		DWG NO WAS ACC32-403.	(CS) 951117	JD
D		DWG NO WAS 500-0284.	000627	C

NOTES:
 1. FUSE AND TRANSFORMER ARE EQUIPPED FOR 110VAC POWER ONLY.

SERVICING PROCEDURES

TO REMOVE COVER/PRINTED CIRCUIT SUBASSEMBLY

- TURN POWER TO ACC32 OFF.
- REMOVE TWO MACHINE SCREWS FROM SIDES OF CASE
- LIFT COVER/PRINTED CARD ASSEMBLY OUT.

REPLACING FUSE

- REMOVE COVER/PRINTED CIRCUIT SUBASSEMBLY
- LOCATE FUSE ON SUBASSEMBLY
- PULL FUSE FROM SOCKET USING FINGERS (PLIERS ARE NOT RECOMMENDED)
- INSTALL NEW FUSE
- REASSEMBLE INTO LOWER CASE

RANGE SELECT FOR ANALOG OUTPUT

- REMOVE COVER/PRINTED CIRCUIT SUBASSEMBLY
- TURN 'ON' DESIRED RANGE POSITION USING A BALL POINT PEN OR SIMILAR OBJECT. SEE RANGE SELECT DETAIL.
- REASSEMBLE INTO LOWER CASE

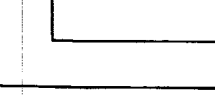

RANGE SELECT DETAIL

SWITCH 2 IS SHOWN DEPRESSED FOR ILLUSTRATION ONLY
 NOTE: SELECT ONE SWITCH ONLY. ALL OTHER SWITCHES MUST BE OFF.

TABLE 1

RANGE SELECT SWITCH	FOR F MAX
1	75-150
2	150-300
3	300-600
4	600-1200
5	1200-2400
6	NOTUSED

CONTRACTOR/DR		DATE	
DRWN	J.F.	12/78	12/78
CHKD	R.S.	12/78	12/78
QA			
PRD ENG	K.HOFFER	12/78	

ALL OTHERS ARE DELETED AND SHOULD BE REMOVED FROM THE DRAWING. THE SIZE OF ANY ORIGINAL SHALL BE THE SAME AS THE ORIGINAL.

3 PLACE REMAINS AS IS. PLACE REMAINS AS IS. PLACE REMAINS AS IS.

REPLACES 500-0284

H OFFER FLOW CONTROLS, INC.
 ELIZABETH CITY, NC

TITLE
 CONTROLS AND ADJUSTMENTS

SIZE C 33321 DWG NO ACC32-403 REV D

SCALE N/A SHEET 1 OF 1

SECTION IV

OPERATION

INITIAL STARTUP

Perform any purging of piping with spool piece in place. Once completed, install the flowmeter and connect cabling to pickup coil. If false counting action occurs turn sensitivity control counterclockwise.

INTRODUCTION

The pulse output and analog output commence with flow through the flowmeter.

For the analog output, the span is that established by either the factory calibration or field calibration. The range is 4-20 mA into a maximum of 375 ohms of loop resistance.

PRINCIPLE OF OPERATION

A simplified block diagram of the ACC-32 Modulated Carrier Conditioner/Converter is given on the drawing ACC-32-601. Key functional blocks, as well as, information flow are designated. The basic operation of the system is as follows.

The MCP on the turbine flowmeter is connected to the Model ACC-32 with a shielded twisted pair signal cable. The MCP pickup coil forms part of an oscillator circuit and is excited by the ACC-32. Motion of the turbine rotor modulates the oscillator output. A demodulator converts the AM signal to a signal at a frequency determined by the rotor speed. The low level demodulated signal is then passed through a signal conditioning chain where it is filtered, amplified and shaped into a train of digital pulses whose frequency is related to the volume flowrate and where each pulse represents a discrete volume of fluid.

ANALOG OUTPUT

The signal entering the frequency to analog converter is passed through a combination of a divide by N and a DIP switch MATRIX. The QN output is chosen whose pulse rate is between 75 and 150 Hz at the maximum flowrate to be measured. This scaled pulse rate is fed to a precision monostable circuit. The output of the monostable is then filtered into an analog voltage that is proportional to volumetric flowrate.

The output amplifier is a voltage to current amplifier. It offers zero and span available in a standard process range of 4 to 20 mA.

POWER SUPPLY

The power supply provides for operating bias voltage for all internal circuitry.

The output amplifier may be configured to provide one of the following:

1. High level AC square wave (Capacitively coupled).
2. Open collector transistor.
3. TTL/CMOS compatible square pulse of 5 volt amplitude.

The output amplifier is buffered from the signal driving the analog output.

REVISIONS

REV	DESCRIPTION	DATE	APP
A	REVISED AND REDRAWN. (CS)	920929	JD
B	DWG NO WAS ACC32-604 (CS)	951117	JD
C	DWG NO WAS 500-0286	000627	EO

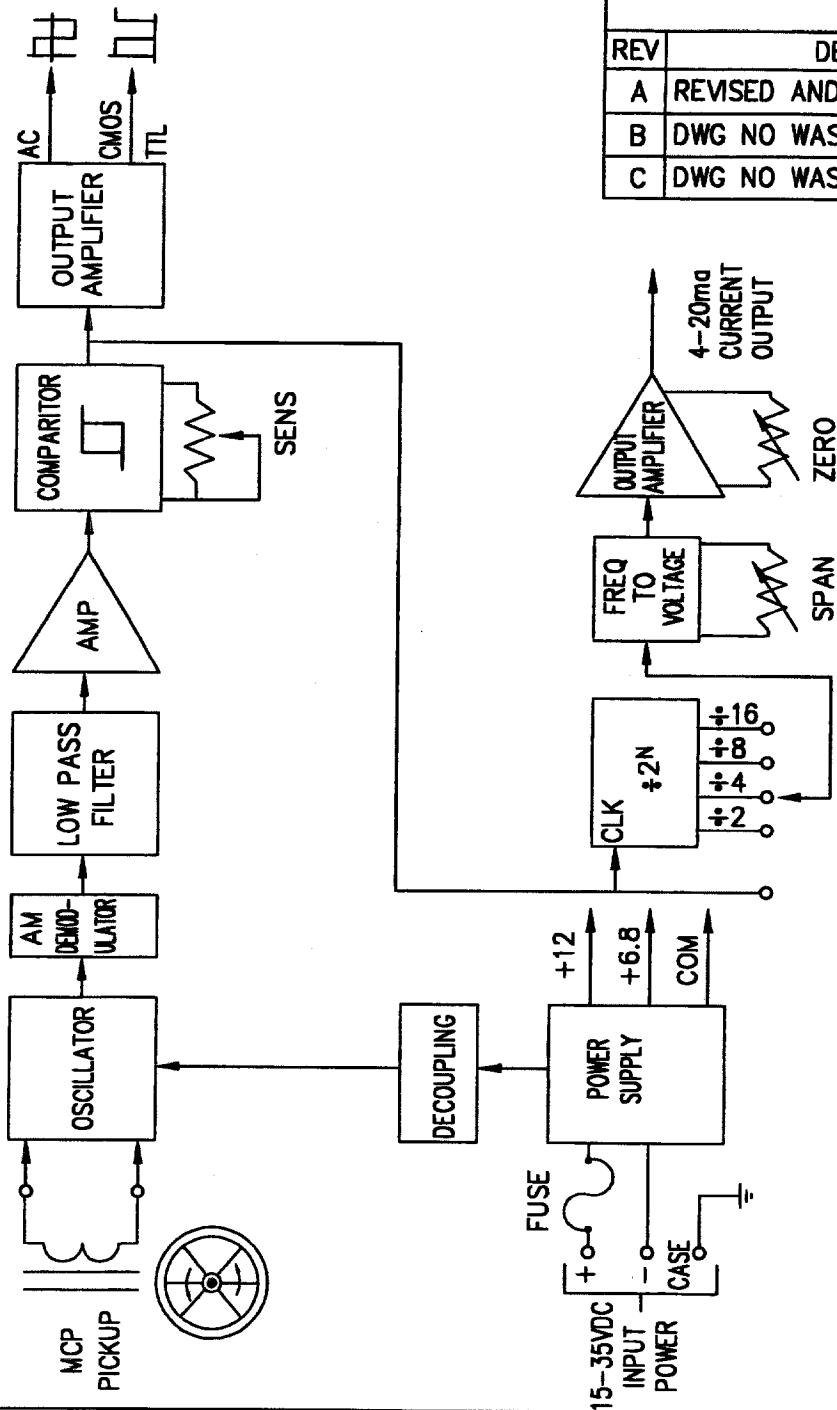

REPLACES 500-0286

MATERIAL		CONTRACT/JN		 HOFFER FLOW CONTROLS, INC. ELIZABETH CITY, NC 27909	
		DRAWN	DATE		
		RS	11/82		
		CHECK			
		JD	11/82	TITLE	
		QA		BLOCK DIAGRAM- ACC32 (DC)	
		PROJ ENG			
		KH	11/82		
CONFIDENTIAL PROPERTY OF HOFFER FLOW CONTROLS, INC. (HFC) NOT TO BE DISCLOSED TO OTHERS, REPRODUCED, OR USED FOR ANY OTHER PURPOSE, EXCEPT AS AUTHORIZED IN WRITING BY HFC. MUST BE RETURNED ON DEMAND, ON COMPLETION OF ORDER OR OTHER PURPOSE FOR WHICH LENT.		UNLESS OTHERWISE SPECIFIED DIMENSIONS ARE IN INCHES TOLERANCES OTHER THAN RAW MATERIAL SHALL BE HELD AS FOLLOWS: 2 PLACE DECIMAL ±.01 3 PLACE DECIMAL ±.005 FRACTIONAL ±1/64 ANGULAR ±1/2°			
NEXT ASSY	USED ON	SIZE	FSCM NO	DWG NO	REV
		A	33321	ACC32-604	C
APPLICATION		SCALE	SHEET 1 OF 1		
		NONE			

SECTION V

MAINTENANCE, GENERAL

Hoffer Flow Controls Flow Measurement Systems are constructed to give a long service life in the targeted measuring field and service environment. However, problems do occur from time to time and the following points should be considered for preventive maintenance and repairs.

The bearing type used in the flowmeter was chosen to give compromise between long life, chemical resistance, ease of maintenance and performance. A preventive maintenance schedule should be established to determine the amount of wear which has occurred since last overhaul. See user's manual for flowmeter for further instructions.

A spare parts list has been provided which at the discretion of the user, may be user stocked. Consult with the manufacturer if an abridged spare parts list is sought. The recommended spare parts list may be found following this section and in the user's manual for the flowmeter.

In case the flow measurement system malfunctions or becomes inoperative, a troubleshooting procedure is enclosed.

Factory consultation is available to assist in diagnosing problems. In addition, factory repair parts and service are available for individuals who wish to utilize this service.

A complete set of schematic diagrams for all printed cards is available from Hoffer Flow Controls for users who wish their own personnel to service the measuring systems.

NOTE:

- ◆ *All printed circuit cards are warranted for one year after date of sale.*
- ◆ *All printed circuit cards may be factory repaired at a nominal fee for parts and labor after warranty period.*

TROUBLESHOOTING AND MAINTENANCE

INTRODUCTION

In case of an inoperable or malfunctioning system the following procedures can be used to isolate the faulty wiring, printed circuit boards and/or alternate causes. The majority of repairs can be made in the field thereby reducing the time a unit is out of service.

A recommended spare parts list is given immediately following the troubleshooting portion of this manual. The necessary documentation is contained with this manual with the exception of the calibration data sheet for the turbine flowmeter. This calibration is supplied separately.

Factory consultation is available to assist in diagnosing problems. Note that in some cases factory repairs can be performed more easily than can be accomplished in the field.

Failure conditions are listed and the possible corrective actions given to eliminate the observed problem.

GENERAL INSPECTION TO DETERMINE IF UNIT IS OPERATING PROPERLY

Proper operation of the ACC-32 can be assumed when with power applied to the unit:

1. The pulse output produces a pulse train of the desired amplitude when flow through the flow transducer occurs.
2. The analog output produces a voltage output signal of 4-20 mA with a span corresponding to that established by the calibration procedure.

OBSERVED CONDITION

PROBLEM/CORRECTIVE ACTION

A. NO PULSE OUTPUT

1. Inspect terminal strip wiring for conformity to the installation instructions and for acceptance workmanship.
2. Verify fuse is good with an ohm meter. See dwg. ACC-32-403. (AC power only).
3. Determine if flowmeter rotor is fouled.
4. Defective pickup coil. Replace MCP.
5. Defective cable. Replace.
6. Defective ACC-32. Repair or replace.

B. PULSING OUTPUT WITH NO FLOW

1. Line voltage below 105V RMS. (AC power only).
2. Defective pickup coil. Replace.
3. Defective cable. Replace.
4. Defective ACC-32. Repair or replace.
5. DC input voltage below 18 VDC (DC power only).

C. ANALOG OUTPUT MALFUNCTION

1. Improper wiring termination. Correct wiring.
2. ACC-32 improperly calibrated. Recalibrate.
3. Defective circuitry with the ACC-32. Factory repair ACC-32.

NOTE: *Refer to flowmeter user's manual for repair instructions for the turbine flowmeter.*

Table 1 - Recommended Spare Parts List

MODEL ACC-32 MODULATED CARRIER CONDITIONER/CONVERTER		
PART NUMBER	DESCRIPTION	QUANTITY
1/20 AMP	Fuse, power supply (AC Power Only)	1 Box
ACC-32-XX	Modulated Carrier/Conditioner/Converter	1
MCP	Modulated Carrier Pickup	1

NOTE: *Additional spare parts may be recommended for the turbine flowmeter. See user's manual for turbine flowmeter for details.*

REVISIONS			
REV	DESCRIPTION	DATE	APP
A	TIED SHIELD TO COMMON.	12/82	JD
B	REVISED AND REDRAWN. (CS)	920929	JD
C	DWG NO. WAS ACC32-302. (CS)	951117	JD
D	DWG NO. WAS 700-0110	000627	JD

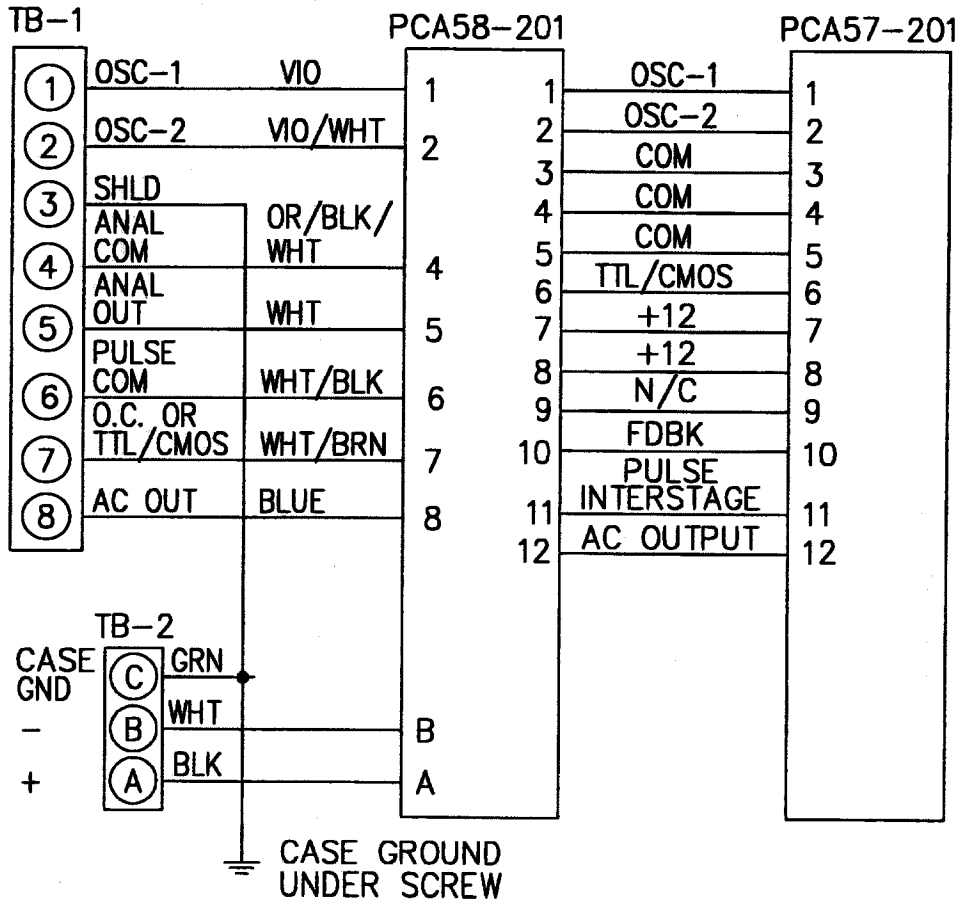

REPLACES 700-0110

		MATERIAL	CONTRACT/JN		 HOFFER FLOW CONTROLS, INC. ELIZABETH CITY, NC 27909	
			DRAWN R.S.	DATE 11/82		
			CHECK J.D.	DATE 11/82		
		FINISH	QA			
			PROJ ENG K.HOFFER	DATE 11/82	TITLE	
		CONFIDENTIAL PROPERTY OF HOFFER FLOW CONTROLS, INC. (HFC) NOT TO BE DISCLOSED TO OTHERS, REPRODUCED, OR USED FOR ANY OTHER PURPOSE, EXCEPT AS AUTHORIZED IN WRITING BY HFC. MUST BE RETURNED ON DEMAND, ON COMPLETION OF ORDER OR OTHER PURPOSE FOR WHICH LENT.	UNLESS OTHERWISE SPECIFIED DIMENSIONS ARE IN INCHES TOLERANCES OTHER THAN RAW MATERIAL SHALL BE HELD AS FOLLOWS:		WIRING, INTERNAL CASE- ACC32	
NEXT ASSY	USED ON		2 PLACE DECIMAL ±.01	3 PLACE DECIMAL ±.005		SIZE FSCM NO DWG NO REV
APPLICATION			FRACTIONAL ±1/64	ANGULAR ±1/2°		A 33321 ACC32-302 D
				SCALE NONE	SHEET 1 OF 1	