

ACC-51

SIGNAL CONDITIONER

USER'S MANUAL



HP-251
January 2009

H **HOFFER FLOW CONTROLS, INC.**
The Turbine Flowmeter Company

107 Kitty Hawk Lane, P.O. Box 2145, Elizabeth City, NC 27906-2145
800-628-4584 252-331-1997 FAX 252-331-2886
www.hofferflow.com E-mail: info@hofferflow.com

Notice

HOFFER FLOW CONTROLS, INC. MAKES NO WARRANTY OF ANY KIND WITH REGARD TO THIS MATERIAL, INCLUDING, BUT NOT LIMITED TO, THE IMPLIED WARRANTIES OF MERCHANTABILITY AND FITNESS FOR A PARTICULAR PURPOSE.

This manual has been provided as an aid in installing, connecting, calibrating, operating, and servicing this unit. Every precaution for accuracy has been taken in the preparation of this manual; however, HOFFER FLOW CONTROLS, INC. neither assumes responsibility for any omissions or errors that may appear nor assumes liability for any damages that may result from the use of the products in accordance with information contained in the manual.

HOFFER FLOW CONTROLS' policy is to provide a user manual for each item supplied. Therefore, all applicable user manuals should be examined before attempting to install or otherwise connect a number of related subsystems.

During installation, care must be taken to select the correct interconnecting wiring drawing. The choice of an incorrect connection drawing may result in damage to the system and/or one of the components.

Please review the complete model number of each item to be connected and locate the appropriate manual(s) and/or drawing(s). Identify all model numbers exactly before making any connections. A number of options and accessories may be added to the main instrument, which are not shown on the basic user wiring. Consult the appropriate option or accessory user manual before connecting it to the system. In many cases, a system wiring drawing is available and may be requested from HOFFER FLOW CONTROLS.

This document contains proprietary information, which is protected by copyright. All rights are reserved. No part of this document may be photocopied, reproduced, or translated to another language without the prior written consent of HOFFER FLOW CONTROLS, INC.

HOFFER FLOW CONTROLS' policy is to make running changes, not model changes, whenever an improvement is possible. This affords our customers the latest in technology and engineering. The information contained in this document is subject to change without notice.

RETURN REQUESTS / INQUIRIES

Direct all warranty and repair requests/inquiries to the Hoffer Flow Controls Customer Service Department, telephone number (252) 331-1997 or 1-800-628-4584. BEFORE RETURNING ANY PRODUCT(S) TO HOFFER FLOW CONTROLS, PURCHASER MUST OBTAIN A RETURNED MATERIAL AUTHORIZATION (RMA) NUMBER FROM HOFFER FLOW CONTROLS' CUSTOMER SERVICE DEPARTMENT (IN ORDER TO AVOID PROCESSING DELAYS). The assigned RMA number should then be marked on the outside of the return package and on any correspondence.

FOR **WARRANTY** RETURNS, please have the following information available BEFORE contacting HOFFER FLOW CONTROLS:

1. P.O. number under which the product was PURCHASED,
2. Model and serial number of the product under warranty, and
3. Repair instructions and/or specific problems relative to the product.

FOR **NON-WARRANTY** REPAIRS OR **CALIBRATIONS**, consult HOFFER FLOW CONTROLS for current repair/calibration charges. Have the following information available BEFORE contacting HOFFER FLOW CONTROLS:

1. P.O. number to cover the COST of the repair/calibration,
2. Model and serial number of the product, and
3. Repair instructions and/or specific problems relative to the product.

LIMITED WARRANTY

HOFFER FLOW CONTROLS, INC. ("HFC") warrants HFC's products ("goods") described in the specifications incorporated in this manual to be free from defects in material and workmanship under normal use and service, but only if such goods have been properly selected for the service intended, properly installed and properly operated and maintained. This warranty shall extend for a period of one (1) year from the date of delivery to the original purchaser (or eighteen (18) months if the delivery to the original purchaser occurred outside the continental United States). This warranty is extended only to the original purchaser ("Purchaser"). *Purchaser's sole and exclusive remedy is the repair and/or replacement of nonconforming goods as provided in the following paragraphs.*

In the event Purchaser believes the goods are defective, the goods must be returned to HFC, transportation prepaid by Purchaser, within twelve (12) months after delivery of goods (or eighteen (18) months for goods delivered outside the continental United States) for inspection by HFC. If HFC's inspection determines that the workmanship or materials are defective, the goods will be either repaired or replaced, at HFC's sole determination, free of additional charge, and the goods will be returned, transportation paid by HFC, using the lowest cost transportation available.

Prior to returning the goods to HFC, Purchaser must obtain a Returned Material Authorization (RMA) Number from HFC's Customer Service Department within 30 days after discovery of a purported breach of warranty, but no later than the warranty period; otherwise, such claims shall be deemed waived. See the Return Requests/Inquiries Section of this manual.

If HFC's inspection reveals the goods are free of defects in material and workmanship or such inspection reveals the goods were improperly used, improperly installed, and/or improperly selected for service intended, HFC will notify the purchaser in writing and will deliver the goods back to Purchaser upon (i) receipt of Purchaser's written instructions and (ii) the cost of transportation. If Purchaser does not respond within thirty (30) days after notice from HFC, the goods will be disposed of in HFC's discretion.

HFC does not warrant these goods to meet the requirements of any safety code of any state, municipality, or other jurisdiction, and Purchaser assumes all risk and liability whatsoever resulting from the use thereof, whether used singly or in combination with other machines or apparatus.

This warranty shall not apply to any HFC goods or parts thereof, which have been repaired outside HFC's factory or altered in any way, or have been subject to misuse, negligence, or accident, or have not been operated in accordance with HFC's printed instructions or have been operated under conditions more severe than, or otherwise exceeding, those set forth in the specifications for such goods.

THIS WARRANTY IS EXPRESSLY IN LIEU OF ALL OTHER WARRANTIES, EXPRESSED OR IMPLIED, INCLUDING ANY IMPLIED WARRANTY OF MERCHANTABILITY OR FITNESS FOR A PARTICULAR PURPOSE. HFC SHALL NOT BE LIABLE FOR ANY LOSS OR DAMAGE RESULTING, DIRECTLY OR INDIRECTLY, FROM THE USE OR LOSS OF USE OF THE GOODS. WITHOUT LIMITING THE GENERALITY OF THE FOREGOING, THIS EXCLUSION FROM LIABILITY EMBRACES THE PURCHASER'S EXPENSES FOR DOWNTIME OR FOR MAKING UP DOWNTIME, DAMAGES FOR WHICH THE PURCHASER MAY BE LIABLE TO OTHER PERSONS, DAMAGES TO PROPERTY, AND INJURY TO OR DEATH OF ANY PERSONS. HFC NEITHER ASSUMES NOR AUTHORIZES ANY PERSON TO ASSUME FOR IT ANY OTHER LIABILITY IN CONNECTION WITH THE SALE OR USE OF HFC'S GOODS, AND THERE ARE NO ORAL AGREEMENTS OR WARRANTIES COLLATERAL TO OR AFFECTING THE AGREEMENT. *PURCHASER'S SOLE AND EXCLUSIVE REMEDY IS THE REPAIR AND/OR REPLACEMENT OF NONCONFORMING GOODS AS PROVIDED IN THE PRECEDING PARAGRAPHS. HFC SHALL NOT BE LIABLE FOR ANY OTHER DAMAGES WHATSOEVER INCLUDING INDIRECT, INCIDENTAL, OR CONSEQUENTIAL DAMAGES.*

TABLE OF CONTENTS

SECTION I	
INTRODUCTION AND SPECIFICATIONS	1.1
SECTION II	
INSTALLATION	2.1
SECTION III	
CALIBRATION	3.1
SECTION IV	
OPERATION	4.1
SECTION V	
MAINTENANCE AND SCHEMATIC	5.1

SECTION I

MODEL ACC51 FLOWMETER SIGNAL CONDITIONER/PULSE SCALER

GENERAL DESCRIPTION

The Model ACC-51 is a signal conditioning and pulse scaling accessory model available for use with all Hoffer Turbine Flowmeters equipped with a magnetic pickoff. The ACC-51 provides a scaled pulse output which may be field calibrated to the desired number of pulses per unit volume. Typical outputs which may be realized are one pulse per gallon, or ten pulses per liter, etc.

This interface subsystem approach allows for direct interfacing with a host system without requiring special software considerations being given to the method of input and storage of flowmeter calibration constants. Partitioning of the system by this means will also allow for easy field adjustment when such calibration constants change due to repair or replacement. The calibration scaling factor is entered into a digital thumbwheel switch matrix.

The input signal conditioning circuitry is designed to accept the low level flowmeter signal while providing rejection of unwanted noise and spurious signals. A signal threshold control is provided which allows the user to set the input sensitivity above the ambient noise level, thereby eliminating any false signal on the output.

Several output options are available which provide flexibility in the interface as required by the host system. The output is available in the form of a CMOS/TTL compatible pulse and in the form of an open collector pulse. The pulse duration is factory calibrated as specified by the end user.

SPECIFICATIONS

Input	Input filtered, RF and Bandpass Filtered. Adjustable Trigger Level. Input Impedance - 10mVrms 10-1000 Hz. Over Voltage Capability 120 Vrms(absolute).
Pulse Scaling	System Factor and System Factor Multiplier provides a cascaded chain of two scaling factors. The system factor provides for scaling factors of .0000 to .9999 with four thumbwheel switches. The system factor multiplier provides additional scaling factors of 1, .1, .01, .001,.0001.

Output Pulse Duration - Factory Wired per user
Characteristics requirements. Contact factory for limitations.

Open Collector Type - 2N6660.
Vmax 60 Vdc Absolute Max.
Imax 1.2 Adc Absolute Max.

CMOS/TTL Logic 1 2.4 Vdc @ -.800mA.
Logic 0 0.4 Vdc @ 2.6mA.

High Level Pulse Output may be provided with a pull-up resistor to the input power supply.

Input Power 8-35 Vdc @ 10mA.
Reverse Polarity Protected
Input Filtered

Environmental Operating Temperature 0 to 70EC (STD)
Storage Temperature -65 to 150EC
Enclosures Available in Style-1 (STD)
Also available in Nema 4, and Explosion Proof UL Class I, Group D, Class II.

CONTROLS AND ADJUSTMENTS

Sensitivity A multiple turn control used to set the trigger level above the noise level.

System Factor A switch array composed of four switches which are used to enter the desired scaling factor. Used in conjunction with the system factor multiplier.

System Factor Multiplier A dip switch used to enter the desired system factor multiplier. Used in conjunction with the system factor.

ORDERING INFORMATION

MODEL ACC51-(A)-(B)-(C)-(D)

PULSE OUTPUT

PULSE DURATION

INPUT POWER

ENCLOSURE STYLE

PULSE OUTPUT

MODEL ACC51-(A)-()-()-()

OPTION (A)

- (1) TTL/CMOS
- (2) OPEN COLLECTOR
- (3) HIGH LEVEL PULSE
- (5) 0-10 V SQUARE WAVE

PULSE DURATION

MODEL ACC51-()-(B)-()-()

OPTION (B)

(SPECIFY IN ms)

INPUT POWER

MODEL ACC51-()-()-(C)-()

OPTION (C)

- (MS) MAGNETIC COIL
- (RF) MC3P COIL

ENCLOSURE STYLE

MODEL ACC51-()-()-()-(D)

OPTION (D)

- (1) STYLE 1 CASE, GENERAL PURPOSE
- (3H/O) MEETS CLASS 1, DIV. 1 AND 2, GROUP D ONLY
CLASS II, GROUPS E, F, G
CLASS III
NEMA 4X WITH 'O' RING
CERTIFIED CSA, UL
BODY KILARK #GECCT-3, STOCK #200-0945
FLAT COVER, STOCK #200-0533, KILARK #GECBC.
- (3BH/O) MEETS CLASS I, DIV. 1 AND 2, GROUPS A, B, C, D
CLASS 1, ZONES 1 AND 2, GROUPS IIB + H2, IIA
CLASS II, DIV. 1 AND 2, GROUPS E, F, G
CLASS III
NEMA 3, 4, 7 (B, C, D), 9 (E, F, G)
CERTIFIED CENELEC, CSA, UL, FM
BODY KILARK #HKB, STOCK #200-0406
DOME COVER, STOCK #200-0405, KILARK #HK2D.

NOTE: INSERT (X) IN MODEL NUMBER FOR EVERY OPTION NOT SPECIFIED.

THIS PAGE LEFT INTENTIONALLY BLANK.

SECTION II

FLOWMETER INSTALLATION

GENERAL

Proper Installation of the turbine flowmeter requires a suitable piping installation in order to achieve accurate and reliable operation.

The piping configuration immediately preceding and following the flowmeter is termed the meter run. Refer to the manufacturer's outline and installation instructions when installing the flowmeter and meter run.

RELATIVE - The performance of the turbine flowmeter is affected by fluid swirl and non-uniform velocity profiles. The following recommendation will reduce such flow irregularities.

It is advisable not to locate the meter run immediately downstream of pumps, partially opened valves, bends or other similar piping configurations. In addition, the area surrounding the flowmeter should be free of sources of electrical noise such as motors, solenoids, transformers and power lines which may be coupled to the pickoff device.

The metering section should not be subjected to excessive vibration or shock. Such a condition may result in a mechanically induced output signal from the pickoff device.

METER RUN - In general, the meter run should be chosen to have the same inner diameter as the meter bore. A minimum of 10 pipe diameters of straighten pipe upstream and 5 pipe diameters downstream are required. Where this optimum line configuration cannot be implemented, it is advisable to install a flow straightener properly positioned upstream of the flowmeter. Orientation is not a critical factor, however, horizontal is preferred orientation.

BYPASS RUN - A properly sized bypass run with suitable blocking valves may be equipped where an interruption in fluid flow for turbine meters servicing cannot be tolerated.

STRAINER - A strainer, filter and/or air eliminator is recommended to reduce the potential of fouling or damage. See table for recommended mesh size.

On initial startup of a line, it is advisable to install a spool piece purging the line to eliminate damaging the flowmeter, due to flux, tape, solder, welds or other contaminants carried along by the fluid stream.

CAVITATION - Cavitation causes measurement inaccuracies in turbine flowmeters and should be avoided by suitable line and operating configurations.

Whenever the pressure within a pipeline instantaneously falls below the equilibrium vapor pressure of the fluid, a portion of the fluid vaporizes and forms bubbles in the pipeline. This is termed cavitation. Cavitation is eliminated by maintaining adequate back pressure on the flowmeter. A downstream valve that provides the necessary back pressure is one means for preventing cavitation in the metering run. Control valves should be located downstream, if possible. Some installations may also make use of a vapor eliminator upstream of the flowmeter.

The minimum required back pressure may be estimated using the following equation:

$$\text{Min. Back Pressure} = 1.25 \times \text{Vapor Pressure} + 2 \times \text{Pressure Drop}$$

INSTALLATION WIRING LAYOUT FOR INTERCONNECTIONS

In considering the interconnections between the flowmeter and the flow measurement system some attention must be given to the anticipated noise sources and the coupling of these sources to the interconnecting wiring.

Noise signals may be coupled inductively or capacitively into the wiring between the flowmeter and the electronic measuring systems. In general, utilizing a shielded, twisted pair for the interconnection greatly reduces this coupling. The shield should be grounded on one end of the cable only. In general, grounding only on the electronic measuring system is best.

However, even with proper interconnecting cabling crosstalk with other lines or power lines may still occur and should be avoided. Physical isolation in the manner in which the wiring is run reduces the chance of potential problems.

It is common to transmit the low level output signal from the flowmeter several hundred feet through a shielded, twisted pair instrument cable. Where a noisy environment is suspect, it is recommended that a preamplifier be installed on or near the flowmeter to assure the preservation of flow information from the flowmeter to the electronic measuring system. Suitable accessory models are available from manufacturer.

SECTION III

CALIBRATION AND SETUP OF ACC51 FLOWMETER SIGNAL CONDITIONING INTERFACE SUBSYSTEM

INTRODUCTION

The ACC51 Flowmeter Signal Conditioning/Interface/Subsystem manufactured by Hoffer Flow Controls has a special feature which allows the user to scale the flow information into the desired units of measurement. This feature is termed the SYSTEM FACTOR and is composed of two arrays of switches.

By utilizing the SYSTEM FACTOR, the total flow may be indicated as pulse outputs in gallons, pints, liters, barrels, cc's.

PROCEDURE

Begin by obtaining a copy of the calibration sheet for the flowmeter to be used with the ACC51. Obtain the desired units of measurement from the project supervisor or equipment specification.

From the calibration sheet for the flowmeter obtain the MEAN K FACTOR in cycles/gallon, designate this as the K FACTOR.

Finally, note the maximum flowrate in desired units as R(MAX) in unit volumes/minute. the value of R(MAX) should be less than the maximum count speed for the host system.

Compute the equivalent number of pulses per desired measurement unit, designated K', from the K FACTOR for the flowmeter and the conversion factor relating the gallons per user's desired measurement units. This may be done with the following equation and the aid of a conversion chart.

$K' = K \text{ FACTOR} \times CF$ WHERE

CF is the conversion factor equal to the ratio of the number of gallons per user chosen volume unit.

Example:

Given: 200 pulses/gallon = K FACTOR
 Desire units of measurement = Liters

Obtain: Conversation Factor CF = .2642 gallons/liter from Table

Calculate: $K' = 200 \times .2642$
 = 52.84 $\frac{\text{Pulses}}{\text{Liter}}$

CALIBRATION AND SETUP OF ACC51 FLOWMETER SIGNAL CONDITIONER/INTERFACE SUBSYSTEM

SYSTEM FACTOR CALCULATION

For operation with standard, in-line, axial flowmeters.

Determine the SYSTEM FACTOR by the following equation:

$$SF = \frac{1}{K}$$

Example:

$$SF = \frac{1}{52.84} = .0189251$$

Concerning the SYSTEM FACTOR and SYSTEM FACTOR MULTIPLIER

From the description given in the Controls and Adjustment Section, it may be observed that the SYSTEM FACTOR and SYSTEM FACTOR MULTIPLIER are used together as a scale factor to provide the pulse output of total flow in the user desired units.

It is important to consider how to best represent a required scale factor within the limitation of SYSTEM FACTOR and SYSTEM FACTOR MULTIPLIER.

The SYSTEM FACTOR should be programmed with the largest number of significant figures which may be represented within the limitations of the switch array.

The SYSTEM FACTOR MULTIPLIER is then set to the position which results in the correct scale factor.

Example:

S. F. = .0189251

Dial into SYSTEM FACTOR SWITCHES .1893.

SYSTEM FACTOR MULTIPLIER SWITCH to X.1 position.

SECTION IV

PRINCIPLE OF OPERATION

A simplified block diagram of the Model ACC51, is given in drawing ACC51-601. Key functional blocks, as well as information flow are designated. The basic operation of the system is as follows.

The frequency signal from the turbine flowmeter is connected to the Model ACC51 with a twisted pair shielded cable. The signal enters through the SENSITIVITY control which is used to reject unwanted noise by raising the trigger threshold above the background noise present.

The low level flowmeter signal is then passed through a signal conditioning chain where it is then filtered, amplified and shaped into a train of digital pulses whose frequency is related to the volume flow rate and where each pulse represents a discrete volume of fluid.

The linear signal in the form of a pulse train is then passed to the System Factor which scales the signal for totalization.

The pulse scaling circuitry composing the System Factor affectively multiplies the pulse rate by a number set into the digital thumb wheel switch array on the PCA-62 printed circuit card.

At the output of the System Factor, each pulse represents a decimal multiple of the desired flow measurement units.

The pulse train is fed to the System Factor Multiplier which effectively multiplies the pulse rate by either 1, .1, .01, .001 or .0001 depending on the position selected on the corresponding switch.

At the output of the System Factor Multiplier block, each pulse represents one unit of flow in the desired measurement units.

The pulse train is then passed through an output drive stage which is connected to a host system. A pulse is output each time a discrete volume of fluid, represented in the desired units, passes through the flowmeter.

OPERATION

INITIAL STARTUP

Perform any purging of piping with spool piece in place. Once completed, install the flowmeter and connect cabling to pickup coil.

With the Flow Measurement System properly installed and calibrated, verify the following performance checks before placing the system into active service.

With the power to the unit, and NO flow through the flowmeter, the pulse output frequency should be 0. If the output pulse frequency is greater than 0, input noise may be present.

Slowly turn the SENSITIVITY threshold control counterclockwise until a pulse rate of 0 is indicated.

NOTE - Turning the SENSITIVITY control fully counterclockwise will render the unit inoperative.

GENERAL OPERATION

Apply power to the unit 8-35 VDC.

The ACC51 will output the desired units of pulses per unit volume established by the calibration setup procedure.

Pulses output begins automatically when flow through the flowmeter commences.

SECTION V

MAINTENANCE, GENERAL

Hoffer Flow Controls Flow Measurement Systems are constructed to give a long service life in the targeted measuring field and service environment. However, problems do occur from time to time and the following points should be considered for preventive maintenance and repairs.

The bearing type used in the flowmeter was chosen to give compromise between long life, chemical resistance, ease of maintenance and performance. A preventive maintenance schedule should be established to determine the amount of wear which has occurred since last overhaul. See user's manual for flowmeter for further instructions.

A spare parts list has been provided which, at the discretion of the user, may be user stocked. Consult with the manufacturer if an abridged spare parts list is sought. The recommended spare parts list may be found following this section and in the user's manual for the flowmeter.

In case the flow measurement system malfunctions or becomes inoperative, a troubleshooting procedure is enclosed.

Factory consultation is available to assist in diagnosing problems. In addition, factory repair parts and service are available for individuals who wish to utilize this service.

A complete set of schematic diagrams for all printed cards is available from Hoffer Flow Controls for users who wish their own personnel to service the measuring system.

TROUBLESHOOTING AND MAINTENANCE

INTRODUCTION

In case of an inoperable or malfunctioning system the following procedures can be used to isolate the faulty wiring, printed circuit boards and/or alternate caused. The majority of repairs can be made in the field thereby reducing the time a unit is out of service.

A recommended spare parts list is given immediately following the troubleshooting portion of this manual. The necessary documentation is contained within this manual with the exception of the calibration data sheet for the turbine flowmeter. This calibration is supplied separately.

Factory consultation is available to assist in diagnosing problems. Note that in some cases factory repairs can be performed more easily than can be accomplished in the field.

Failure conditions are listed and the possible corrective actions given to eliminate the observed problem.

GENERAL INSPECTION TO DETERMINE IF UNIT IS OPERATING PROPERLY

Proper operation of the ACC51 can be assumed when with power applied to the unit, the pulse output produces a pulse train of the desired amplitude when flow through the flow transducer occurs.

<u>OBSERVED CONDITION</u>	<u>POSSIBLE CAUSE</u>	<u>CORRECTIVE ACTION</u>
Unit does not produce pulse output with flow present.	Power Loss	Check interconnecting wiring and host system.
	Bad pickup coil or signal cable.	Check coil and cable for continuity and leakage. Replace if BAD.
	Fouled or damaged turbine flowmeter.	Remove and clean per manufacturers recommended procedure.
	Bad ACC51.	Repair or replace with unit.
	Sensitivity Pot turned too far clockwise.	Readjust Sensitivity control.
Unit produces output pulse with no flow present.	Input noise.	Turn Sensitivity Pot clockwise until false output stops.
	Bad pickup coil or open signal cable.	Check coil and cable for continuity and leakage. Replace if BAD.
	Extreme shock or vibration of piping.	Dampen or relocate flowmeter.
	Power supply malfunction.	Check and repair as required.
	Bad ACC51.	Repair or replace with new unit.

NOTE:

- ALL PRINTED CIRCUIT CARDS ARE WARRANTIED FOR ONE YEAR AFTER DATE OF SALE.
- ALL PRINTED CIRCUIT CARDS MAY BE FACTORY REPAIRED AT A NOMINAL FEE FOR PARTS AND LABOR AFTER WARRANTEE PERIOD.

ACC51 SIGNAL CONDITIONER RECOMMENDED SPARE PARTS

<u>PART NUMBER</u>	<u>DESCRIPTION</u>	<u>QTY.</u>
MS306A-10SL-4S	SIGNAL CONDITIONER	1
CONSULT WITH FACTORY	PICKUP COIL	1
CONSULT WITH FACTORY	BEARINGS	1 SET
ACC51	SIGNAL CONDITIONER	1

NOTES:

1. FACTORY RECOMMENDS 10" PIPE DIA. UPSTREAM AND 5 PIPE DIA. DOWNSTREAM OF SAME SIZE PIPE AS FLOWMETER. A FLOW STRAIGHTENER IS RECOMMENDED IF THIS IS NOT POSSIBLE OR FOR CUSTODY TRANSFER APPLICATIONS.

REVISIONS

REV	DESCRIPTION	DATE	APP
A	REDRAWN	1-31-92	
B	ADDED NOTE 2, CHG'D MESH SIZE	3-17-92	
C	DRAWING NO. WAS INSTL-104.	950907	JR

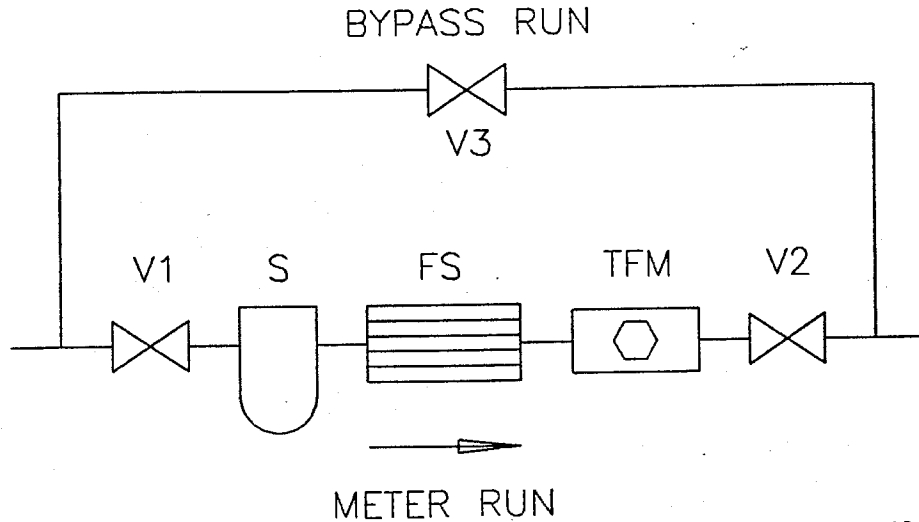

METER SIZE	MESH SIZE
MF SERIES	100
1/4" - 1/2"	100
5/8" - 1 1/4"	70
1 1/2" - 3"	40
4" - 12"	24

- V1, V2 BLOCKING VALVE
- S STRAINER
- FS FLOW STRAIGHTENER
- TFM TURBINE FLOWMETER
- V3 BYPASS VALVE

REPLACES INSTL-104

		MATERIAL	DRAWN DW	DATE 1-31-92	 H OFFER FLOW CONTROLS, INC. ELIZABETH CITY, NC 27909
			CHECK JD	1-31-92	
			QA H. COVELL	1-31-92	
		FINISH	PROJ ENG KRH	1-31-92	
			CONFIDENTIAL PROPERTY OF HOFFER FLOW CONTROLS, INC. (HFC) NOT TO BE DISCLOSED TO OTHERS, REPRODUCED, OR USED FOR ANY OTHER PURPOSE, EXCEPT AS AUTHORIZED IN WRITING BY HFC. MUST BE RETURNED ON DEMAND, ON COMPLETION OF ORDER OR OTHER PURPOSE FOR WHICH LENT.		TITLE TYPICAL TURBINE INSTALLATION
NEXT ASSY	USED ON	UNLESS OTHERWISE SPECIFIED DIMENSIONS ARE IN INCHES TOLERANCES OTHER THAN RAW MATERIAL SHALL BE HELD AS FOLLOWS: 2 PLACE DECIMAL ±.01 3 PLACE DECIMAL ±.005 FRACTIONAL ±1/64 ANGULAR ±1/2°		SIZE A CAGE CODE 33321 DWG NO 500-0194 SCALE NONE REV C	
APPLICATION				SHEET 1 OF 1	

REVISIONS

REV	DESCRIPTION	DATE	APP
A	REDRAWN. (CS)	930413	gpc

TERMINAL	CONNECTION
1	FLOWMETER SIGNAL (WHT)
2	FLOWMETER SIGNAL (BLK)
3	SHIELD
4	PULSE OUTPUT
5	POWER/PULSE COMMON
6	POWER INPUT "+" DC

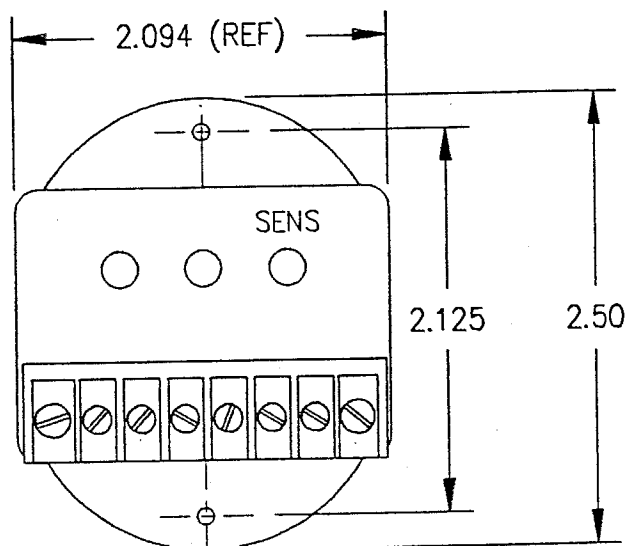
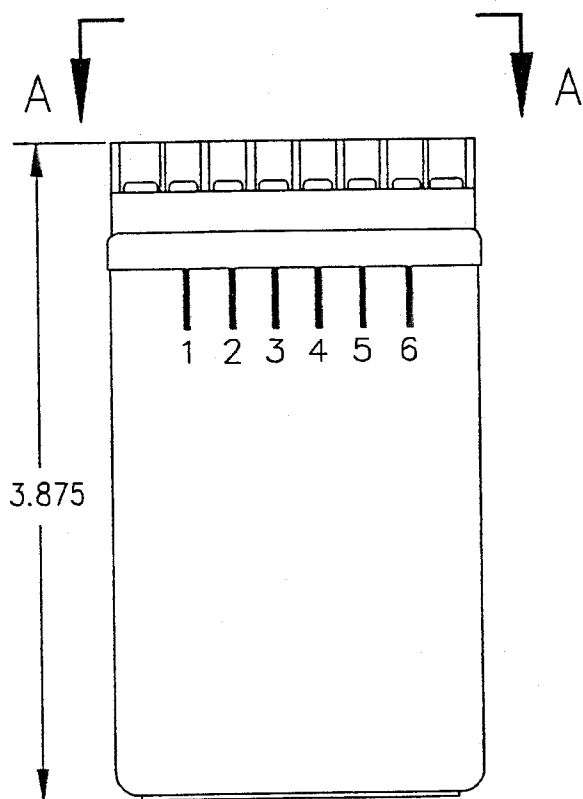

VIEW A-A

		MATERIAL	CONTRACT/JN		 HOFFER FLOW CONTROLS, INC. ELIZABETH CITY, NC 27909			
			DRAWN JF	DATE 9/82				
			CHECK					
		FINISH	QA					
			PROJ ENG RG	9/82	TITLE ACC51 OUTLINE, STYLE 1 CASE			
		CONFIDENTIAL PROPERTY OF HOFFER FLOW CONTROLS, INC. (HFC) NOT TO BE DISCLOSED TO OTHERS, REPRODUCED, OR USED FOR ANY OTHER PURPOSE, EXCEPT AS AUTHORIZED IN WRITING BY HFC. MUST BE RETURNED ON DEMAND, ON COMPLETION OF ORDER OR OTHER PURPOSE FOR WHICH LENT.	UNLESS OTHERWISE SPECIFIED DIMENSIONS ARE IN INCHES TOLERANCES OTHER THAN RAW MATERIAL SHALL BE HELD AS FOLLOWS: 2 PLACE DECIMAL ±.01 3 PLACE DECIMAL ±.005 FRACTIONAL ±1/64 ANGULAR ±1/2°		SIZE A	CAGE CODE 33321	DWG NO ACC51-701	REV A
NEXT ASSY	USED ON					SCALE NONE	SHEET 1 OF 1	
APPLICATION								

REVISIONS

REV	DESCRIPTION	DATE	APP
A	REDRAWN ON CAD. (CS)	930413	js

OUTLINE DIMENSIONS

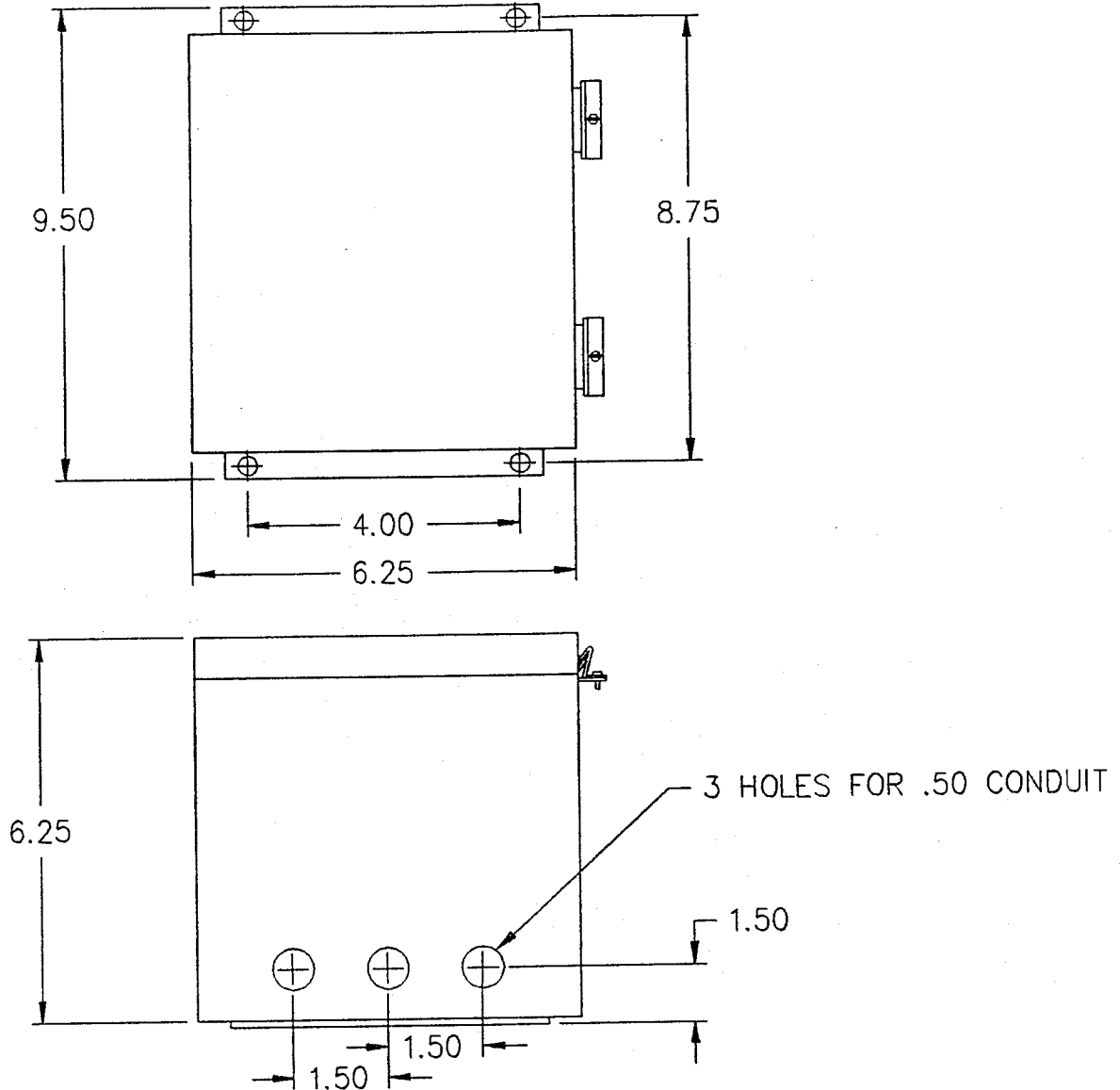



		MATERIAL	CONTRACT/JN		H HOFFER FLOW CONTROLS, INC. ELIZABETH CITY, NC 27909			
			DRAWN	DATE				
			CHECK		TITLE CASE OUTLINE- STYLE 5			
		FINISH	QA					
			PROJ ENG					
		CONFIDENTIAL PROPERTY OF HOFFER FLOW CONTROLS, INC. (HFC) NOT TO BE DISCLOSED TO OTHERS, REPRODUCED, OR USED FOR ANY OTHER PURPOSE, EXCEPT AS AUTHORIZED IN WRITING BY HFC. MUST BE RETURNED ON DEMAND, ON COMPLETION OF ORDER OR OTHER PURPOSE FOR WHICH LENT.	UNLESS OTHERWISE SPECIFIED DIMENSIONS ARE IN INCHES TOLERANCES OTHER THAN RAW MATERIAL SHALL BE HELD AS FOLLOWS:		SIZE	CAGE CODE	DWG NO	REV
NEXT ASSY	USED ON		2 PLACE DECIMAL ±.01 3 PLACE DECIMAL ±.005 FRACTIONAL ±1/64 ANGULAR ±1/2°			A	33321	ACC51-702
APPLICATION					SCALE	NONE		SHEET 1 OF 1

REVISIONS

REV	DESCRIPTION	DATE	APP
A	REDRAWN ON CAD. (CS)	930413	g e

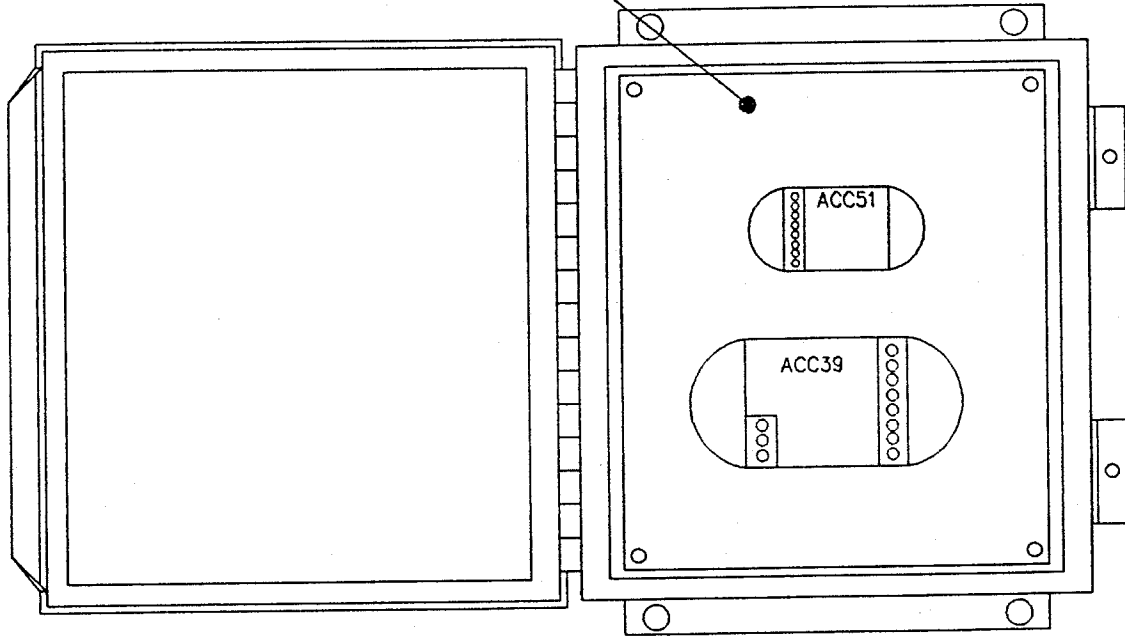
SUB PANEL



		MATERIAL	CONTRACT/JN		 HOFFER FLOW CONTROLS, INC. ELIZABETH CITY, NC 27909
			DRAWN	DATE	
			CHECK		TITLE INTERNAL LOCATION ACC39 & ACC51
		FINISH	QA		
			PROJ ENG		
		CONFIDENTIAL PROPERTY OF HOFFER FLOW CONTROLS, INC. (HFC) NOT TO BE DISCLOSED TO OTHERS, REPRODUCED, OR USED FOR ANY OTHER PURPOSE, EXCEPT AS AUTHORIZED IN WRITING BY HFC. MUST BE RETURNED ON DEMAND, ON COMPLETION OF ORDER OR OTHER PURPOSE FOR WHICH LENT.	UNLESS OTHERWISE SPECIFIED DIMENSIONS ARE IN INCHES TOLERANCES OTHER THAN RAW MATERIAL SHALL BE HELD AS FOLLOWS:		SIZE CAGE CODE DWG NO REV A 33321 ACC51-703 A
NEXT ASSY	USED ON		2 PLACE DECIMAL ±.01 3 PLACE DECIMAL ±.005 FRACTIONAL ±1/64 ANGULAR ±1/2°		
APPLICATION			SCALE	NONE	SHEET 1 OF 1

NOTES:

- ENCLOSURE MEETS:
CLASS I, GROUP C & D
CLASS II, GROUP E, F & G
NEMA 7 & 9
- USED WHEN SIGNAL CONDITIONER IS
ENCLOSED, MOUNTED OR REMOTE.

REVISIONS			
REV	DESCRIPTION	DATE	APP

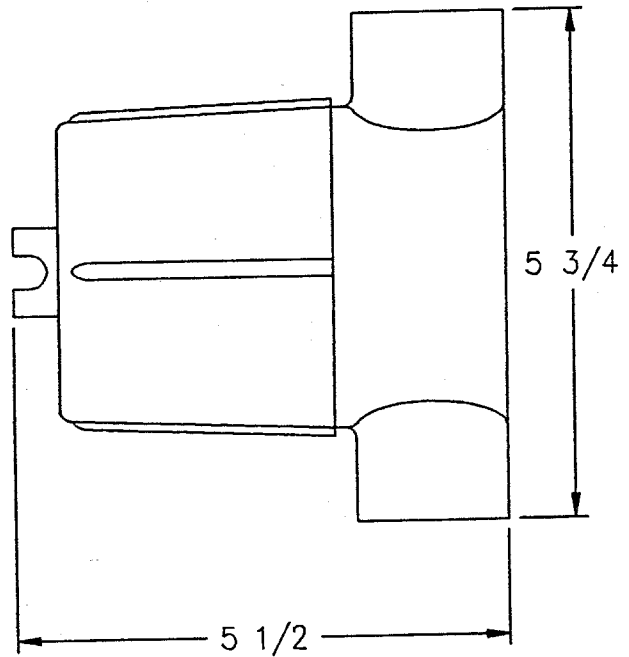
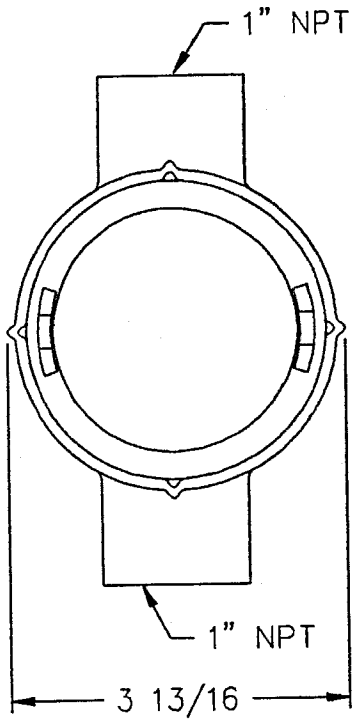

		MATERIAL	DRAWN <i>Sweet</i>	DATE 9/20/81	H HOFFER FLOW CONTROLS, INC. ELIZABETH CITY, NC 27909			
			CHECK					
			PROJ ENG <i>CA</i>	9/17/81				
		FINISH			TITLE			
					ENCLOSURE, EXPLOSION PROOF- STYLE 3			
		CONFIDENTIAL PROPERTY OF HOFFER FLOW CONTROLS, INC. (HFC) NOT TO BE DISCLOSED TO OTHERS, REPRODUCED, OR USED FOR ANY OTHER PURPOSE, EXCEPT AS AUTHORIZED IN WRITING BY HFC. MUST BE RETURNED ON DEMAND, ON COMPLETION OF ORDER OR OTHER PURPOSE FOR WHICH LENT.	UNLESS OTHERWISE SPECIFIED DIMENSIONS ARE IN INCHES TOLERANCES OTHER THAN RAW MATERIAL SHALL BE HELD AS FOLLOWS: 2 PLACE DECIMAL ±.01 3 PLACE DECIMAL ±.005 FRACTIONAL ±1/64 ANGULAR ±1/2°		SIZE	CAGE CODE	DWG NO	REV
NEXT ASSY	USED ON					A	33321	500-0018
APPLICATION					SCALE	NONE		SHEET 1 OF 1

NOTES:

ENCLOSURE MEETS:
 CLASS I, GROUPS C & D
 CLASS II, GROUPS E, F & G
 NEMA 7 & 9

REVISIONS

REV	DESCRIPTION	DATE	APP

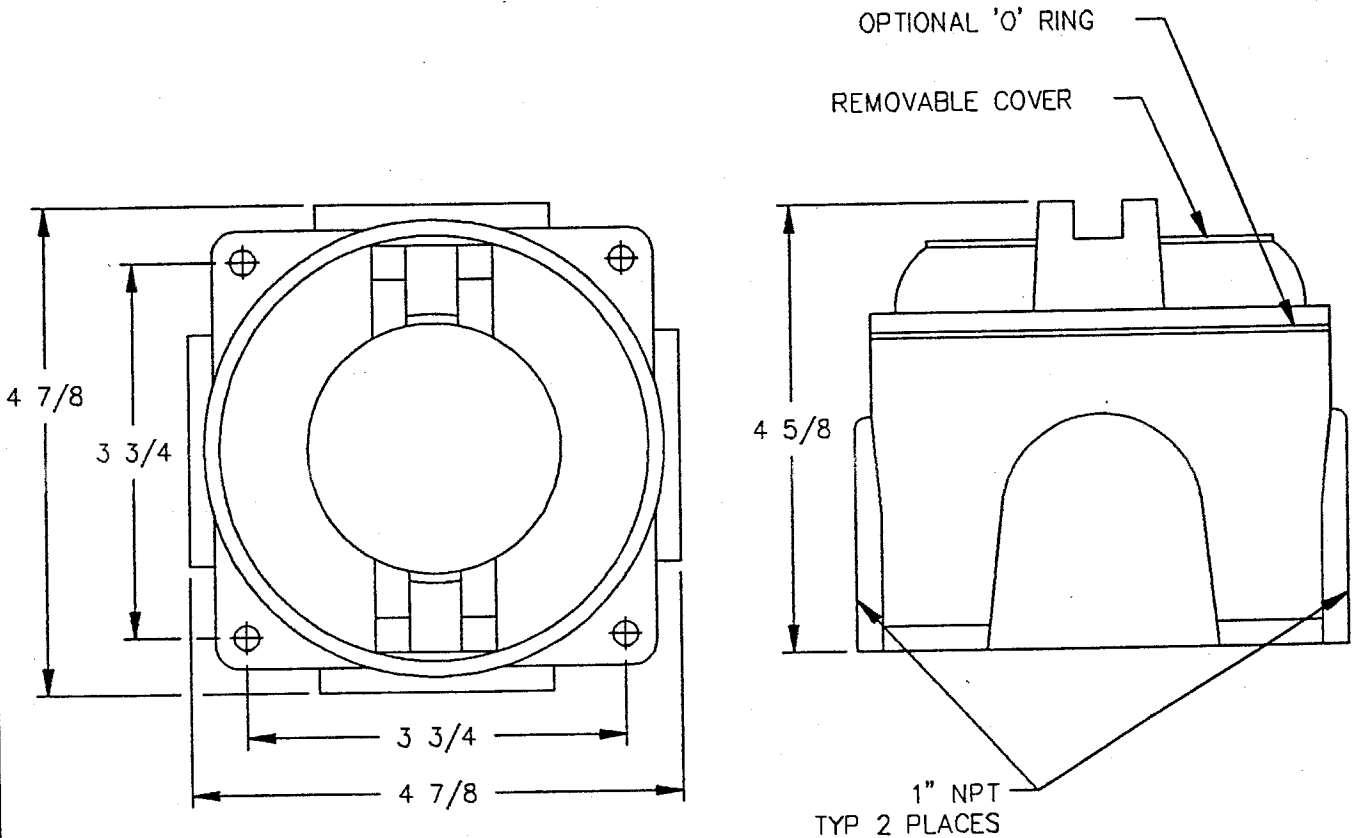



		MATERIAL	DRAWN <i>Sweet</i>	DATE 9/4/83	H HOFFER FLOW CONTROLS, INC. ELIZABETH CITY, NC 27909
			CHECK		
			PROJ ENG <i>SA</i>	9/1/83	TITLE
		FINISH			ENCLOSURE, EXPLOSION PROOF- STYLE 4
		CONFIDENTIAL PROPERTY OF HOFFER FLOW CONTROLS, INC. (HFC) NOT TO BE DISCLOSED TO OTHERS, REPRODUCED, OR USED FOR ANY OTHER PURPOSE, EXCEPT AS AUTHORIZED IN WRITING BY HFC. MUST BE RETURNED ON DEMAND, ON COMPLETION OF ORDER OR OTHER PURPOSE FOR WHICH LENT.	UNLESS OTHERWISE SPECIFIED DIMENSIONS ARE IN INCHES TOLERANCES OTHER THAN RAW AS FOLLOWS:		SIZE
			2 PLACE DECIMAL ±.01 3 PLACE DECIMAL ±.005 FRACTIONAL ±1/64 ANGULAR ±1/2°	FSCM NO	DWG NO
NEXT ASSY	USED ON				A 33321 500-0021 -
APPLICATION					SCALE NONE SHEET 1 OF 1

REVISIONS

REV	DESCRIPTION	DATE	APP
A	NEW DIP SWITCH. (RG)	12/86	
B	REDRAWN ON CAD (CS)	930402	JD
C	PER ECP 500-62	090108	/K.

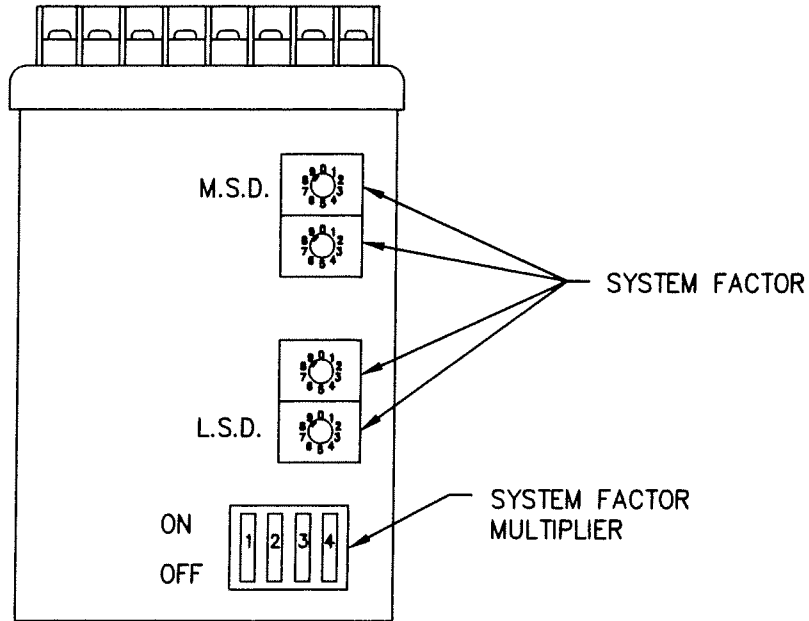
MULTIPLIER	SWITCH POSITION			
	1	2	3	4
X1	ON	OFF	OFF	OFF
X.1	OFF	ON	OFF	OFF
X.01	OFF	ON	ON	OFF
X.001	OFF	ON	OFF	ON
X.0001	OFF	ON	ON	ON



		MATERIAL	CONTRACT/JN	 HOFFER FLOW CONTROLS, INC. ELIZABETH CITY, NC 27909	
			DRAWN RG		DATE 12/83
			CHECK		
		FINISH	QA	TITLE	
			PROJ ENG RG	1/84	CONTROLS AND ADJUSTMENTS
		CONFIDENTIAL PROPERTY OF HOFFER FLOW CONTROLS, INC. (HFC) NOT TO BE DISCLOSED TO OTHERS, REPRODUCED, OR USED FOR ANY OTHER PURPOSE, EXCEPT AS AUTHORIZED IN WRITING BY HFC. MUST BE RETURNED ON DEMAND, ON COMPLETION OF ORDER OR OTHER PURPOSE FOR WHICH LENT.	UNLESS OTHERWISE SPECIFIED DIMENSIONS ARE IN INCHES TOLERANCES OTHER THAN RAW MATERIAL SHALL BE HELD AS FOLLOWS: 2 PLACE DECIMAL ±.01 3 PLACE DECIMAL ±.005 FRACTIONAL ±1/64 ANGULAR ±1/2°	SIZE CAGE CODE DWG NO REV	
NEXT ASSY	USED ON			A 33321 ACC51-401 C	
APPLICATION				SCALE NONE SHEET 1 OF 1	

REVISIONS			
REV	DESCRIPTION	DATE	APP
A	REDRAWN ON CAD. (CS)	930413	<i>JD</i>

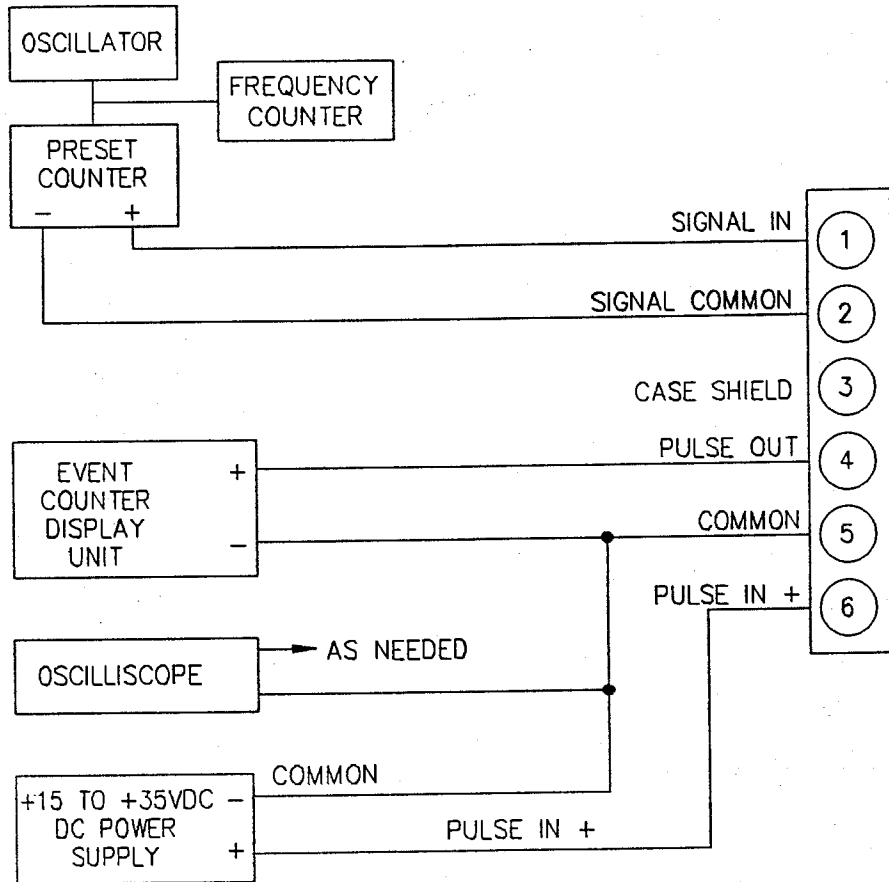

		MATERIAL	CONTRACT/JN		 HOFFER FLOW CONTROLS, INC. ELIZABETH CITY, NC 27909	
			DRAWN SAB	DATE 6/26/90		
			CHECK JD	6/26/90		
		FINISH	QA			
			PROJ ENG		TITLE ACC51 TEST SETUP FIGURE 1 (MAGNETIC)	
		CONFIDENTIAL PROPERTY OF HOFFER FLOW CONTROLS, INC. (HFC) NOT TO BE DISCLOSED TO OTHERS, REPRODUCED, OR USED FOR ANY OTHER PURPOSE, EXCEPT AS AUTHORIZED IN WRITING BY HFC. MUST BE RETURNED ON DEMAND, ON COMPLETION OF ORDER OR OTHER PURPOSE FOR WHICH LENT.	UNLESS OTHERWISE SPECIFIED DIMENSIONS ARE IN INCHES TOLERANCES OTHER THAN RAW AS FOLLOWS: 2 PLACE DECIMAL ±.01 3 PLACE DECIMAL ±.005 FRACTIONAL ±1/64 ANGULAR ±1/2°		SIZE CAGE CODE DWG NO REV A 33321 ACC51-602 A	
NEXT ASSY	USED ON		APPLICATION		SCALE NONE	SHEET 1 OF 1

REVISIONS			
REV	DESCRIPTION	DATE	APP
A	REDRAWN ON CAD. (CS)	930414	1 S

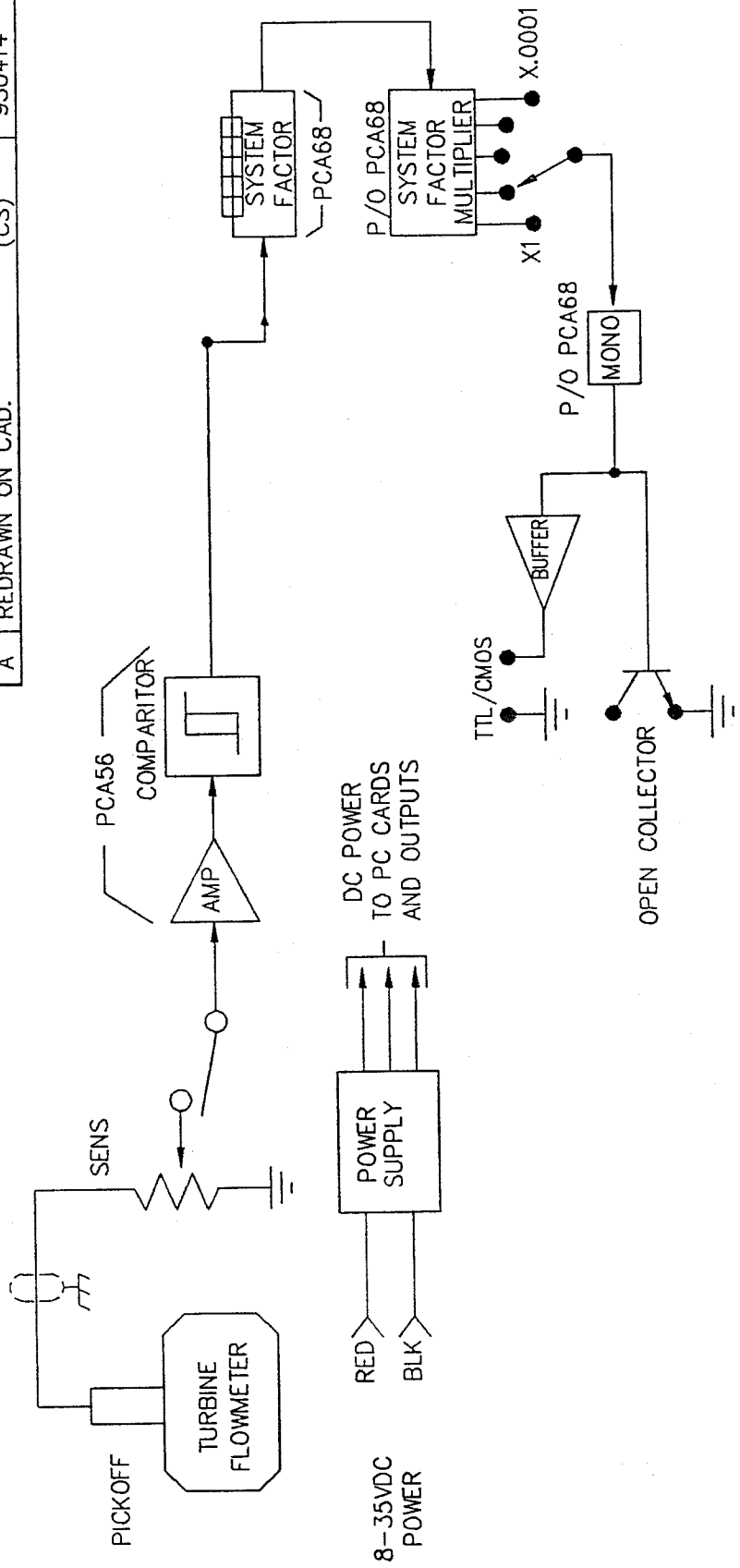

MATERIAL		CONTRACT/JN	
FINISH		DRAWN JD	DATE 12/84
		CHECK	
		QA	
		PROJ ENG JD	12/84
<p>CONFIDENTIAL PROPERTY OF HOFFER FLOW CONTROLS, INC. (HFC) NOT TO BE DISCLOSED TO OTHERS, REPRODUCED, OR USED FOR ANY OTHER PURPOSE, EXCEPT AS AUTHORIZED IN WRITING BY HFC. MUST BE RETURNED ON DEMAND, ON COMPLETION OF ORDER OR OTHER PURPOSE FOR WHICH LENT.</p>		<p>UNLESS OTHERWISE SPECIFIED DIMENSIONS ARE IN INCHES, TOLERANCES OTHER THAN THE SIZE OF RAW MATERIAL SHALL BE HELD AS FOLLOWS:</p> <p>2 PLACE DECIMAL ±.01 3 PLACE DECIMAL ±.005 ANGULAR ±1/2°</p>	
NEXT ASSY	USED ON		
APPLICATION			
<p>H HOFFER FLOW CONTROLS, INC. ELIZABETH CITY, NC 27909</p>			
<p>TITLE BLOCK DIAGRAM ACC51</p>			
SIZE	CAGE CODE	DWG NO	REV
A	33321	ACC51-601	A
SCALE	NONE	SHEET	1 OF 1

REVISIONS

REV	DESCRIPTION	DATE	APP
A	REDRAWN ON CAD. (CS)	930331	js

PCA56-ACC51
PCA56-20

PCA68
PCA68-201, 202

FLOWMETER SIG	SIG	1	A	3
COM	SIG COM	2	B	4
SHLD	GRN CASE GND	4	C	5
OUTPUT PULSE	PULSE BLUE	5	D	1
COMMON	COM PWR/PULSE BLK	6	E	2
POWER IN +	POWER OR		F	7
			G	6

H HOFFER FLOW CONTROLS, INC.
ELIZABETH CITY, NC 27907

TITLE
CASE WIRING,
PCA-51 WITH
MAG. PICKUP

SIZE	CAGE CODE	DWG NO	REV
A	33321	ACC51-301	A
SCALE	NONE	SHEET	1 OF 1

MATERIAL	CONTRACT/JN	DATE
	DRAWN RG	11/83
	CHECK	
	QA	
	PROJ ENG JD	12/83
	UNLESS OTHERWISE SPECIFIED DIMENSIONS ARE IN INCHES. TOLERANCES OTHER THAN THE SIZE OF RAW MATERIAL SHALL BE HELD AS FOLLOWS: 2 PLACE DECIMAL ±.01 3 PLACE DECIMAL ±.005 FRACTIONAL ±1/64 ANGULAR +1/2°	
	CONFIDENTIAL PROPERTY OF HOFFER FLOW CONTROLS, INC. (HFC) NOT TO BE DISCLOSED TO OTHERS, REPRODUCED, OR USED FOR ANY OTHER PURPOSE, EXCEPT AS AUTHORIZED IN WRITING BY HFC. MUST BE RETURNED ON DEMAND, ON COMPLETION OF ORDER OR OTHER PURPOSE FOR WHICH LENT.	
NEXT ASSY	USED ON	
APPLICATION		

NOTES:

1. FACTORY WIRED JUMPER OPTIONS FOR PULSE OUTPUT FORM.

REVISIONS

REV	DESCRIPTION	DATE	APP
A	REDRAWN ON CAD (CS)	930331	g d

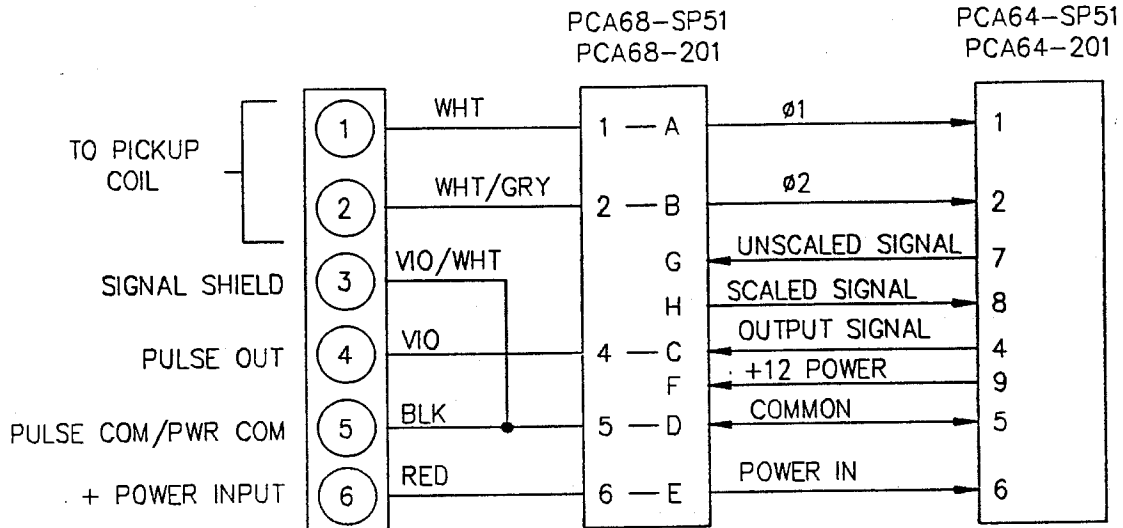

		MATERIAL	CONTRACT/JN		 HOFFER FLOW CONTROLS, INC. ELIZABETH CITY, NC 27909
			DRAWN	DATE	
			RG	12/83	
			CHECK		
		FINISH	QA		TITLE
			PROJ ENG	1/84	CASE WIRING, ACC51-()-()-1-MCP
		CONFIDENTIAL PROPERTY OF HOFFER FLOW CONTROLS, INC. (HFC) NOT TO BE DISCLOSED TO OTHERS, REPRODUCED, OR USED FOR ANY OTHER PURPOSE, EXCEPT AS AUTHORIZED IN WRITING BY HFC. MUST BE RETURNED ON DEMAND, ON COMPLETION OF ORDER OR OTHER PURPOSE FOR WHICH LENT.	UNLESS OTHERWISE SPECIFIED DIMENSIONS ARE IN INCHES TOLERANCES OTHER THAN RAW MATERIAL SHALL BE HELD AS FOLLOWS:		
			2 PLACE DECIMAL ±.01		SIZE
			3 PLACE DECIMAL ±.005		CAGE CODE
			FRACTIONAL ±1/64		DWG NO
		ANGULAR ±1/2°		REV	
NEXT ASSY	USED ON			A 33321	ACC51-302
APPLICATION				SCALE	SHEET 1 OF 2
				NONE	

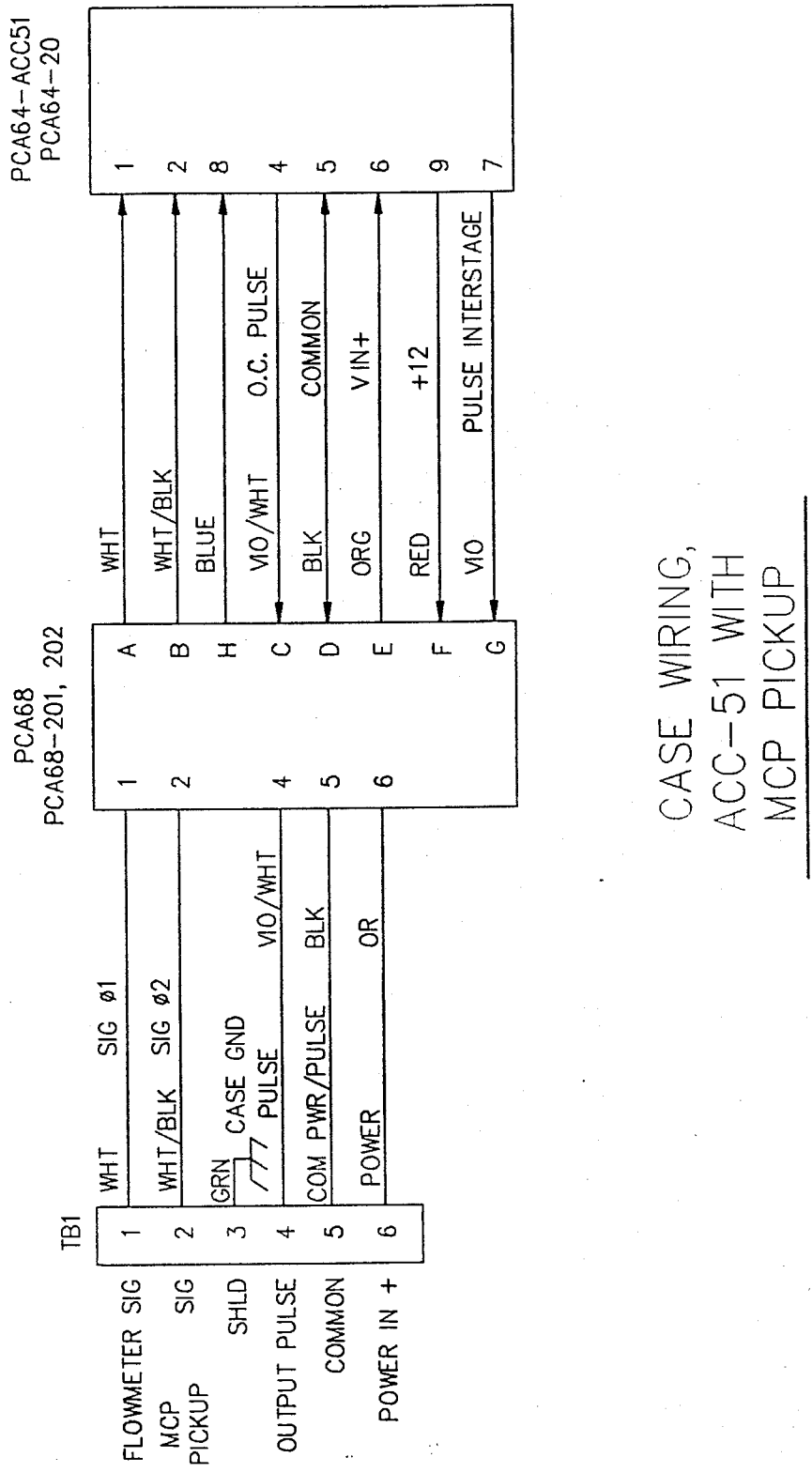

CASE WIRING,
ACC-51 WITH
MCP PICKUP

SIZE	CAGE CODE	DWG NO	REV
A	33321	ACC51-302	A
SCALE	NONE	SHEET	2 OF 2