

# *ACC-96*

## *SIGNAL CONDITIONER*

### *USER'S MANUAL*

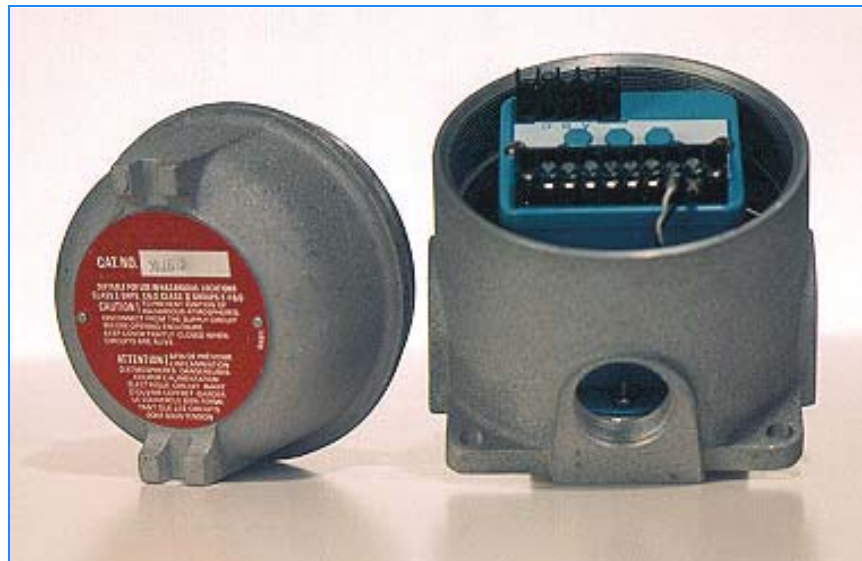

HP-211  
January 2011

**H** **HOFFER FLOW CONTROLS, INC.**  
PERFECTING MEASUREMENT

107 Kitty Hawk Lane, P.O. Box 2145, Elizabeth City, NC 27906-2145  
800-628-4584 252-331-1997 FAX 252-331-2886  
[www.hofferflow.com](http://www.hofferflow.com) E-mail: [info@hofferflow.com](mailto:info@hofferflow.com)



# PREFACE

---

This manual provides all the necessary information to correctly install, operate, maintain and troubleshoot the Model ACC96 frequency to voltage/current converter.

The ACC96 is intended to provide the user with a suitable interface between a frequency generating device and a data acquisition system.

This manual is organized to provide ease of use. Individual sections are provided to cover the Introduction, Installation, Functional Description, Calibration, and Maintenance and Troubleshooting. Illustrations have been used to improve the clarity of information provided in this manual.

This page left intentionally blank

# TABLE OF CONTENTS

PREFACE .....	i
1 INTRODUCTION .....	1
1.1 INTRODUCTION .....	1
1.2 PERFORMANCE CHARACTERISTICS .....	1
1.3 ORDERING INFORMATION .....	3
1.4 WARRANTY .....	4
1.5 ENCLOSURE DETAIL .....	4
1.6 SHIPPING AND HANDLING .....	6
2 INSTALLATION .....	7
2.1 INSTALLATION WIRING .....	7
2.2 INSTALLATION OF THE ACC96 .....	7
3 FUNCTIONAL DESCRIPTION .....	9
3.1 PRINCIPLE OF OPERATION (MAGNETIC PICKUP INPUT TYPE) .....	9
3.2 PRINCIPLE OF OPERATION (MCP PICKUP INPUT TYPE) .....	10
4 CALIBRATION PROCEDURE.....	13
4.1 INTRODUCTION .....	13
4.2 REQUIRED TEST EQUIPMENT .....	13
4.3 CONTROLS AND ADJUSTMENTS .....	13
4.4 PROCEDURE WITH LINEARIZATION OPTION.....	15
4.4.1 CALIBRATION FOR LIQUID SERVICE FLOWMETERS .....	15
4.4.2 FOR CURRENT OUTPUT OPTIONS ONLY .....	16
4.4.3 FOR VOLTAGE OUTPUT OPTION ONLY .....	16
4.5 PROCEDURE WITHOUT LINEARIZATION .....	17
4.5.1 CALIBRATION FOR LIQUID SERVICE FLOWMETERS .....	17
4.5.2 FOR CURRENT OUTPUT OPTIONS ONLY .....	18
4.5.3 FOR VOLTAGE OUTPUT OPTION ONLY .....	18
5 MAINTENANCE .....	19
5.1 INTRODUCTION .....	19
5.2 TROUBLE SHOOTING AND MAINTENANCE.....	19

# LIST OF FIGURES

Figure 1-2 General Purpose Case (Style 2) .....	4
Figure 1-3 Explosion Proof Case (Style 4H/O) .....	5
Figure 1-4 NEMA 4 Case (Style 5) .....	5
Figure 1-5 Explosion Proof Case (Style 4B/O) .....	6
Figure 2.1 Installation Wiring For Magnet Pickup Coil .....	8
Figure 2.2 Installation Wiring For MCP Pickup Coil .....	8
Figure 3.1 Block Diagram for Magnetic Pickup Coil .....	10
Figure 3.2 Block Diagram for MCP Pickup Coil .....	11
Figure 4.1 Control and Adjustment Detail .....	14

This page left intentionally blank

# **1. INTRODUCTION**

---

## **1.1 INTRODUCTION**

---

The Model ACC96 is a multifunction signal conditioner which provides a suitable interface for magnetic or RF coils. Linearization may be accomplished by using the frequency injection method of eliminating the nonlinear transfer characteristic of the Mini Flowmeter Series, and performing linearization for fixed viscous applications..

The output frequency from the Mini Flow Series is linear with respect to flow. However, a plot of frequency versus rate will indicate that the line does not pass through zero. This will result in a K Factor which will vary with the flow rate.

The ACC96 utilizes circuitry which standardizes the K Factor of the Mini Flow Series so that totalizing can be accomplished.

The ACC96 provides a pulse output which is suitable for driving other signal conditioners, indicators or controllers which require a pulse input. The optional analog outputs may be configured as a current or voltage which is suitable for computer interface.

## **1.2 PERFORMANCE CHARACTERISTICS**

---

### **INPUT POWER**

- 115 VAC 60 Hz

### **INPUT**

- Input protected, RF and band pass filtered, adjustable trigger level.
- Input Impedance - 40 kilo ohm (nominal).
- Trigger Sensitivity - 10 millivolt RMS (minimum) 10 Hz to 1000 Hz.
- Over voltage 120 volts RMS absolute (max.).

### **METHOD OF LINEARIZATION**

- Frequency injection of offset frequency with post scaling and low flow alarm.

### **OFFSET FREQUENCY**

- 00.0 to 150.0 Hz.

### **THERMAL STABILITY**

- 200 PPM/°C.

### **LOW FLOW ADJUSTMENT**

- 20 to 200 Hz. (based on comparison with input flowmeter frequency.)

## **1.2 PERFORMANCE CHARACTERISTICS (cont.)**

---

### **CURRENT OUTPUT OPTION**

- Accuracy +/- 0.05% of full scale
- Temperature drift +/-200 PPM/°C.
- Available range 4 to 20 Ma.
- Output suitable for driving floating or grounded loads.
- Maximum loop impedance 375 ohms.
- Response time 0.5 seconds for 10 to 90 %.

### **VOLTAGE OUTPUT OPTION**

- Accuracy +/- 0.05% of full scale
- Temperature drift +/-200 PPM/°C.
- Available range 0 to 5 vdc.
- Impedance less than 10 ohms.
- Response time 0.5 seconds for 10 to 90 %.

### **PULSE OUTPUTS**

- Open Collector Vmos transistor 2N6660. Maximum OFF state voltage 60 VDC. Maximum ON current 1.0 amps.
- TTL/CMOS fanout of 10 TTL/CMOS loads.
- A.C. capacity coupled square wave 5 Vp-p.

### **ENVIRONMENTAL**

- OPERATING: - 20 TO 85°C  
STORAGE: - 65 TO 150°C

### **ENCLOSURES**

- General purpose (standard) case, NEMA-4, Explosion proof.

### 1.3 ORDERING INFORMATION

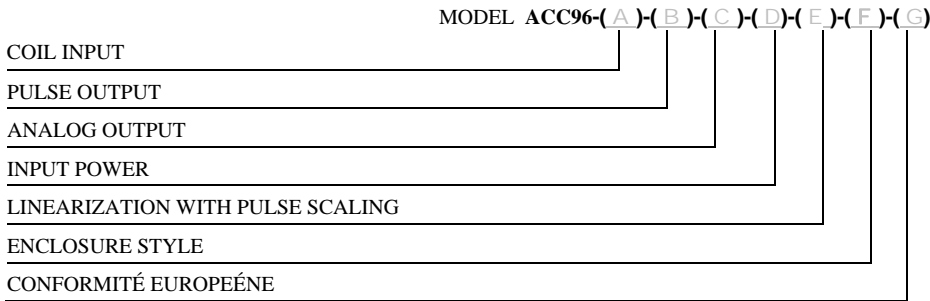

#### COIL INPUT

MODEL ACC96-(A)-( )-( )-( )-( )-( )-( )

##### OPTION ( A )

- (1) MAGNETIC PICKUP
- (2) MC3PA

#### PULSE OUTPUT

MODEL ACC96-( )-(B)-( )-( )-( )-( )-( )

##### OPTION ( B )

- (1) OPEN COLLECTOR
- (2) TTL/CMOS
- (3) AC SQUARE WAVE
- (4) HIGH VOLTAGE PULSE
- (5) 0-10 V SQUARE WAVE

#### ANALOG OUTPUT

MODEL ACC96-( )-( )-(C)-( )-( )-( )-( )

##### OPTION ( C )

- (3) 0-5 VDC
- (7) 4-20 MA

#### INPUT POWER

MODEL ACC96-( )-( )-( )-(D)-( )-( )-( )

##### OPTION ( D )

- (D) 15-35 VDC

#### LINEARIZATION WITH PULSE SCALING

MODEL ACC96-( )-( )-( )-( )-(E)-( )-( )

##### OPTION ( E )

- (L) SWITCH SELECTABLE, DIVIDE BY 2,4,8,16,32,64,128 (BY FACTORY)

**NOTE: THE LINEARIZER IS REQUIRED FOR MINI-FLOWMETERS AND OPTIONAL FOR FIXED VISCOSITIES AND NOT REQUIRED FOR OTHERS.**

#### ENCLOSURE STYLE

MODEL ACC96-( )-( )-( )-( )-( )-(F)-( )

##### OPTION ( F )

- (2H OR 3H) GENERAL PURPOSE ENCLOSURES, (ASSIGNED BY PRODUCTION AND DEPENDENT UPON OPTIONS)
- (4H/O) STYLE 4 CASE, EXPLOSION-PROOF WITH WATER TIGHT 'O' RING  
MEETS CLASS I, GROUP C & D (ADALET XJSD CASE), 2H OR WHEN 3H ADLET XJSD CASE,  
STOCK #200-0760, CLASS II, GROUPS E, F & G, CLASS III

#### CONFORMITÉ EUROPEÉNE

MODEL ACC96-( )-( )-( )-( )-( )-( )-(G)

##### OPTION ( G )

- (CE) CE MARK REQUIRED FOR EUROPE

**NOTE: INSERT (X) IN MODEL NUMBER FOR EVERY OPTION NOT SPECIFIED.**

## 1.4 WARRANTY

---

Hoffer Flow Controls warrants that all equipment will be free from defects in workmanship and material provided that such equipment was properly selected for the service intended, properly installed, and not misused. Equipment which is returned transportation prepaid to Hoffer Flow Controls within 12 months after delivery of goods, or 18 months from date of shipment on equipment for destination outside the United States, and is found by Hoffer Flow Controls inspection to be defective in workmanship or material, will be repaired or replaced at Hoffer Flow Controls sole option, free of charge and returned shipped using the lowest cost transportation prepaid.

In the event of product failure contact Hoffer Flow Controls at 252-331-1997 or 800-628-4584, for issuance of a **Returned Material Authorization (RMA)** number.

## 1.5 ENCLOSURE DETAIL

---

The ACC96 is may be packaged in either the General Purpose case (Style 1), in an Explosion Proof case (Style 4), or in the NEMA 4 case (style 5). Dimensions are given in Figures 1-2, 1-3, and 1-4.

**Figure 1-2 General Purpose Case (Style 2)**

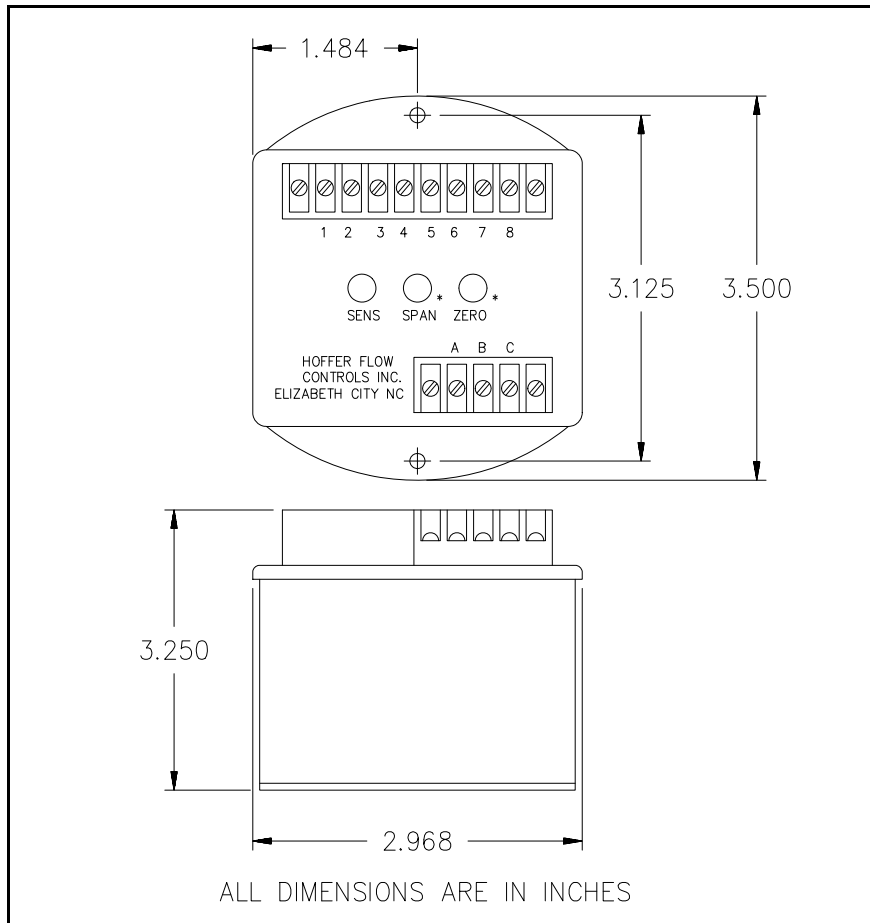

**Figure 1-3 Explosion Proof Case (Style 4H/O)**

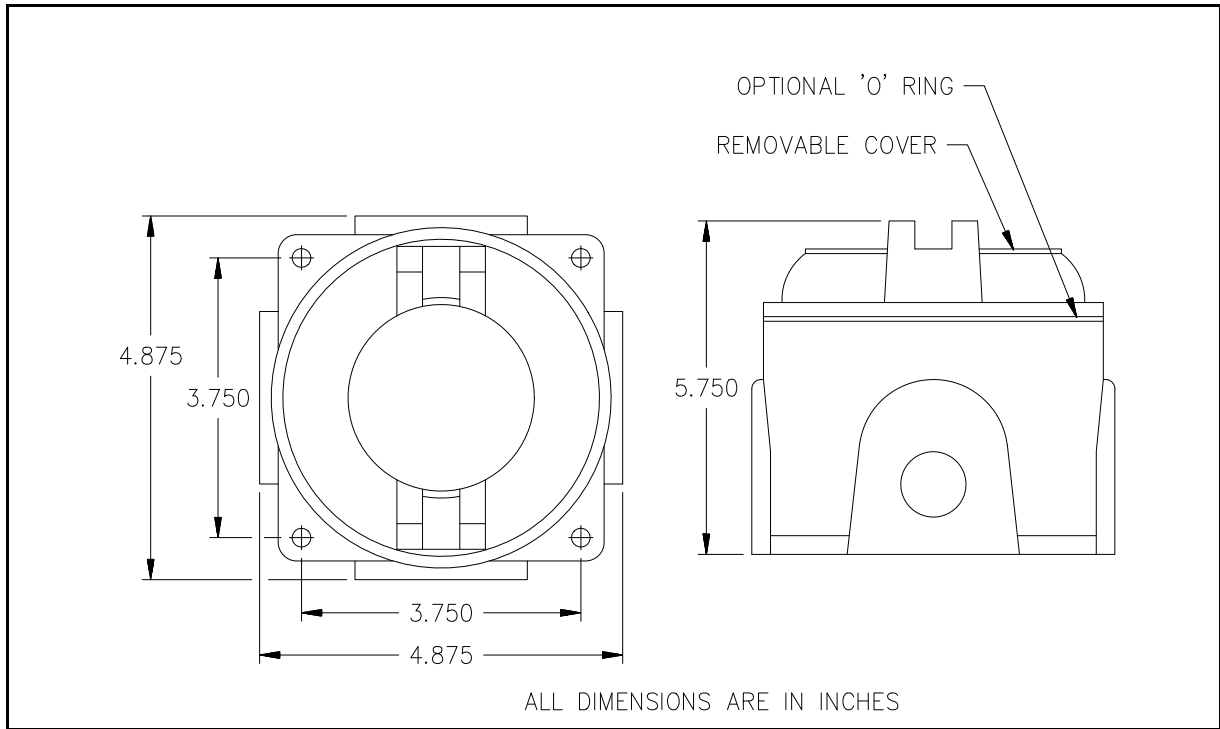

**Figure 1-4 NEMA 4 Case (Style 5)**

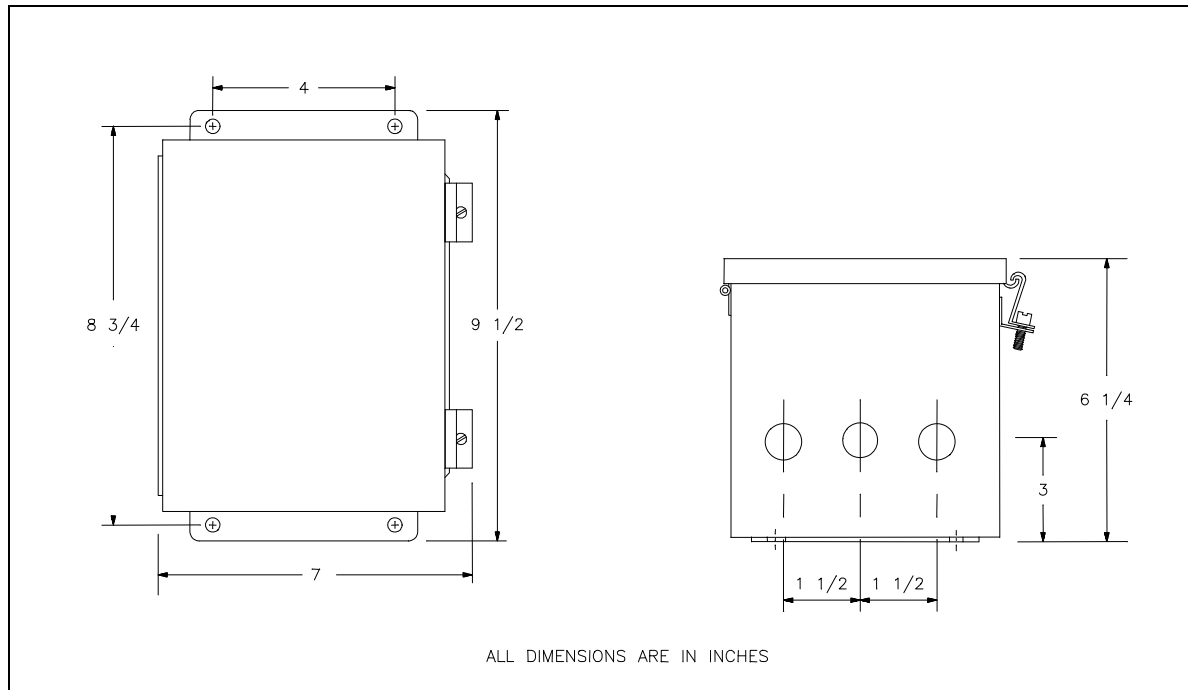

**Figure 1-5 Explosion Proof Case (Style 4B/O)**

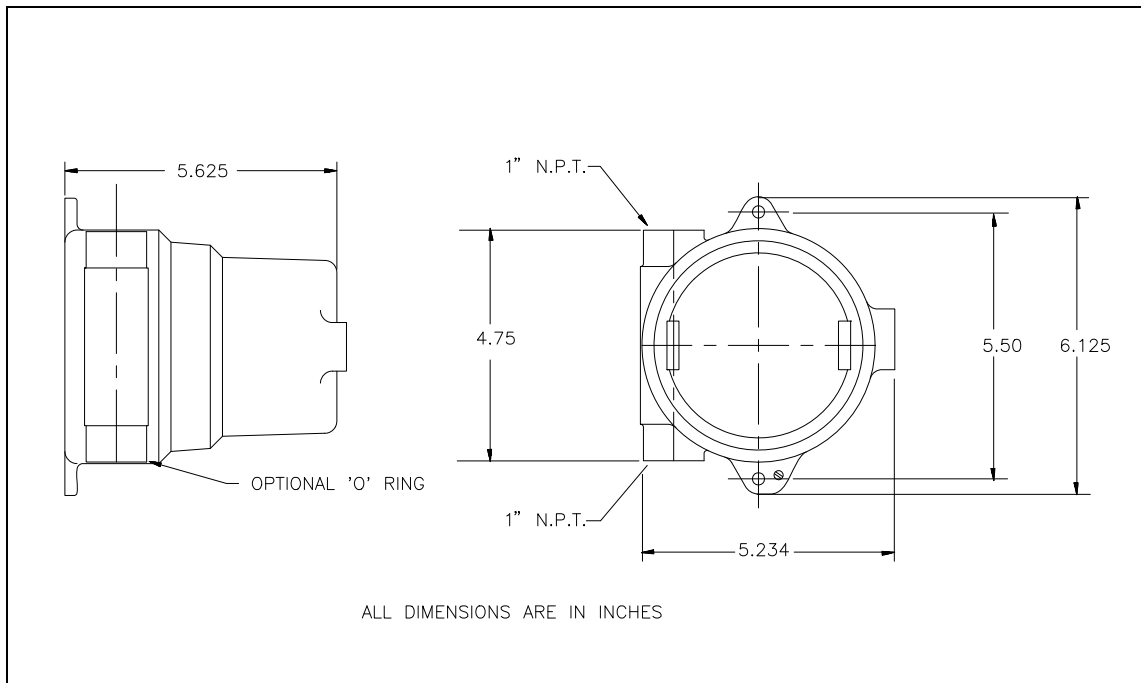

## **1.6 SHIPPING AND HANDLING**

---

***CAUTION - The ACC96 is a static-sensitive device and standard practice for static sensitive parts should be observed.***

---

In the event of malfunctioning equipment the following guidelines should be observed for the preparation and shipment of the equipment. Failure to do so may result in the material reaching its destination damaged.

The electronic unit due to its **STATIC SENSITIVE** nature should be wrapped in a material conforming to MIL-B-81705 , Type II, and packaged in a heat sealable bag conforming to MIL-P-81997. These steps are necessary to protect the equipment from electrostatic charge(s) that may occur during handling.

The package should then be marked with a sensitive electronic device caution label conforming to MIL-STD-129, Appendix C. The equipment should then be wrapped in cushioning material, and placed into a close fitting box conforming to PPP-B-636 Domestic class.

The exterior shipping container should be marked with a sensitive electronic device caution label conforming to MIL-STD-129, Appendix C.

Clearly mark the factory provided RMA number on all paperwork and shipping packaging.

## **2 INSTALLATION**

---

### **2.1 INSTALLATION WIRING**

---

In considering the interconnections between the flowmeter and the flow measurement system some attention must be given to anticipated noise sources and to the coupling of these noise sources to the interconnecting wiring.

Noise signals may be coupled inductively or capacitively into the wiring between the flowmeter and the electronic measuring systems. In general, utilizing a shielded, twisted pair for the interconnection greatly reduces this coupling. The shield should be grounded on one end of the cable only. In general, grounding only on the electronic measuring system is best.

However, even with proper interconnecting cabling cross talk with other signal lines or power lines may still occur and should be avoided. Physical isolation in the manner in which the wiring is run reduces the chance of potential problems.

It is common to transmit the low level output signal from a magnetic type pickup coil several hundred feet through a shielded, twisted pair instrument cable. In the event that a Modulated Carrier Pickup (MCP) the signal conditioner should be located no more than 100 feet away. In either case, where a noisy environment is suspected, it is recommended that a signal conditioner be installed on or near the flowmeter to the electronic measuring system. Suitable accessory models are available from manufacturer.

### **2.2 INSTALLATION OF THE ACC96**

---

The Model ACC96 should be placed in a convenient location which maintains access to the unit should repairs or readjustments be required.

Refer to installation Figure 2.1 thru 2.2 for the appropriate configuration and the appropriate terminals for interconnecting. Connections to the terminal block should be carefully dressed to avoid having bare wires extend past the screw clamp on the terminal block. Wires should be neatly dressed near the bottom of the enclosure to prevent problems when the cover is installed.

Connect two conductor shielded cable from the flowmeter to terminal block TB1 terminals 1 and 2. Connect the shield to terminal block TB1 terminal 3.

If the unit is configured for 15 to 35 VDC power, (refer to model number for power option ordered), connect the power wiring to terminal block TB2. Connect to terminal A positive voltage supply, to terminal B connect the negative voltage supply, and to terminal C connect the earth or chassis lead.

The output signal from the ACC96 may be either a pulse output or analog output, or both pulse and analog outputs. For the pulse output connect to terminal block TB1 terminal 6 for pulse signal and terminal 7 for pulse common. For the analog output connect to terminal block TB1 terminal 4 for output signal and terminal 5 for signal common.

**Figure 2.1 Installation Wiring For Magnet Pickup 15 to 35 VDC**

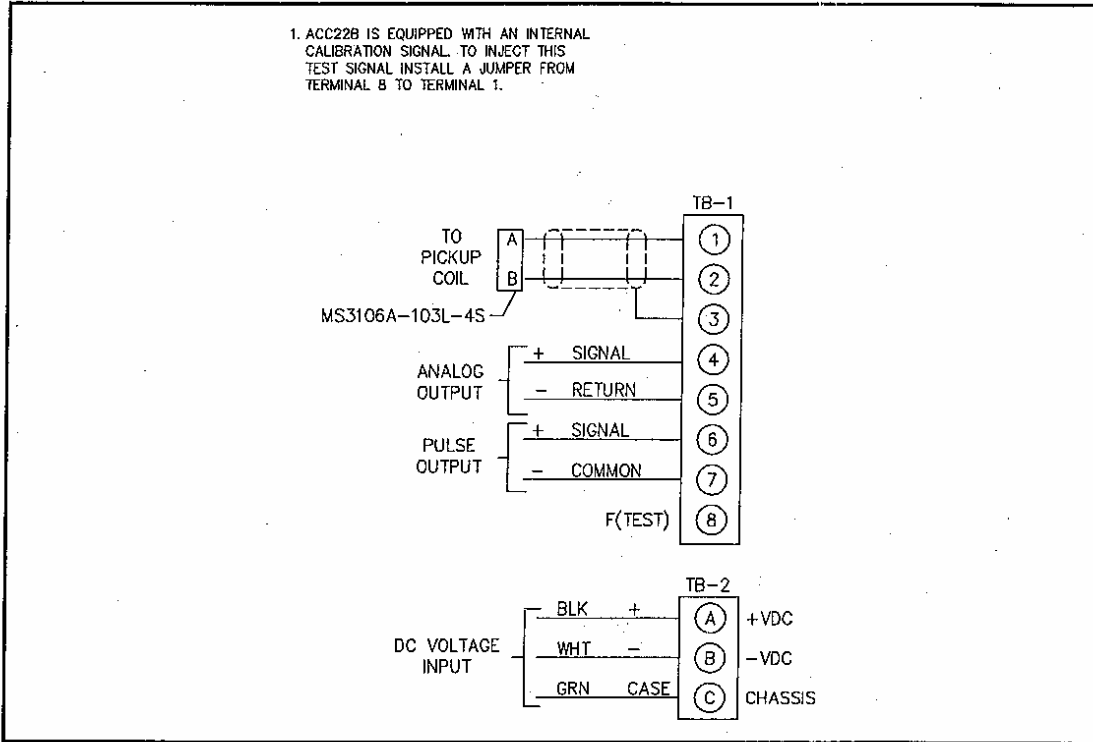

**Figure 2.2 Installation Wiring With MCP Coil 15 to 35 VDC**

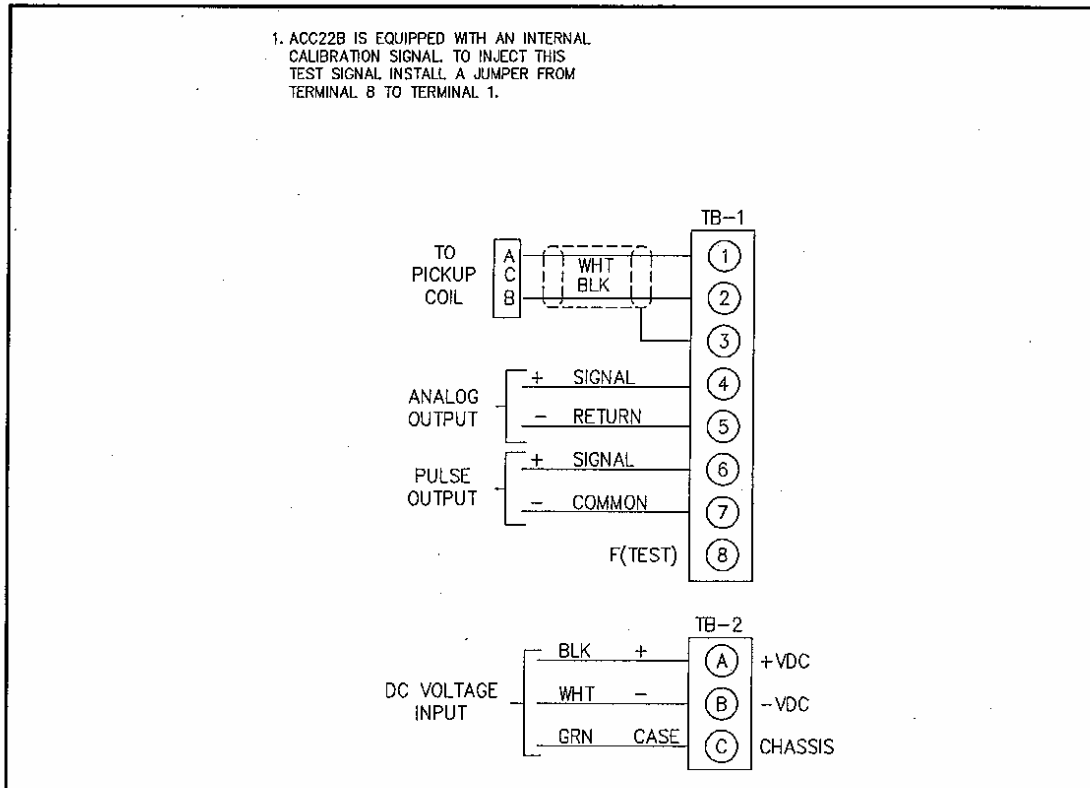

## 3 FUNCTIONAL DESCRIPTION

---

### 3.1 PRINCIPLE OF OPERATION (MAGNETIC PICKUP INPUT TYPE)

---

A simplified block of the ACC96 Mini Flow Linearizer is given on drawing Figure 3.1. The basic operation of the system is as follows.

The frequency signal from the flowmeter is connected to the ACC96 with a twisted pair shielded cable. The signal enters through the Sensitivity control which is used to reject unwanted noise by raising the trigger threshold above the background noise present.

The low level flowmeter signal is then passed through a special conditioning chain where it is filtered, amplified and shaped into a train of digital pulses whose frequency is non linearly related to the volume flow rate.

If Linearization is equipped the digital pulse train is then passed through the linearizer where the offset frequency signal is injected into it. For flow rates within the range of the meter, the linearizer output will be linearly related to the volumetric flow rate. In addition, this circuitry drives the 'low flow' out of range cut out circuit which effectively turns off the offset oscillator based on the setting of the cut out circuit.

The signal entering the frequency to analog converter is passed through a combination of divide by N and DIP switch matrix. The output is chosen whose pulse rate is between 75 and 150 Hz at the maximum flow rate to be measured. This scaled pulse rate is fed into a precision monostable circuit. The output of the monostable is then filtered into an analog voltage that is proportional to flow.

The output amplifier will take this voltage and perform either a voltage to voltage amplifier or voltage to current amplifier.

If Linearization is equipped, the output is divided by 8 to reduce irregular pulses spacing. Then the pulse train enters a buffer and an attenuator simultaneously. The buffer output produces a square wave pulse which can be used as a CMOS/TTL compatible output. The attenuator produces a capacitor coupled AC output which is suitable for driving other signal conditioners, indicators or controllers which require an AC signal input.

The power supply takes the available input power, 15 to 35 VDC voltage and provides the power required by the various circuitry.

A stable oscillator is provided which generates a 120 Hz test signal which may be used to perform tests on the ACC96.

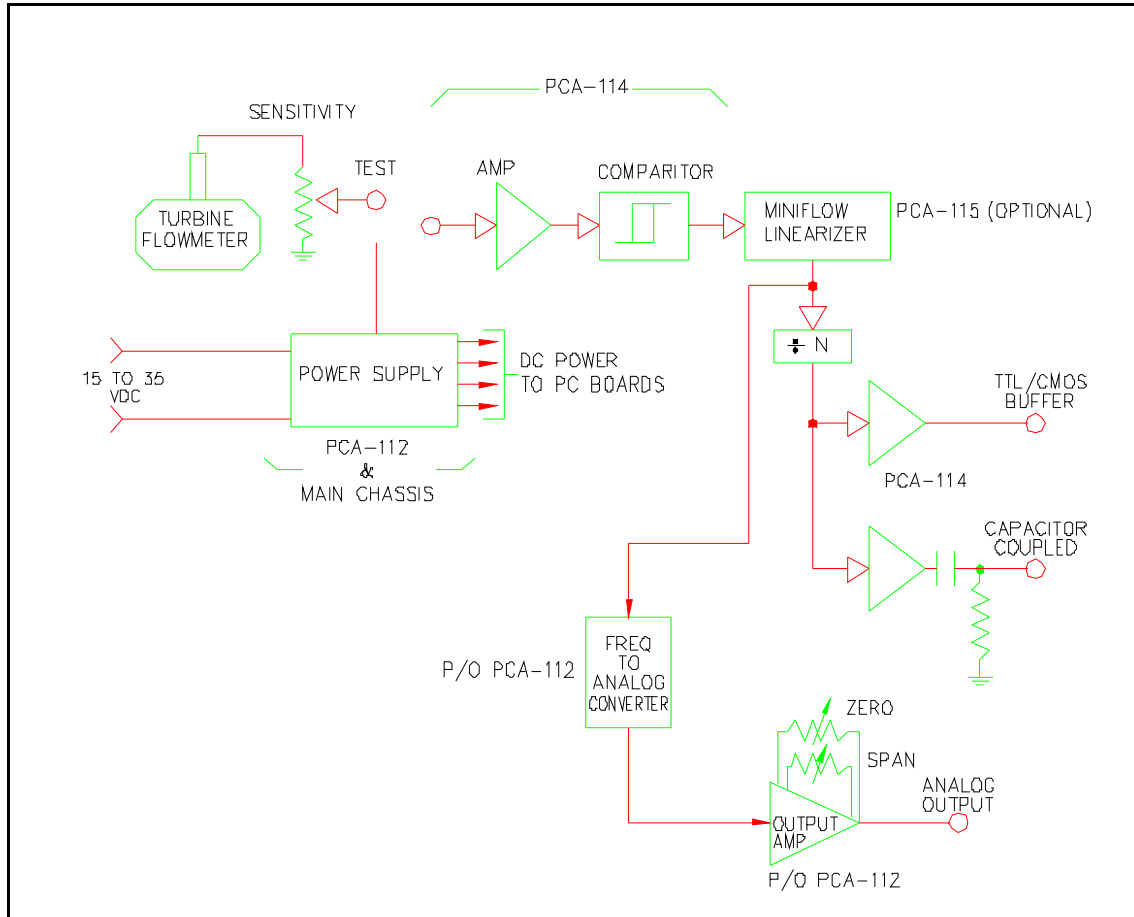

**Figure 3.1 Block Diagram Magnetic Pickup Coil**

### 3.2 PRINCIPLE OF OPERATION (MCP PICKUP INPUT TYPE)

A simplified block diagram of Modulated Carrier Conditioner/Converter is given in drawing Figure 3.2. Key functional blocks, as well as, information flow are designated. The basic operation of the system is as follows:

The MCP on the turbine flowmeter is connected to the Model ACC96 with a shielded twisted pair signal cable. The MCP pickup coil forms part of an oscillator circuit and is excited by the ACC96. Motion of the turbine rotor modulates the oscillator output. A demodulator converts the AM signal to a single frequency determined by the rotor speed. The low level demodulated signal is then passed through a signal conditioning chain where it is filtered, amplified and shaped into a train of digital pulses whose frequency is related to the volume flow rate and where each pulse represents a discrete volume of fluid.

The digital pulse train is passed through the linearizer where the offset frequency signal is injected into it. For flow rates within the range of the meter, the linearizer output will be linearly related to the volumetric flow rate. In addition, this circuitry drives the "low flow" out of range cut out circuit which effectively turns off the offset oscillator based on the setting of the cut out circuit.

The signal entering the frequency to analog converter is passed through a combination of divide by N and DIP switch matrix. The output pulse rate is chosen to be between 75 and 150 Hz at the maximum flow rate to be measured. This scaled pulse rate is a precision monostable circuit. The output of the monostable is then filtered into an analog voltage that is proportional to flow.

Finally, the output is divided by 8 to reduce irregular pulses spacing. Then the pulse train enters a buffer and an attenuator simultaneously. The buffer output produces a square wave pulse which can be used as a CMO/TTL compatible output. The attenuator produces a capacitors or controllers which require an AC signal input.

The power supply takes the available input power, 15 to 35 VDC voltage and provides the power required by the various circuitry.

A stable oscillator is provided which generates a 120 Hz test signal which may be used to perform tests on the ACC96.

**Figure 3.2 Block Diagram for MCP Pickup Coil**

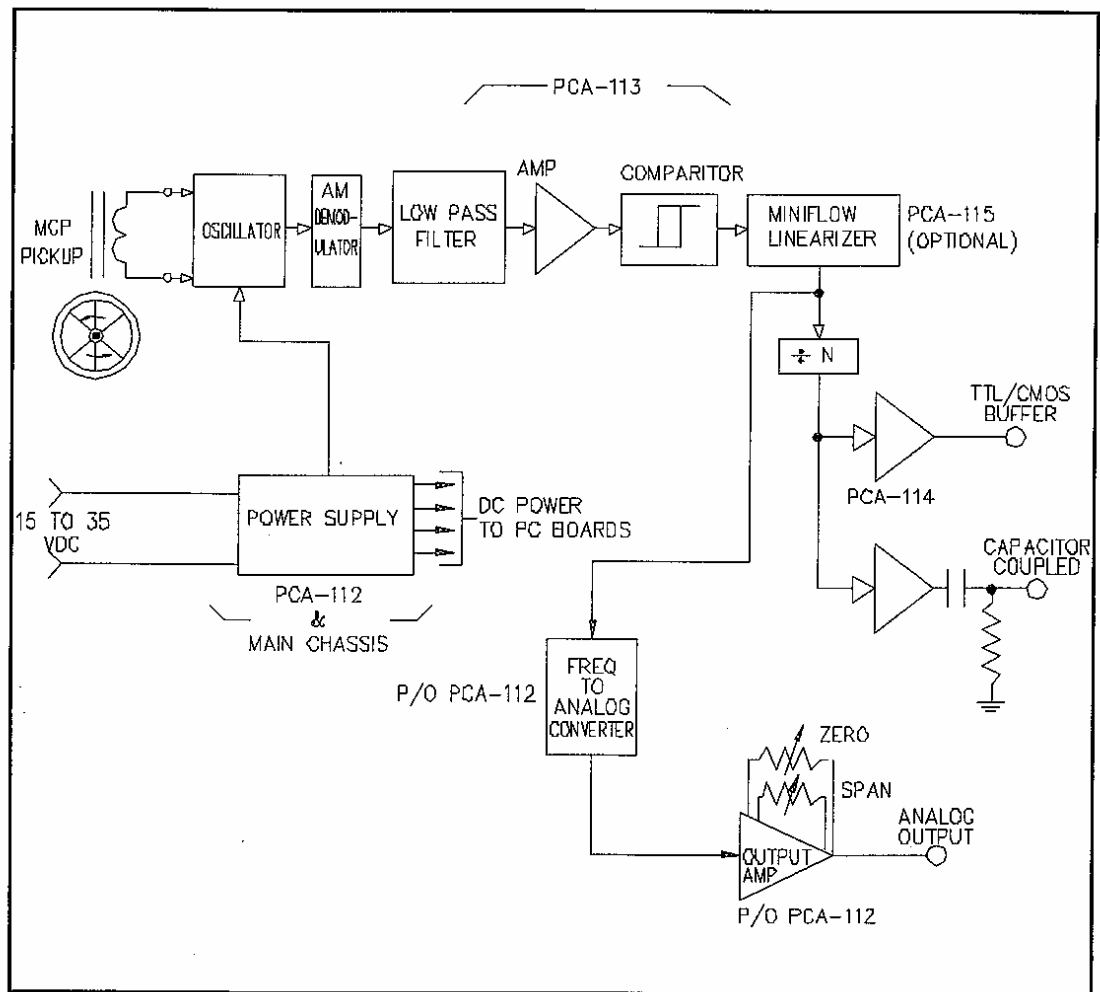

This page left intentionally blank

# 4 CALIBRATION PROCEDURE

---

## 4.1 INTRODUCTION

---

In general, all flow measurement systems supplied by Hoffer Flow Controls have been factory calibrated as specified by the user, at the time of purchase.

All systems which under went such a factory calibration have a calibration card attached prior to shipment. This card contains the flow rate, offset frequency and low flow set point.

Field calibration is only required when a change has occurred. Such a change may be due to repair, replacement or recalibration of the flowmeter.

## 4.2 REQUIRED TEST EQUIPMENT

---

In order to perform field calibration and troubleshoot the ACC96 the following suggested equipment list is provided.

MANUFACTURER	PART NUMBER	DESCRIPTION
Fluke	8060A	True RMS Multimeter
Simpson	420	Function Generator
Viz	WD-755	Multi Function Counter
Spectrol	8-TOOO	Adjustment Tool

## 4.3 CONTROLS AND ADJUSTMENTS

---

- SENSITIVITY** A twenty turn control used to set the threshold sensitivity level above the ambient noise pickup.
- SPAN** A twenty turn adjustment which is used to set current/voltage output to the desired span corresponding to the equivalent flow range. (i.e., 20 mA or 5 VDC corresponding to 0-100 GPM).
- ZERO** A twenty turn adjustment which is used to set the current/voltage output signal to the desired zero value. (i.e., 4mA or 0VDC at zero GPM).
- RANGE SELECT** A dual in line (DIP) switch which is located on the PCA-112 board, which is used to program the input frequency range.
- PULSE SCALER** If Linearization is equipped, a dual in line (DIP) switch located on either the PCA-114 or PCA-115, which is used in programming the desired pulse output scaler of ÷ 1, 2, 4, 8, 16, 32, 64, or 128. Unit shipped with ÷ 8 as standard.

### 4.3 CONTROLS AND ADJUSTMENTS (cont.)

**RANGE SELECT** A dual in line (DIP) switch located on the PCA-112, which is used in programming the module to accept an input frequency range.

**OFFSET FREQ. ADJ** An internal 20 turn adjustment on the PCA-115, which is used adjust the equivalent offset frequency of the flowmeter. Adjustment range is 0.00 to 150.0 Hz.

**Figure 4.1 Control and Adjustment Detail**

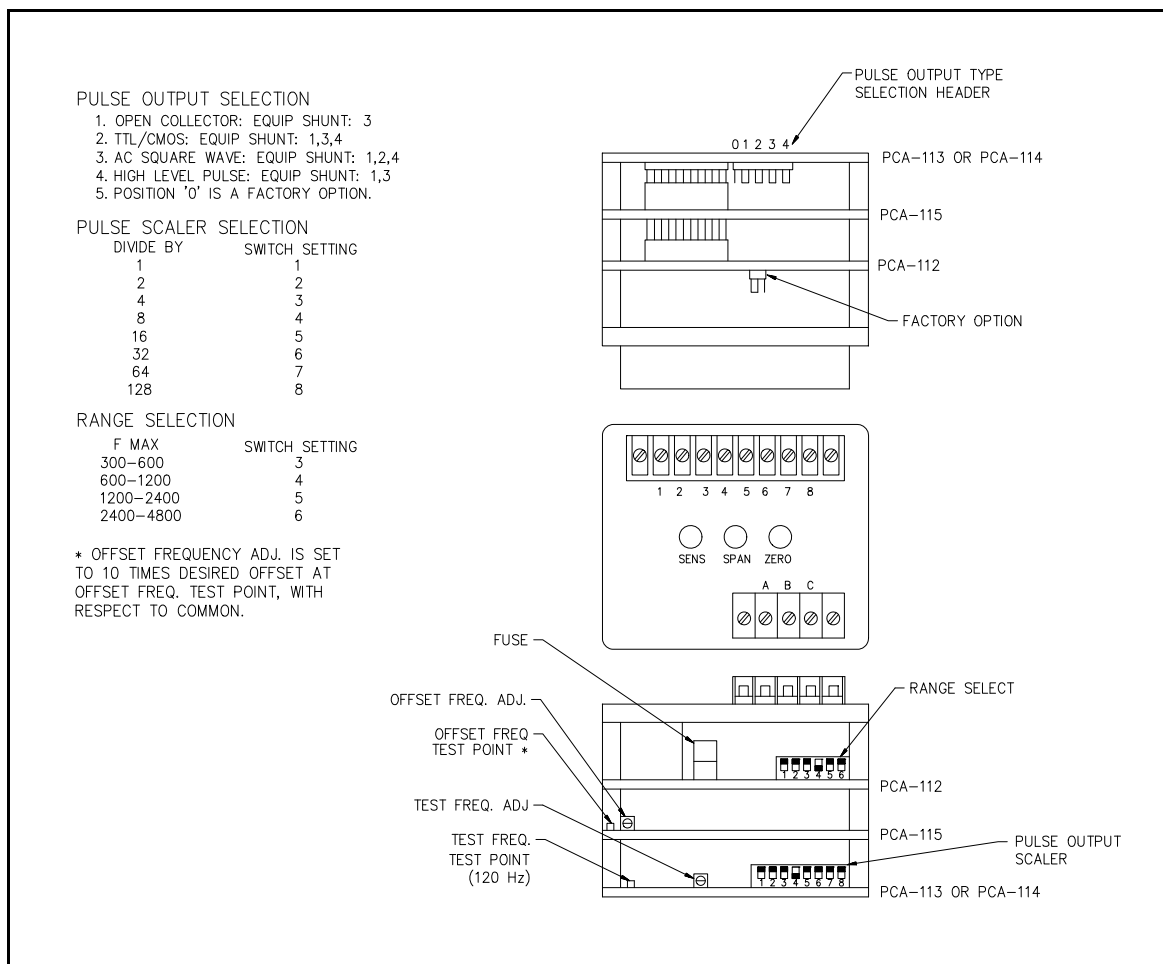

## 4.4 PROCEDURE WITH LINEARIZATION OPTION

---

Begin by determining the offset frequency of the mini flowmeter. This is supplied on the calibration sheet, term this F(OS).

The mini flow linearizer may be calibrated with the internal TEST frequency or an external oscillator used in conjunction with a frequency counter.

The internal test signal, when jumpered to the input terminal, injects an internally generated frequency. When using this feature, F (TEST) is equal to 120 Hz.

The expected output frequency can be calculated by the following equation:

$$F_{(OUT)} = \frac{1}{8} X [ F_{TEST} + F_{OS} ]$$

Where: FOUT is the expected output frequency.  
FTEST is the test frequency used.  
FOS is the offset frequency.

Connect frequency counter to the offset frequency test point and observe that the frequency equals 10 X F (OS).

Connect frequency counter to the output of the unit and with an injected TEST frequency, verify that the output frequency equals equation 1.

### 4.4.1 CALIBRATION FOR LIQUID SERVICE FLOWMETERS

The ACC96 may be calibrated with an internal "TEST" frequency or an external oscillator used in conjunction with a frequency counter.

The "TEST" frequency is jumpered to the input, injects an internally generated frequency into the unit. When using this feature, F(TEST) is equal to 120 Hz and is used in the following equations.

An external oscillator may be used to supply a test frequency. In this method, the external oscillator is connected to the signal input terminals. The oscillator's output frequency is set to equal F(MAX) as indicated on the frequency counter. For this approach use F(MAX) in the following equations for F(TEST).

Regardless of the method used, begin by calculating the following setpoints indicated by Equation 1 through Equation 3. Use the frequency F(TEST) depending on calibration method chosen above.

Equation 1: 
$$F(\text{MAX}) = \left[ \frac{K \text{ FACTOR} \times R(\text{MAX})}{60} \right] - F(\text{OS})$$

Equation 2: 
$$\text{Set}(\text{ZERO}) = \begin{array}{l} \text{SET TO NO FLOW CONDITION} \\ \text{i.e., 4mA, or OV} \end{array}$$

Equation 3: 
$$\text{Set}(\text{SPAN}) = \frac{(F(\text{TEST}) + F(\text{OS})) \times \text{SPAN}}{(F(\text{MAX}) + F(\text{OS}))} + \text{ZERO}$$

Where: F(TEST) is test frequency used.

F(OS) is offset frequency.

F(MAX) is the flowmeter output frequency at R(MAX) when at the reference condition at which the relation with F(MAX) was defined.

K-Factor is in units of readout, i.e. PULSE/GAL.

R(MAX) is the maximum flowrate of the flowrate of the flowmeter.

SPAN is varying component of analog output i.e. 16mA for 4 to 20mA output 5V for 0 to 5V output.

The Range Adjustment is accomplished by selecting a switch position on a “DIP” switch located on the PCA-112 printed circuit card depending upon the model. See Table 4-1 to determine required switch position, select switch position as shown on drawing ACC96.

Turn the “SPAN” control fully counter-clockwise until slippage is felt or 25 turns.

**Table 4-1 Range Select**

F(MAX)	RANGE SELECT SWITCH POSITION
300 to 600	3
600 to 1200	4
1200 to 2400	5
2400 to 4800	6

#### **4.4.2 FOR CURRENT OUTPUT OPTIONS ONLY**

Connect a digital milliampmeter or equivalent, across the current output terminals.

Adjust “Zero” control for desired “Zero” current (i.e. 4mA).

Inject the test frequency while adjusting “SPAN” for current equal to SET (SPAN).

Iterate above steps until no change is observed.

#### **4.4.3 FOR VOLTAGE OUTPUT OPTION ONLY**

Connect a digital voltmeter across the voltage output terminals.

Adjust “Zero” control for desired “Zero” current (i.e. 0volts).

Inject the test frequency while adjusting “SPAN” for voltage equal to SET (SPAN).

Iterate above steps until no change is observed.

## 4.5 PROCEDURE WITHOUT LINEARIZATION

---

The acc96 may be calibrated with the internal TEST frequency or an external oscillator used in conjunction with a frequency counter.

The internal test signal, when jumpered to the input terminal, injects an internally generated frequency. When using this feature, F (TEST) is equal to 120 Hz.

The expected output frequency can be calculated by the following equation:

$$F_{(OUT)} = F_{TEST}$$

Where: FOUT is the expected output frequency.  
FTEST is the test frequency used.

Connect frequency counter to the output of the unit and with an injected TEST frequency, verify that the output frequency equals equation 1.

### 4.5.1 CALIBRATION FOR LIQUID SERVICE FLOWMETERS

The ACC96 may be calibrated with an internal “TEST” frequency or an external oscillator used in conjunction with a frequency counter.

The “TEST” frequency is jumpered to the input, injects an internally generated frequency into the unit. When using this feature, F(TEST) is equal to 120 Hz and is used in the following equations.

An external oscillator may be used to supply a test frequency. In this method, the external oscillator is connected to the signal input terminals. The oscillator's output frequency is set to equal F(MAX) as indicated on the frequency counter. For this approach use F(MAX) in the following equations for F(TEST).

Regardless of the method used, begin by calculating the following setpoints indicated by Equation 1 through Equation 3. Use the frequency F(TEST) depending on calibration method chosen above.

Equation 1: 
$$F(\text{MAX}) = \left[ \frac{K \text{ FACTOR} \times R(\text{MAX})}{60} \right]$$

Equation 2: 
$$\text{Set}(\text{ZERO}) = \frac{\text{SET TO NO FLOW CONDITION}}{\text{i.e., 4mA, or OV}}$$

Equation 3: 
$$\text{Set}(\text{SPAN}) = \frac{F(\text{TEST}) \times \text{SPAN}}{F(\text{MAX})} + \text{ZERO}$$

Where: F(TEST) is test frequency used.

F(MAX) is the flowmeter output frequency at R(MAX) when at the reference condition at which the relation with F(MAX) was defined.

K-Factor is in units of readout, i.e. PULSE/GAL.

R(MAX) is the maximum flowrate of the flowrate of the flowmeter.

SPAN is varying component of analog output i.e. 16mA for 4 to 20mA output 5V for 0 to 5V output.

The Range Adjustment is accomplished by selecting a switch position on a “DIP” switch located on the PCA-112 printed circuit card depending upon the model. See Table 4-1 to determine required switch position, select switch position as shown on drawing ACC96.

Turn the “SPAN” control fully counter-clockwise until slippage is felt or 25 turns.

**Table 4-2 Range Select**

F(MAX)	RANGE SELECT SWITCH POSITION
75 to 150	1
150 to 300	2
300 to 600	3
600 to 1200	4
1200 to 2400	5
2400 to 4800	6

**4.5.2 FOR CURRENT OUTPUT OPTIONS ONLY**

Connect a digital milliammeter or equivalent, across the current output terminals.

Adjust “Zero” control for desired “Zero” current (i.e. 4mA).

Inject the test frequency while adjusting “SPAN” for current equal to SET (SPAN).

Iterate above steps until no change is observed.

**4.5.3 FOR VOLTAGE OUTPUT OPTION ONLY**

Connect a digital voltmeter across the voltage output terminals.

Adjust “Zero” control for desired “Zero” current (i.e. 0volts).

Inject the test frequency while adjusting “SPAN” for voltage equal to SET (SPAN).

Iterate above steps until no change is observed.

# 5 MAINTENANCE

---

## 5.1 INTRODUCTION

---

HOFFER FLOW CONTROLS Flow Measurement Systems are constructed to give a long service life in the targeted measuring field and service environment. However, problems do occur from time to time and the following points should be considered for preventive maintenance and repairs.

A spare Parts List has been provided which, at the discretion of the user, may be user stocked. Consult with the manufacturer if an abridged spare parts list is sought. The recommended spare parts list may be found following this section and in the users manual for the flowmeter.

In case the flow measurement system malfunctions or becomes inoperative, a trouble shooting procedure is enclosed.

Factory consultation is available to assist in diagnosing problems. In addition, factory repair parts and service are available for individuals who wish to utilize this service.

## 5.2 TROUBLE SHOOTING AND MAINTENANCE

---

- \* **ALL PRINTED CIRCUIT CARDS ARE UNDER WARRANTY FOR ONE YEAR AFTER DATE OF SALE.**
- \* **ALL PRINTED CIRCUIT CARDS MAY BE FACTORY REPAIRED AT A NOMINAL FEE FOR PARTS AND LABOR AFTER WARRANTY PERIOD.**

In case of an inoperable or malfunctioning system the following procedures can be used to isolate the faulty wiring, printed circuit boards and/or alternate causes. The majority of repairs can be made in the field thereby reducing the time a unit is out of service.

A recommended spare parts list is given immediately following the trouble shooting portion of this manual. The necessary documentation is contained within this manual with the exception of the calibration data sheet for the turbine flowmeter. This calibration is supplied separately.

Factory consultation is available to assist in diagnosing problems. Note that in some cases factory repairs can be performed more easily than can be accomplished in the field.

To test the ACC-96 an internal 120 Hz test frequency has been provided. Failure conditions are listed and the possible corrective actions given to eliminate the observed problem.

OBSERVED CONDITION	CORRECTIVE ACTION
<ul style="list-style-type: none"> <li>• UNIT REPEATEDLY BLOWS FUSES.</li> </ul>	<ul style="list-style-type: none"> <li>• INSPECT TERMINAL STRIP WIRING FOR CONFORMITY TO THE INSTALLATION INSTRUCTIONS AND FOR ACCEPTABLE WORKMANSHIP.</li> <li>• VERIFY CORRECT FUSE SIZE.</li> <li>• REPLACE PCA-112.</li> <li>• REPLACE PCA-115.</li> <li>• REPLACE PCA-113 OR PCA-114.</li> </ul>
	<p>NOTE: IF UNIT CONTINUES TO BLOW FUSES, IT IS ADVISABLE TO RETURN IT TO THE FACTORY. THIS DEFECT IS DIFFICULT TO DIAGNOSE IN AN ASSEMBLED SYSTEM.</p>
<ul style="list-style-type: none"> <li>• UNIT GIVES NO PULSE OUTPUT WITH FLOW PRESENT.</li> </ul>	<ul style="list-style-type: none"> <li>• TURN SENSITIVITY POTENTIOMETER CLOCKWISE.</li> <li>• REPLACE PICKUP COIL AND/OR INTERCONNECTING WIRING.</li> <li>• REPLACE PCA-113 OR PCA-114.</li> <li>• REPLACE PCA-115.</li> <li>• REPLACE PCA-112.</li> </ul>

OBSERVED CONDITION	CORRECTIVE ACTION
<ul style="list-style-type: none"> <li>• UNIT GIVES PULSE OUTPUT WITH NO FLOW PRESENT.</li> </ul>	<ul style="list-style-type: none"> <li>• NOISE PICKUP, TURN SENSITIVITY ADJUST COUNTER CLOCKWISE UNTIL CORRECT ZERO FLOW INDICATION IS OBTAINED.</li> <li>• REPLACE PICKUP COIL.</li> <li>• REPLACE PCA-115.</li> <li>• REPLACE PCA-113, OR PCA-114.</li> </ul>
<ul style="list-style-type: none"> <li>• UNIT DOES NOT FUNCTION.</li> </ul>	<ul style="list-style-type: none"> <li>• PCA-115 HAS INCORRECT OFFSET FREQUENCY SETTING.</li> <li>• REPLACE PCA-115.</li> <li>• FLOWMETER USED BELOW OR ABOVE NORMAL RANGE. OBTAIN CORRECT FLOWMETER.</li> </ul>
<ul style="list-style-type: none"> <li>• ANALOG OUTPUT.</li> </ul>	<ul style="list-style-type: none"> <li>• REPLACE PCA-112.</li> </ul>
<ul style="list-style-type: none"> <li>• ANALOG OUTPUT WITH NO FLOW</li> </ul>	<ul style="list-style-type: none"> <li>• TURN SENSITIVITY SLOWLY CCW.</li> <li>• REPLACE PCA-112.</li> </ul> <p>NOTE: FULLY CCW WILL MAKE UNIT INOPERATIVE.</p>