

ACE-P8
For Use with ICE, ACEII and ACE-B
Advanced Cryogenic Electronics

USER'S MANUAL



HP-314
November 2009

H **HOFFER FLOW CONTROLS, INC.**
PERFECTING MEASUREMENT™

107 Kitty Hawk Lane • P.O. Box 2145 • Elizabeth City, NC 27906-2145
1-800-4584 • 252-331-1997 • FAX: 252-331-2886
www.hofferflow.com • E-mail: info@hofferflow.com

NOTICE

HOFFER FLOW CONTROLS, INC. makes no warranty of any kind with regard to this material, including, but not limited to, the implied warranties of merchantability and fitness for a particular purpose.

This manual has been provided as an aid in installing, connecting, calibrating, operating, and servicing this unit. Every precaution for accuracy has been taken in the preparation of this manual; however, HOFFER FLOW CONTROLS, INC. neither assumes responsibility for any omissions or errors that may appear nor assumes liability for any damages that may result from the use of the products in accordance with information contained in the manual.

HOFFER FLOW CONTROLS' policy is to provide a user manual for each item supplied. Therefore, all applicable user manuals should be examined before attempting to install or otherwise connect a number of related subsystems.

During installation, care must be taken to select the correct interconnecting wiring drawing. The choice of an incorrect connection drawing may result in damage to the system and/or one of the components.

Please review the complete model number of each item to be connected and locate the appropriate manual(s) and/or drawing(s). Identify all model numbers exactly before making any connections. A number of options and accessories may be added to the main instrument, which are not shown on the basic user wiring. Consult the appropriate option or accessory user manual before connecting it to the system. In many cases, a system wiring drawing is available and may be requested from HOFFER FLOW CONTROLS.

This document contains proprietary information, which is protected by copyright. All rights are reserved. No part of this document may be photocopied, reproduced, or translated to another language without the prior written consent of HOFFER FLOW CONTROLS, INC.

HOFFER FLOW CONTROLS' policy is to make running changes, not model changes, whenever an improvement is possible. This affords our customers the latest in technology and engineering. The information contained in this document is subject to change without notice.

Return Requests / Inquiries

Direct all warranty and repair requests/inquiries to the Hoffer Flow Controls Customer Service Department, telephone number (252) 331-1997 or 1-800-628-4584. **BEFORE RETURNING ANY PRODUCT(S) TO HOFFER FLOW CONTROLS, PURCHASER MUST OBTAIN A RETURNED MATERIAL AUTHORIZATION (RMA) NUMBER FROM HOFFER FLOW CONTROLS' CUSTOMER SERVICE DEPARTMENT (IN ORDER TO AVOID PROCESSING DELAYS).** The assigned RMA number should then be marked on the outside of the return package and on any correspondence.

FOR **WARRANTY** RETURNS, please have the following information available BEFORE contacting HOFFER FLOW CONTROLS:

1. P.O. number under which the product was PURCHASED,
2. Model and serial number of the product under warranty, and
3. Repair instructions and/or specific problems relative to the product.

FOR **NON-WARRANTY** REPAIRS OR CALIBRATIONS, consult HOFFER FLOW CONTROLS for current repair/ calibration charges. Have the following information available BEFORE contacting HOFFER FLOW CONTROLS:

1. P.O. number to cover the COST of the repair/calibration,
2. Model and serial number of the product and
3. Repair instructions and/or specific problems relative to the product.

LIMITED WARRANTY

HOFFER FLOW CONTROLS, INC. ("HFC") warrants HFC's products ("goods") described in the specifications incorporated in this manual to be free from defects in material and workmanship under normal use and service, but only if such goods have been properly selected for the service intended, properly installed and properly operated and maintained. This warranty shall extend for a period of one (1) year from the date of delivery to the original purchaser (or eighteen (18) months if the delivery to the original purchaser occurred outside the continental United States). This warranty is extended only to the original purchaser ("Purchaser"). *Purchaser's sole and exclusive remedy is the repair and/or replacement of nonconforming goods as provided in the following paragraphs.*

In the event Purchaser believes the goods are defective, the goods must be returned to HFC, transportation prepaid by Purchaser, within twelve (12) months after delivery of goods (or eighteen (18) months for goods delivered outside the continental United States) for inspection by HFC. If HFC's inspection determines that the workmanship or materials are defective, the goods will be either repaired or replaced, at HFC's sole determination, free of additional charge, and the goods will be returned, transportation paid by HFC, using the lowest cost transportation available.

Prior to returning the goods to HFC, Purchaser must obtain a Returned Material Authorization (RMA) Number from HFC's Customer Service Department within 30 days after discovery of a purported breach of warranty, but no later than the warranty period; otherwise, such claims shall be deemed waived. See the Return Requests/Inquiries Section of this manual.

If HFC's inspection reveals the goods are free of defects in material and workmanship or such inspection reveals the goods were improperly used, improperly installed, and/or improperly selected for service intended, HFC will notify the purchaser in writing and will deliver the goods back to Purchaser upon (i) receipt of Purchaser's written instructions and (ii) the cost of transportation. If Purchaser does not respond within thirty (30) days after notice from HFC, the goods will be disposed of in HFC's discretion.

HFC does not warrant these goods to meet the requirements of any safety code of any state, municipality, or other jurisdiction, and Purchaser assumes all risk and liability whatsoever resulting from the use thereof, whether used singly or in combination with other machines or apparatus.

This warranty shall not apply to any HFC goods or parts thereof, which have been repaired outside HFC's factory or altered in any way, or have been subject to misuse, negligence, or accident, or have not been operated in accordance with HFC's printed instructions or have been operated under conditions more severe than, or otherwise exceeding, those set forth in the specifications for such goods.

THIS WARRANTY IS EXPRESSLY IN LIEU OF ALL OTHER WARRANTIES, EXPRESSED OR IMPLIED, INCLUDING ANY IMPLIED WARRANTY OF MERCHANTABILITY OR FITNESS FOR A PARTICULAR PURPOSE.

HFC SHALL NOT BE LIABLE FOR ANY LOSS OR DAMAGE RESULTING, DIRECTLY OR INDIRECTLY, FROM THE USE OR LOSS OF USE OF THE GOODS. WITHOUT LIMITING THE GENERALITY OF THE FOREGOING, THIS EXCLUSION FROM LIABILITY EMBRACES THE PURCHASER'S EXPENSES FOR DOWNTIME OR FOR MAKING UP DOWNTIME, DAMAGES FOR WHICH THE PURCHASER MAY BE LIABLE TO OTHER PERSONS, DAMAGES TO PROPERTY, AND INJURY TO OR DEATH OF ANY PERSONS. HFC NEITHER ASSUMES NOR AUTHORIZES ANY PERSON TO ASSUME FOR IT ANY OTHER LIABILITY IN CONNECTION WITH THE SALE OR USE OF HFC'S GOODS, AND THERE ARE NO ORAL AGREEMENTS OR WARRANTIES COLLATERAL TO OR AFFECTING THE AGREEMENT. *PURCHASER'S SOLE AND EXCLUSIVE REMEDY IS THE REPAIR AND/OR REPLACEMENT OF NONCONFORMING GOODS AS PROVIDED IN THE PRECEDING PARAGRAPHS. HFC SHALL NOT BE LIABLE FOR ANY OTHER DAMAGES WHATSOEVER INCLUDING INDIRECT, INCIDENTAL, OR CONSEQUENTIAL DAMAGES.*

CONTENTS

1. Outline	1
1-1 Features	1
1-2 Specifications	2
1-3 Model Number	3
2. Operation	5
2-1 Opening/Closing of Printer	5
2-2 Installing Paper.....	5
2-3 Printing.....	5
3. Diagnostics and Set-Up	7
3-1 Self-Test	7
3-2 Set-up Mode	7
3-3 Dump Mode	8

Drawing:

ACE-P8 Internal Wiring With Optional Heater	11
---	----

Additional Drawings

1. OUTLINE

The Hoffer ACE P8 is a line thermal paper printer for use with ACE II and ACE-B cryogenic flow computers. It is a compact lightweight printer with RS232 interface, can be used in a variety of commercial and industrial applications in which small size without compromising performance and reliability.

1-1 FEATURES

1. Point of sale printed delivery ticket.
2. Customize delivery tickets (contact factory).
3. Reproduction of lost or damaged delivery ticket prior to the start of next delivery.
4. Maintenance reports for calibration and malfunction history.
5. Preventive maintenance schedule and recalibration date printing on daily trip report.
6. Log failure report for maintenance personnel.
7. Self test to check control circuit function, printer mechanism and printing quality.
8. Shock mounted waterproof NEMA 4X enclosure.
9. Optional heaters for operation below 32 deg F.

1-2 SPECIFICATIONS

Printer Characteristics:

Printing Method	Line Thermal Printing
No. of columns	42, 24
Dot Density	8 dots/mm (203 dpi)
Print Speed	2 inches/sec
Print Width	48.8mm, 384 dots
Characters per Line	Font A: 32 characters/line Font B: 42 characters/line
Recommended Paper	58mm +/- x 2.25 inch diameter Roll thermal paper (TP58)
Interfaces	IRS-232C
Power	12, 24 VDC
Dimension	7.7"x7.7"x7.0"
Environmental (without heaters)	
Temperature	0° to 50° C (ambient)
Relative Humidity	35% to 85%, non-condensing
Reliability	MCBF 50 million pulses Print head 50 km of paper

1-3 MODEL NUMBER

Model ACE- P8- () - () - () - ()

Power Options

- (12) 12 VDC Power Input.
- (24) 24 VDC Power Input.
- (115/220) 115/220 A/C Voltage Input (includes A/C power cable).

Heaters

- (H) Heater –Required when temperature falls below 32 Deg.F.

Enclosures

- (M) The printer is mounted in a fiberglass water-proof enclosure that meets Nema 4X and is supplied complete with shock mounts. The enclosure needs to mount in a semi-protected area from melting frosted pipes.

Special Features

- (SP) Any special features that are not covered in the model number use a written description of the –SP.

This page intentionally left blank.

2. OPERATION

2-1 Opening/Closing of Printer Cover.

- To open, position your fingers on both sides of the printer as shown in the picture and push the cover up.
- To close, make sure the paper is straight and press on the cover.



2-2 Installing Paper

Please ensure that correct paper is used with the ACE P8 (Media: TP58-98; Width: 58mm; Diameter: 2.25”).

- Open the cover and remove the old paper core.
- Drop the new paper roll into the paper compartment with the emulsion side down, against the printer head.
- Hold the front edge of the paper outside the printer and close the cover.



2-3 Printing

- Make sure printer is on line.
- Press FEED button. If paper advances printer is off-line.
- Press ONLINE button to put printer on line.

Note: There is no visual online indicator. Printer switches between online and offline mode when the ONLINE button is pressed.

This page intentionally left blank.

3. DIAGNOSTICS AND SET UP

3-1 Self-Test

The self-test checks the following:

- Control circuit functions
- Control ROM version
- Program setting
- Printer quality

Running the self-test:

- Make sure the paper is installed correctly and paper cover is closed.
- Turn on the power, while pressing FEED button.
- Setup is printed, followed by a string of test characters (about 92 lines).

3-2 Set-up mode

Follow these steps to change printer settings:

- Turn on the power while pressing the ONLINE button, the printer will go into set-up mode and print the current parameter status.
- The power LED indicator will flash every second to indicate setup mode.
- Each time the ONLINE button is pressed and released the next printer parameter is printed. Pressing the FEED button will cause the status of that parameter to change.
- Once the corrected status has been selected, press ONLINE button while pressing the FEED button.

Note: If no buttons are pressed for 15 seconds, the set-up mode is automatically terminated without changing the original parameters.

Factory Default Settings:

Baud Rate: 9600	Parity: None
Handshaking: XON/XOFF	Print Mode: Text (upright)
Country: U.S.A	Paper: Normal paper
	Density: 100%

3-3 Dump mode

The purpose of dump mode is to check whether the printer is receiving the data correctly from host.

Running the dump mode:

- Turn off power
- Turn on the power while pressing SEL and FEED buttons simultaneously

DRAWING

This page intentionally left blank.

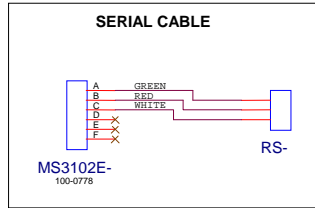

	12V	24V
* H1,	25 OHM 100-	100 OHM 100-
THERMOSTA	100-	100-

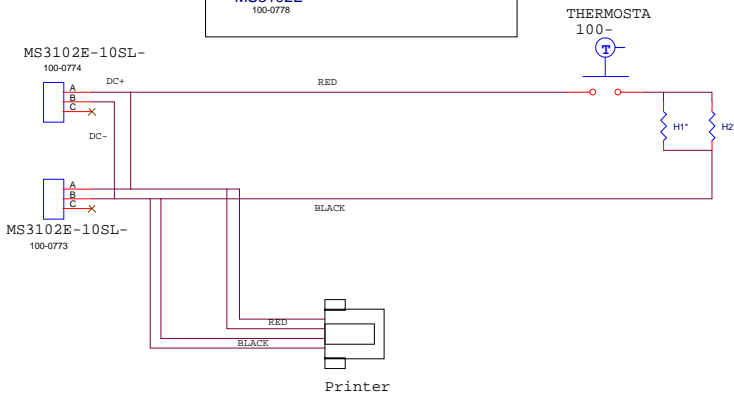

ACE-P8 Internal Wiring With Optional Heater

This page intentionally left blank.

ADDITIONAL DRAWINGS

This page intentionally left blank.

REVISIONS			
REV	DESCRIPTION	DATE	APP
A	PER ECP 540	080211	V.K.
B	REVISED PER REDLINED DRAWING	090225	

- NOTES:
- SPECIFY CABLE LENGTH WHEN ORDERING.
 - USE CAROL P/N C2687 CABLE (STOCK# 100-1936) OR EQUIVALENT.
 - BOND SHIELD TO CONNECTOR CABLE CLAMP.

SCA-XCU3-P
 X DESIGNATES LENGTH
 NOTE 1

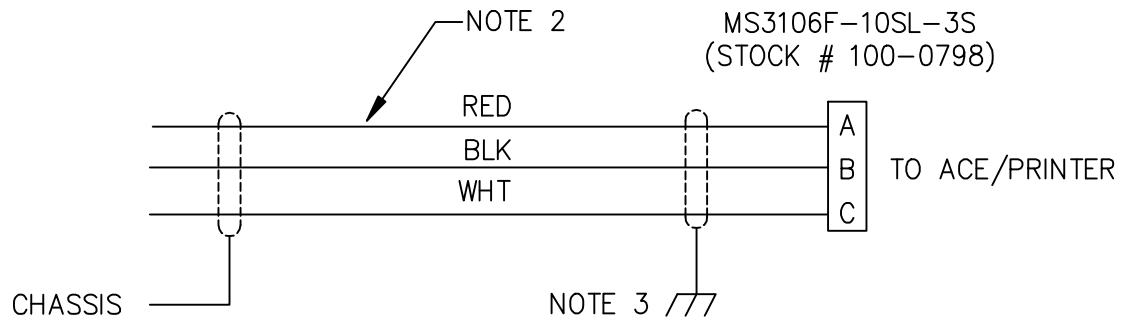

		MATERIAL	DRAWN SWEET	DATE	 HOFFER FLOW CONTROLS, INC. ELIZABETH CITY, NC 27909			
		NOTE 2	CHECK V.KEPKA	030527				
		FINISH	PROJ ENG V.KEPKA	030527				
		CONFIDENTIAL PROPERTY OF HOFFER FLOW CONTROLS, INC. (HFC) NOT TO BE DISCLOSED TO OTHERS, REPRODUCED, OR USED FOR ANY OTHER PURPOSE, EXCEPT AS AUTHORIZED IN WRITING BY HFC. MUST BE RETURNED ON DEMAND, ON COMPLETION OF ORDER OR OTHER PURPOSE FOR WHICH LENT.			TITLE CABLE, POWER-ACE/PRINTER			
NEXT ASSY	USED ON	UNLESS OTHERWISE SPECIFIED DIMENSIONS ARE IN INCHES TOLERANCES OTHER THAN RAW MATERIAL SHALL BE HELD AS FOLLOWS: 2 PLACE DECIMAL ±.01 3 PLACE DECIMAL ±.005 FRACTIONAL ±1/64 ANGULAR ±1/2°			SIZE A 33321	FSCM NO SCA-912	DWG NO B	REV B
APPLICATION					SCALE NONE	SHEET 1 OF 1		

NOTES:

1. SPECIFY CABLE LENGTH WHEN ORDERING.
2. USE MANHATTEN P/N M5423 CABLE OR EQUAL.
3. BOND SHIELD TO CONNECTOR CABLE CLAMP.

CABLE PART NUMBER:

SCA-XCC3-P

X DESIGNATES LENGTH
(NOTE 1)

REVISIONS

REV	DESCRIPTION	DATE	APP
A	ADDED NOTE 3 AND SHIELD. (CS)	941213	JD
B	NOTE 3 P/N WAS M33573. (CS)	950102	JD
C	PER ECP 540, DWG NO WAS 100-2026	080211	V.K.
D	PER ECP 561, REMOVED SHIELD FROM PRINTER END OF CABLE	091120	JJ

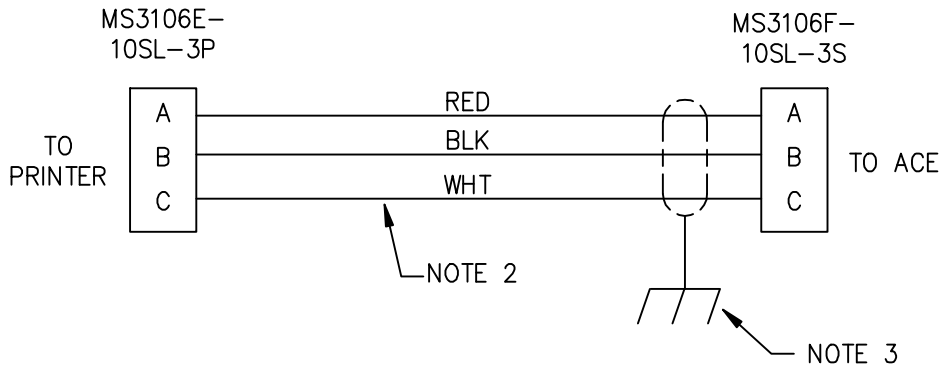

REPLACES 100-2026

		MATERIAL	CONTRACT/JN		 HOFFER FLOW CONTROLS, INC. ELIZABETH CITY, NC 27909
		NOTE 2	DRAWN SWEET	DATE 940803	
		FINISH	CHECK J.DEFEO	940803	
			QA		
			PROJ ENG		TITLE POWER CABLE, PRINTER TO ACE- OMIL
		CONFIDENTIAL PROPERTY OF HOFFER FLOW CONTROLS, INC. (HFC) NOT TO BE DISCLOSED TO OTHERS, REPRODUCED, OR USED FOR ANY OTHER PURPOSE, EXCEPT AS AUTHORIZED IN WRITING BY HFC. MUST BE RETURNED ON DEMAND, ON COMPLETION OF ORDER OR OTHER PURPOSE FOR WHICH LENT.	UNLESS OTHERWISE SPECIFIED DIMENSIONS ARE IN INCHES TOLERANCES OTHER THAN RAW MATERIAL SHALL BE HELD AS FOLLOWS: 2 PLACE DECIMAL ±.01 3 PLACE DECIMAL ±.005 FRACTIONAL ±1/64 ANGULAR ±1/2°		SIZE CAGE CODE DWG NO REV A 33321 SCA-915 D
NEXT ASSY	USED ON		APPLICATION		SCALE NONE



REVISIONS

REV	DESCRIPTION	DATE	APP
A	DRAWING NO. WAS ACE-923. (CS)	951002	JD
B	PER ECP 540, DWG NO WAS 700-0068	080211	V.K.
C	PER ECP 561, REMOVED SHIELD FROM PRINTER END OF CABLE	091120	JJ

NOTES:

- SPECIFY CABLE LENGTH WHEN ORDERING.
- USE WIRE TYPE CAROL P/N C078-21-10 OR EQUIVALENT.
- BOND SHIELD TO CONNECTOR CABLE CLAMP.

SCA-X-CC4-RS232

X DESIGNATES LENGTH
NOTE 1

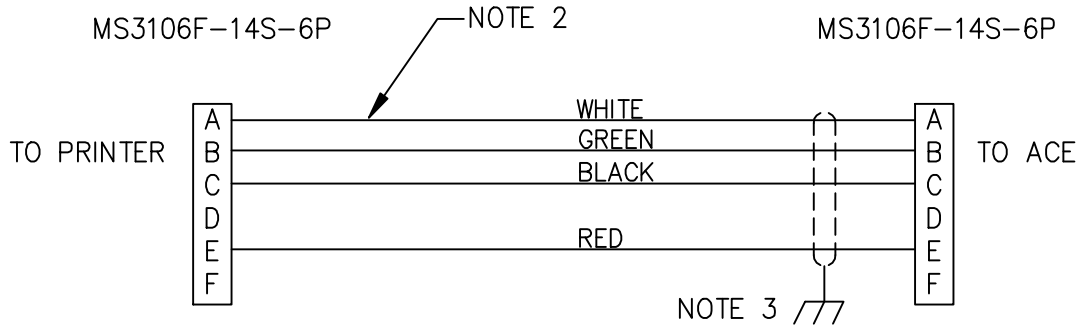

		MATERIAL	CONTRACT/JN		H HOFFER FLOW CONTROLS, INC. ELIZABETH CITY, NC 27909	
		NOTE 2	DRAWN SWEET	DATE 920914		
		FINISH	CHECK JAS	920914		
			QA H.COVELL	920915	TITLE CABLE, ACE/PRINTER SYSTEM	
			PROJ ENG KRH	920915		
		CONFIDENTIAL PROPERTY OF HOFFER FLOW CONTROLS, INC. (HFC) NOT TO BE DISCLOSED TO OTHERS, REPRODUCED, OR USED FOR ANY OTHER PURPOSE, EXCEPT AS AUTHORIZED IN WRITING BY HFC. MUST BE RETURNED ON DEMAND, ON COMPLETION OF ORDER OR OTHER PURPOSE FOR WHICH LENT.	UNLESS OTHERWISE SPECIFIED DIMENSIONS ARE IN INCHES TOLERANCES OTHER THAN RAW MATERIAL SHALL BE HELD AS FOLLOWS: 2 PLACE DECIMAL ±.01 3 PLACE DECIMAL ±.005 FRACTIONAL ±1/64 ANGULAR ±1/2°			
NEXT ASSY	USED ON		SIZE A	FSCM NO 33321	DWG NO SCA-918	REV C
APPLICATION			SCALE NONE	SHEET 1 OF 1		





REVISIONS

REV	DESCRIPTION	DATE	APP
A	CHANGED SHIELD FORM - TO CHASSIS. (CS)	920925	JAS
B	DRAWING NO. WAS ACE-921. (CS)	951002	JD
C	PER ECP 540, DWG NO WAS 700-0066	080212	V.K.
D	REVISED PER REDLINED DRAWING	090225	

NOTES:

1. SPECIFY CABLE LENGTH WHEN ORDERING.
2. USE ALPHA P/N 5362 CABLE OR EQUIVALENT.
3. BOND SHIELD TO CONNECTOR CABLE CLAMP.

SCA-XCU2-P

X DESIGNATES LENGTH
NOTE 1

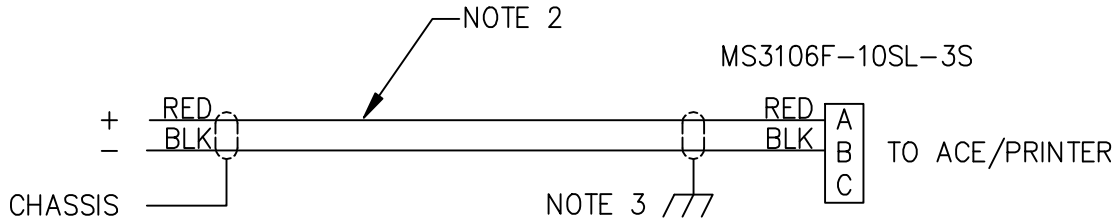

REPLACES 700-0066

		MATERIAL	CONTRACT/JN		 HOFFER FLOW CONTROLS, INC. ELIZABETH CITY, NC 27909
		NOTE 2	DRAWN SWEET	DATE 920914	
		FINISH	CHECK JAS	920914	
			QA H.COVELL	920914	
			PROJ ENG K.HOFFER	920915	TITLE
			UNLESS OTHERWISE SPECIFIED DIMENSIONS ARE IN INCHES TOLERANCES OTHER THAN RAW MATERIAL SHALL BE HELD AS FOLLOWS:		CABLE, POWER-ACE/PRINTER
			2 PLACE DECIMAL ±.01	3 PLACE DECIMAL ±.005	
		CONFIDENTIAL PROPERTY OF HOFFER FLOW CONTROLS, INC. (HFC) NOT TO BE DISCLOSED TO OTHERS, REPRODUCED, OR USED FOR ANY OTHER PURPOSE, EXCEPT AS AUTHORIZED IN WRITING BY HFC. MUST BE RETURNED ON DEMAND, ON COMPLETION OF ORDER OR OTHER PURPOSE FOR WHICH LENT.			SIZE A FSCM NO 33321 DWG NO SCA-920 REV D
NEXT ASSY	USED ON				SCALE NONE
APPLICATION					SHEET 1 OF 1

