

*DC or AC Powered Microprocessor
Controlled Transmitter*

Model: CAT3

USER'S MANUAL



HP-312

April 2009

H **HOFFER FLOW CONTROLS, INC.**
The Turbine Flowmeter Company

107 Kitty Hawk Lane, P.O. Box 2145, Elizabeth City, NC 27906-2145
800-628-4584 252-331-1997 FAX 252-331-2886
www.hofferflow.com E-mail: info@hofferflow.com

Notice

HOFFER FLOW CONTROLS, INC. MAKES NO WARRANTY OF ANY KIND WITH REGARD TO THIS MATERIAL, INCLUDING, BUT NOT LIMITED TO, THE IMPLIED WARRANTIES OF MERCHANTABILITY AND FITNESS FOR A PARTICULAR PURPOSE.

This manual has been provided as an aid in installing, connecting, calibrating, operating, and servicing this unit. Every precaution for accuracy has been taken in the preparation of this manual; however, HOFFER FLOW CONTROLS, INC. neither assumes responsibility for any omissions or errors that may appear nor assumes liability for any damages that may result from the use of products in accordance with information contained in the manual.

HOFFER FLOW CONTROLS' policy is to provide a user manual for each item supplied. Therefore, all applicable user manuals should be examined before attempting to install or otherwise connect a number of related subsystems.

During installation, care must be taken to select the correct interconnecting wiring drawing. The choice of an incorrect connection drawing may result in damage to the system and/or one of the components.

Please review the complete model of each item to be connected and locate the appropriate manual(s) and/or drawing(s). Identify all model numbers exactly before making any connections. A number of options and accessories may be added to the main instrument, which are not shown on the basic user wiring. Consult the appropriate option or accessory user manual before connecting it to the system. In many cases, a system wiring drawing is available and may be requested from HOFFER FLOW CONTROLS.

This document contains proprietary information, which is protected by copyright. All rights are reserved. No part of this document may be photocopied, reproduced, or translated to another language without the prior consent of HOFFER FLOW CONTROLS, INC.

HOFFER FLOW CONTROLS' policy is to make running changes, not model changes, whenever an improvement is possible. This affords our customers the latest in technology and engineering. The information contained in this document is subject to change without notice.

RETURN REQUESTS/INQUIRIES

Direct all warranty and repair requests/inquiries to the Hoffer Flow Controls Customer Service Department, telephone number (252) 331-1997 or 1-800-628-4584. BEFORE RETURNING ANY PRODUCT(S) TO HOFFER FLOW CONTROLS, PURCHASER MUST OBTAIN A RETURNED MATERIAL AUTHORIZATION (RMA) NUMBER FROM HOFFER FLOW CONTROLS' CUSTOMER SERVICE DEPARTMENT (IN ORDER TO AVOID PROCESSING DELAYS). The assigned RMA number should then be marked on the outside of the return package and on any correspondence.

FOR **WARRANTY** RETURNS, please have the following information available BEFORE contacting HOFFER FLOW CONTROLS:

1. P.O. number under which the product was PURCHASED,
2. Model and serial number of the product under warranty, and
3. Repair instructions and/or specific problems relative to the product.

FOR **NON-WARRANTY** REPAIRS OR **CALIBRATIONS**, consult HOFFER FLOW CONTROLS for current repair/calibration charges. Have the following information available BEFORE contacting HOFFER FLOW CONTROLS:

1. P.O. number to cover the COST of the repair/calibration,
2. Model and serial number of the product, and
3. Repair instructions and/or specific problems relative to the product.

LIMITED WARRANTY

HOFFER FLOW CONTROLS, INC. ("HFC") warrants HFC's products ("goods") described in the specifications incorporated in this manual to be free from defects in material and workmanship under normal use and service, but only if such goods have been properly selected for the service intended, properly installed and properly operated and maintained. This warranty shall extend for a period of (1) year from the date of delivery to the original purchaser (or eighteen (18) months if the delivery to the original purchaser occurred outside the continental United States). This warranty is extended only to the original purchaser ("Purchaser"). *Purchaser's sole and exclusive remedy is the repair and/or replacement of nonconforming goods as provided in the following paragraphs.*

In the event Purchaser believes the goods are defective, the goods must be returned to HFC, transportation prepaid by Purchaser, within twelve (12) months after delivery of goods (or eighteen (18) months for goods delivered outside the continental United States) for inspection by HFC. If HFC's inspection determines that the workmanship or materials are defective, the goods will be either repaired or replaced, at HFC's sole determination, free of additional charge, and the goods will be returned, transportation paid by HFC, using the lowest cost transportation available.

Prior to returning the goods to HFC, Purchaser must obtain a Returned Material Authorization (RMA) Number from HFC's Customer Service Department within 30 days after discovery of a purported breach of warranty, but no later than the warranty period; otherwise, such claims shall be deemed waived. See the Return Requests/Inquiries Section of this manual.

If HFC's inspection reveals the goods are free of defects in material and workmanship or such inspection reveals the goods were improperly used, improperly installed, and/or improperly selected for service intended, HFC will notify the purchaser in writing and will deliver the goods back to purchaser upon (i) receipt of Purchaser's written instructions and (ii) the cost of transportation. If Purchaser does not respond within 30 days after notice from HFC, the goods will be disposed of in HFC's discretion.

HFC does not warrant these goods to meet the requirements of any safety code of any state, municipality, or any other jurisdiction, and purchaser assumes all risk and liability whatsoever resulting from the use thereof, whether used singly or in combination with other machines or apparatus.

This warranty shall not apply to any HFC goods or parts thereof, which have been repaired outside HFC's factory or altered in any way, or have been subject to misuse, negligence, or accident, or have not been operated in accordance with HFC's printed instructions or have been operated under conditions more severe than, or otherwise exceeding, those set forth in the specifications for such goods.

THIS WARRANTY IS EXPRESSLY IN LIEU OF ALL OTHER WARRANTIES, EXPRESSED OR IMPLIED, INCLUDING ANY IMPLIED WARRANTY OF MERCHANTABILITY OR FITNESS FOR A PARTICULAR PURPOSE. HFC SHALL NOT BE LIABLE FOR ANY LOSS OR DAMAGE RESULTING, DIRECTLY OR INDIRECTLY, FROM THE USE OF LOSS OF USE OF THE GOODS. WITHOUT LIMITING THE GENERALITY OF THE FOREGOING, THIS EXCLUSION FROM LIABILITY EMBRACES THE PURCHASER'S EXPENSES FOR DOWNTIME, DAMAGES FOR WHICH THE PURCHASER MAY BE LIABLE TO OTHER PERSONS, DAMAGES TO PROPERTY, AND INJURY TO OR DEATH OF ANY PERSON. HFC NEITHER ASSUMES NOR AUTHORIZES ANY PERSON TO ASSUME FOR IT ANY OTHER LIABILITY IN CONNECTION WITH THE SALE OR USE OF HFC'S GOODS, AND THERE ARE NO AGREEMENTS OR WARRANTIES COLLATERAL TO OR AFFECTING THE AGREEMENT. PURCHASER'S SOLE AND EXCLUSIVE REMEDY IS THE REPAIR AND/OR REPLACEMENT OF NONCONFORMING GOODS AS PROVIDED IN THE PRECEDING PARAGRAPHS. HFC SHALL NOT BE LIABLE FOR ANY OTHER DAMAGES WHATSOEVER INCLUDING INDIRECT, INCIDENTAL, OR CONSEQUENTIAL DAMAGES.

Disclaimer:

Specifications are subject to change without notice.
Some pages are left intentionally blank.

CONTENTS

1. Introduction	1
1.1. Model Number Designation	3
2. Specifications	7
3. Installation and Operation	9
3.1. Power Supply.....	9
3.2. Flowmeter Input.....	10
3.3. Pulse Output	12
3.4. Analog Output.....	14
3.5. Alarm Outputs.....	16
3.5. Communications Connections.....	18
3.6. Wiring	18
Appendix A – Default Configuration	19
Appendix B - Communications	21
Message Format And Timeout	21
Messages	23

1. Introduction

The CAT3 is a versatile DC or AC powered microprocessor-based transmitter, which provides pulse output, analog output and High/Low flow alarm options. Up to 3 circuit boards may be installed to provide a variety of input/output options.

The flowmeter input circuitry will accept a variety of signal types including, low level sinusoidal, MCP/RF, pulse and contact closure. Optional 20-point linearization is available to correct for flowmeter non-linearities, improving overall system accuracy. The CAT3 is compatible with all Hoffer turbine flowmeters as well as the H.O.G. series positive displacement flowmeters.

CAT3 Block Diagram

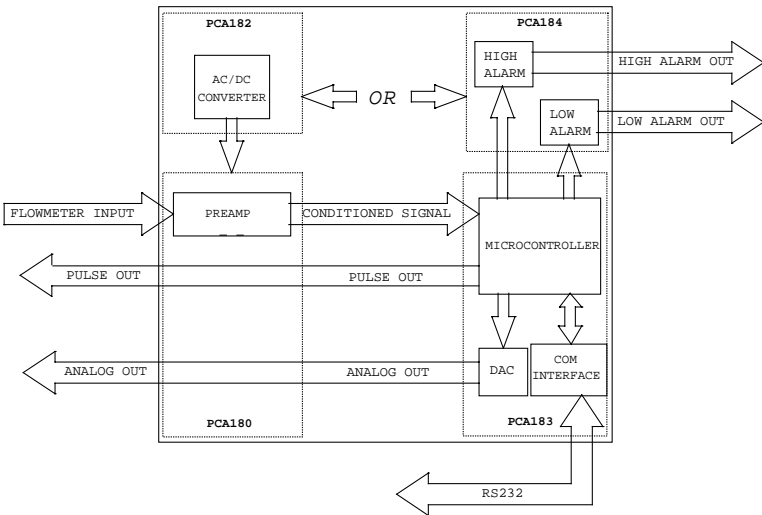

An RS232 communications port located under the top plate allows CAT3 to be remotely configured using a Windows based application that included with all units. Configuration and remote monitoring may also be performed using any PC based communications program (e.g., HyperTerminal) or ASCII terminal.

2 Introduction

The standard unit is packaged in an extruded aluminum enclosure for wall mounting or may be mounted directly on a flowmeter using an optional NEMA 4X or EX enclosure. An optional bracket is also available for mounting on standard DIN rail.

This instrument is designed to conform to the EMC-Directive of the Council of European Communities 89/336/EEC and the following standards:

Generic Emission Standard EN 50081-1

Residential, Commercial & Light Industry Environment.

Generic Emission Standard EN 50081-2

Industrial Environment.

Generic Immunity Standard EN 50082-1

Residential, Commercial & Light Industry Environment.

Generic Immunity Standard EN 50082-2

Industrial Environment.

1.1. Model Number Designation

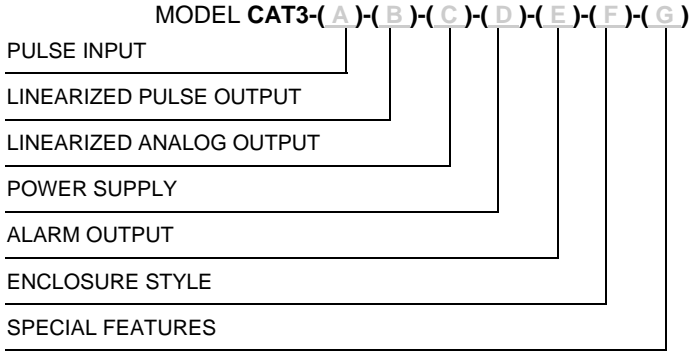

PULSE INPUT

MODEL CAT3-(A)-()-()-()-()-()-()

OPTION (A)

- (1) MAG COIL, PULSE, DRY CONTACT
- (2) MC3P
- (3) ISOLATED PULSE, RPM, RPR AND HALL EFFECT COILS

LINEARIZED PULSE OUTPUT

MODEL CAT3-()-(B)-()-()-()-()-()

OPTION (B)

- (1) 0-5 TTL / CMOS
- (2) OPEN COLLECTOR
- (3) OPEN COLLECTOR WITH PULL UP TO V+
- (4) AC SQUARE WAVE
- (5) 0-10V SQUARE WAVE
(REQUIRES CUSTOMER SUPPLIED POWER, 12-30 VDC)

LINEARIZED ANALOG OUTPUT

MODEL CAT3-()-()-(C)-()-()-()-()

OPTION (C)

- (1) 4-20 MA
- (5) 1-5 VDC

POWER SUPPLY

MODEL CAT3-()-()-()-(D)-()-()-()

OPTION (D)

- (DC) 8-30 VDC
- (AC)* 100-240 VAC

- *NOTES:
1. WHEN (AC) IS SELECTED, THE ALARM OPTION IS NOT AVAILABLE. USE REMOTE ACC39B POWER SUPPLY IF REQUIRED.
 2. DOME OPTION OF THE ENCLOSURE MUST BE USED WITH (AC) POWER.
 3. WHEN (AC) IS SELECTED, ACC39B POWER SUPPLY MUST BE USED WHEN COMBINING ANY ANALOG OUTPUT WITH MC3P PULSE INPUT (2) OR RPM/RPR PULSE INPUT (3).

4 Introduction

ALARM OUTPUT

MODEL CAT3-()-()-()-()-(E)-()-()

OPTION (E)

- (4) HIGH OPEN COLLECTOR
- (5) HIGH TTL / CMOS
- (6) HIGH RELAY ONE SPDT, CONTACT RATED @ 2A 30V
- (7) LOW OPEN COLLECTOR
- (8) LOW TTL / CMOS
- (9) LOW RELAY ONE SPDT, CONTACT RATED @ 2A 30V

NOTE: WHEN ALARM OPTION IS SELECTED, (AC) POWER IS NOT AVAILABLE. USE REMOTE ACC39B POWER SUPPLY.

ENCLOSURE STYLE

MODEL CAT3-()-()-()-()-(F)-()-()

OPTIONS (F)

- (1) GENERAL PURPOSE.
2.6"L X 2.6"H X 2.6"W MINIMUM MOUNTING SPACE.

- (D) 2" LONG DIN RAIL MOUNT SINGLE UNIT.
UP TO 20 CAT3 UNITS CAN BE MOUNTED ON A SINGLE RAIL. ADD 2" PER UNIT.

- (3/O)* MEETS CLASS 1, DIV. 1 AND 2, GROUPS C**, D
(3H/O)** CLASS II, GROUPS E, F, G
NEMA 4X WITH 'O' RING
CERTIFIED CSA, UL

BODY KILARK #GECCT-3, STOCK #200-0945
* USE FLAT COVER FOR OPTION (3/O), STOCK #200-0533,
KILARK #GECBC.
** DOME COVER DOES NOT MEET GROUP C.
*** USE DOME COVER FOR MODEL (3H/O), STOCK #200-0398,
KILARK #2GOU.
*** DOME COVER MUST BE USED FOR A/C POWERED UNITS.

- (3B/O)* MEETS CLASS I, DIV. 1 AND 2, GROUPS A, B, C, D
(3BH/O)** CLASS 1, ZONES 1 AND 2, GROUPS IIB + H2, IIA
CLASS II, DIV. 1 AND 2, GROUPS E, F, G
CLASS III
NEMA 3, 4, 7 (B, C, D), 9 (E, F, G)
CERTIFIED CENELEC, CSA, UL, FM
BODY KILARK #HKB, STOCK #200-0406
* USE FLAT COVER FOR OPTION (3B/O), STOCK #200-0773,
KILARK #HKB-B.
** USE DOME COVER FOR MODEL (3BH/O).

- (3B/O-ATEX) EExd II C ENCLOSURE. ATEX-APPROVED ¾" FNPT CABLE FEATURES.

NOTE: WHEN USING THE AC OPTION WITH A 3/O, 3B/O, OR 3B/O-ATEX ENCLOSURE, THE HIGH DOME IS REQUIRED BECAUSE THE AC CONNECTOR IS SLIGHTLY TALLER THAN THE REST.

SPECIAL FEATURES

MODEL CAT3-()-()-()-()-()-()-(G)

OPTIONS (G)

(CE) MARK REQUIRED FOR EUROPE

(SP) ANY SPECIAL FEATURES THAT ARE NOT COVERED IN THE MODEL NUMBER, USE A WRITTEN DESCRIPTION OF THE -SP.

- NOTES:
1. PULSE SCALING IS SUPPLIED AS A STANDARD IN THE BASE PRIZE AND IS SCALED TO THE UNIT MEASURE.
 2. WINDOWS® BASED SETUP DISC AND 6 FOOT COMMUNICATION CABLE AVAILABLE.

6 Introduction

This page intentionally left blank.

3. Specifications

General Specifications

Input Signal Type: Magnetic pick up, MCP pick up, Contact Closure, Pulse

Input frequency range: 0.2 Hz to 4 KHz

Signal level: 10 mV rms to 30 Vdc

Power supply: 8-30 Vdc (Reverse polarity protected)
100-240 Vac (Fuse rating 0.5A, 250 Vac)

Analog Output: 4-20mA, 1-5V
24mA overflow condition

Load resistance: Max 650 Ohms at 24 Vdc

Accuracy: +/- 0.02% of full scale @ 20° C

Temperature drift: 40ppm/deg C

Pulse output 0-5, 0-10V*, Open Collector, AC square
*Requires 12-30 Vdc Power Supply
Internal pull-up resistor 10k Ohms
Recommended load min. 50k Ohms

Pulse Scaling Per flow unit of measure, divide by 1, 10, 100

Hi/Lo Alarm Relay (2A, 30 Vdc), 0-5V, Open Collector
(0.5A, 30 Vdc)

Communications RS232 port for Configuration and diagnostics

Operating temperature: -40 to 85 C°

Humidity: 0-90% Non-condensing

Enclosure: Extruded aluminum
DIN rail mount
Explosion Proof

Regulatory: CE compliant

Options

20 point linearization

8 Specifications

This page intentionally left blank.

4. Installation and Operation

4.1. Power Supply

DC Power (8-30 VDC)

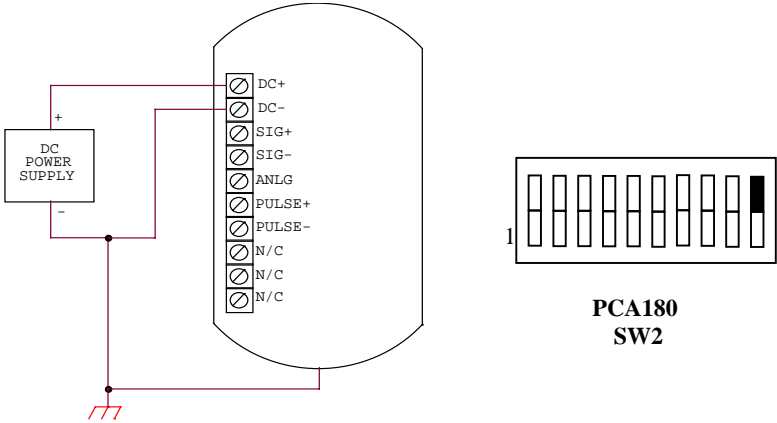

AC Power (100-240 VAC)

AC power for CAT3 requires an optional circuit board, PCA182. The Alarm option (PCA184) is not available when the AC Power option is equipped.

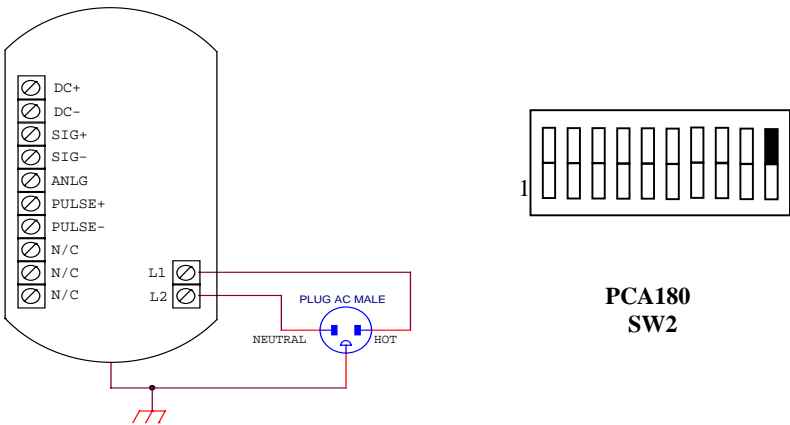

10 Installation and Operation

4.2. Flowmeter Input

The Preamp circuitry for conditioning the flow signal is located on PCA180. The following drawings illustrate typical connections and switch settings on PCA180 for various input signals.

Magnetic Pickup Coil

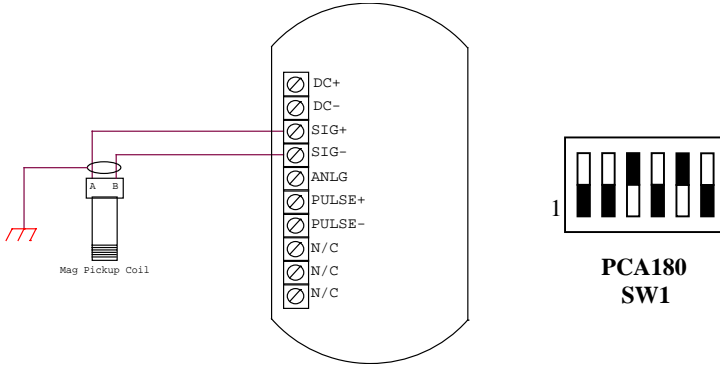

MCP/RF Coil

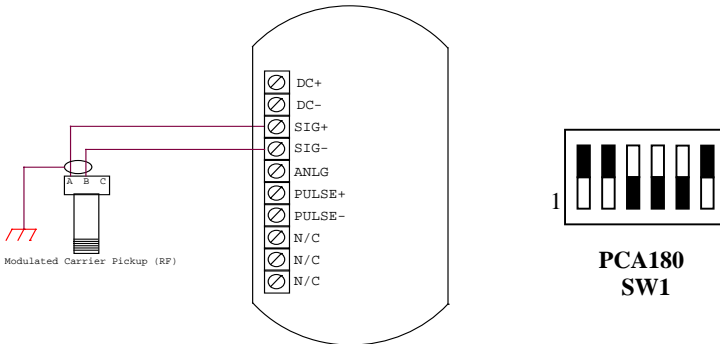

Redi-Pulse (TTL Pulse)

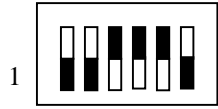
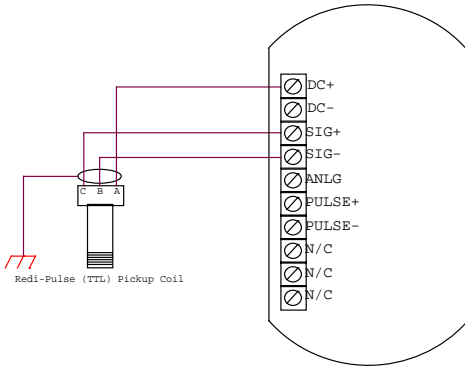

**PCA180
SW1**

Redi-Pulse (Open Collector)

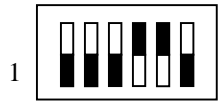
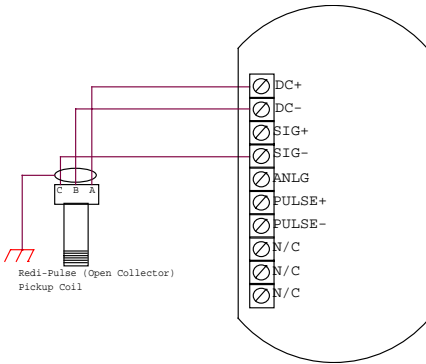

**PCA180
SW1**

12 Installation and Operation

4.3. Pulse Output

CAT3 provides a Pulse Output option that is scaled per flow unit of measure by a factor of 1, 10 or 100. The following drawings illustrate typical connections and switch settings for various pulse output options.

TTL(0-5V), 0-10V, High Level (DC In), AC Square

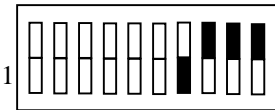
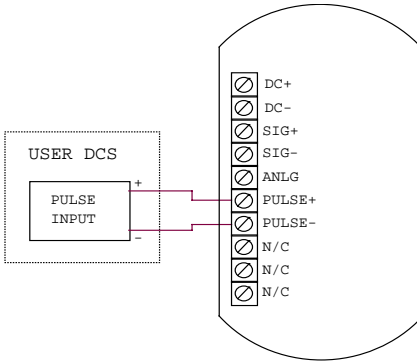

**PCA180
SW2**

TTL(0-5V), 0-10V, AC Square

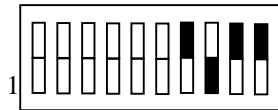

**PCA180
SW2**

High Level Pulse, AC Square

Open Collector, Isolated Pulse

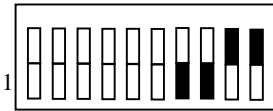
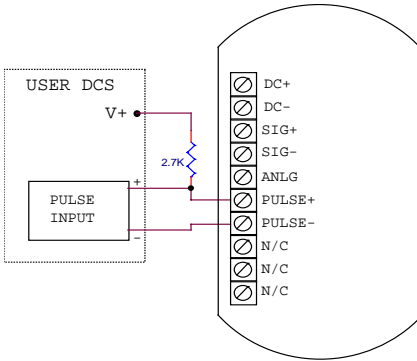

**PCA180
SW2**

Open Collector

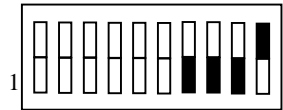

**PCA180
SW2**

Isolated Pulse

14 Installation and Operation

4.4. Analog Output

CAT3 provides an Analog Output option that will output an analog current or voltage that is proportional to the flow rate.

Analog Output

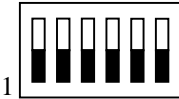
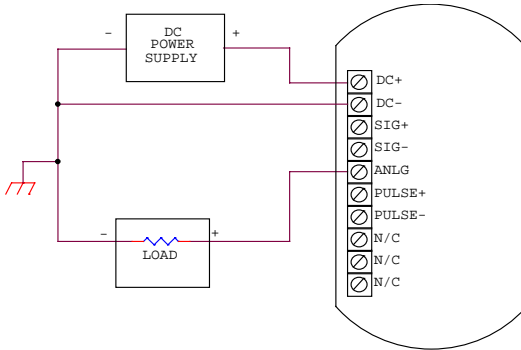

**PCA183
SW1**

4–20 mA Output

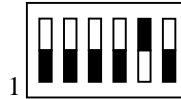

**PCA183
SW1**

1-5 V Output

The Microcontroller, located on PCA183, accepts the square-wave output of the preamplifier and performs all of the calculations that are required to control the Loop Driver. After measuring the frequency of the square-wave, the Microcontroller uses the following equations to compute the flow rate and current.

$$\text{flowrate} = \frac{\text{frequency}}{\text{Kfactor}} \times 60^{FM} \times CF$$

Where:

- Kfactor = Is dependent on the Flow Calculation Method setting and is either the Average K-Factor or the Linearized K-Factor from the Frequency / K-Factor table.
- FM = Is the Flow rate Units setting of 0, 1, or 2. Where “0” is for Seconds, “1” is for Minutes, and “2” is for Hours.
- CF = Is the Correction Factor setting.

$$current = 4mA + \left(16mA \times \frac{flowrate}{AF} \right)$$

Where:

- AF = Is the 20 mA maximum Flow rate value.

If the calculated flowrate is greater than the AF setting, the current will be set to 24mA to indicate an “Over-range” condition. After calculating the current, the Microcontroller digitally sends the current information to the Loop Driver. The loop driver, located on PCA183, uses the digital information sent to it by the Microcontroller to set the current of the loop. The Loop Driver also supplies power to the Microcontroller.

The analog output response time to reach steady state due to a change in the flow rate is approximately two (1/8) seconds. When flow stops, the time for the analog output to return to 4 mA will be between 3 and 12 seconds, depending on the Maximum Sample Time (MST) setting. MST is adjusted using the NB=(DATA) command, where NB is a value between 1 and 80. The default MST setting is NB= 1. Adjusting the MST is only recommended for low flow applications where the minimum input frequency is below 1 Hz.

16 Installation and Operation

3.5 Alarm Outputs

CAT3 provides an optional High/Low Flow Alarm feature. Alarms require an optional circuit board, PCA184. The Alarm option is not available when the AC Power option is equipped. The drawings below illustrate the typical connections and switch settings for various alarm options.

Hi/Lo Alarm Relay

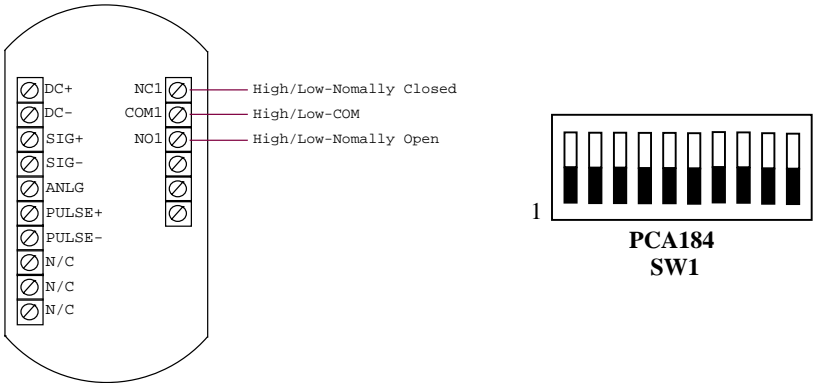

Hi/Lo Alarm TTL(0-5V)

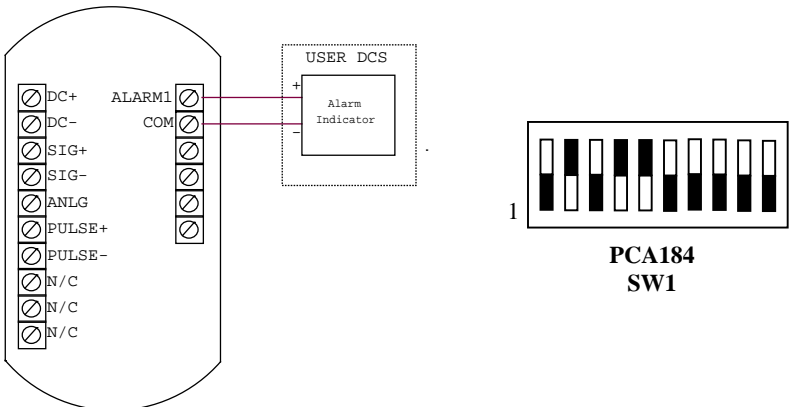

Hi/Lo Alarm Open Collector

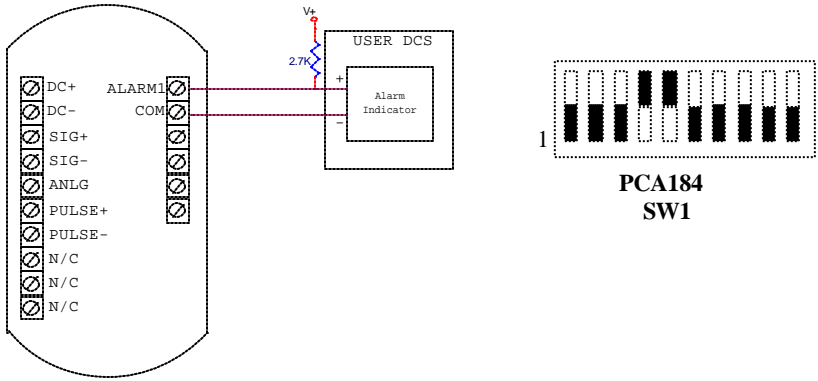

18 Installation and Operation

4.5. Communications Connections

The RS232 serial port connector is located under the top plate of CAT3 and may be accessed by removing the two screws from the top plate. A matching connector is provided with HOFFER HIT2A-301 Communications Cable. CAT3 unit has to be powered from external supply in order to be able to communicate. Additional power for CAT3 communication circuitry is supplied by the RS232 serial port of the computer/terminal. COM port settings must be set as follows:

Baud Rate: 2400
Data Bits: 8
Parity: None
Stop bits: 1
Handshaking: None

HOFFER HIT2A-301 Communications Cable

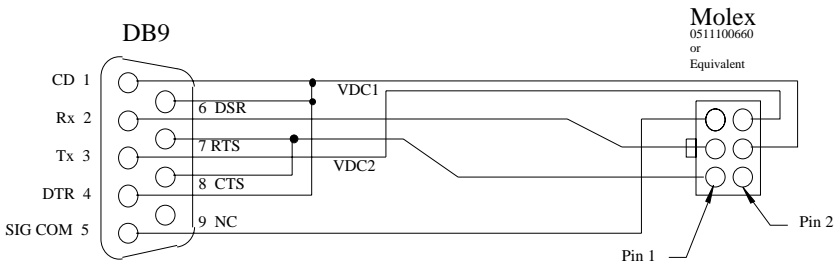

4.6. Wiring

When installing CAT3, it is a good practice to use shielded cables for all input and output signals. The shield should be connected to the earth ground lug on the CAT3. The shield on the opposite end of the cable should be left open.

This wiring practice is mandatory in order to comply with the requirements for Electromagnetic Compatibility, as per EMC-Directive 89/336/EEC of the Council of European Community.

Appendix A – Default Configuration

Factory default configuration:

<i>FIELD</i>	<i>Value</i>
DN	10000000
FC	0 (<i>Average</i>)
KD	3
AK	1.00
NP	20
F01	4999.981
F02	4999.982
F03	4999.983
F04	4999.984
F05	4999.985
F06	4999.986
F07	4999.987
F08	4999.988
F09	4999.989
F10	4999.990
F11	4999.991
F12	4999.992
F13	4999.993
F14	4999.994
F15	4999.995
F16	4999.996
F17	4999.997
F18	4999.998
F19	4999.999
F20	5000.000
K01	1.00
K02	1.00
K03	1.00
K04	1.00
K05	1.00
K06	1.00
K07	1.00
K08	1.00
K09	1.00
K10	1.00
K11	1.00
K12	1.00
K13	1.00
K14	1.00
K15	1.00

20 Appendix A – Default Configuration

<i>FIELD</i>	<i>Value</i>
K16	1.00
K17	1.00
K18	1.00
K19	1.00
K20	1.00
CF	1.000
TU	100 (<i>GAL</i>)
FM	1 (<i>MIN</i>)
NB	01
LF	00000.000
AF	99.999
PS	0 (<i>OFF</i>)
FO	8
UA	Off
AL	99999.981
OC	0 (<i>Rate</i>)
TP	No
AS	No

Appendix B - Communications

Message Format And Timeout

Communication messages consist of a string of ASCII characters terminated by a carriage return character. The maximum message length coming to the CAT3 is 20 characters, including the carriage return. The CAT3 will transmit no more than 35 characters before transmitting a carriage return.

If a message longer than 20 characters sent, the instrument responds with

```
"Command Sequence is Too Long!<NL>"
```

If an unrecognized or invalid command is sent, the instrument responds with

```
"Invalid Command! <NL>"
```

The sending unit RS232C serial port configuration must be configured as follows:

Baud rate:	2400
Data bits:	8
Parity:	none
Stop bits:	1
Handshaking:	none

The CAT3 echoes all received messages and then transmits a response string terminated with a carriage return. If the sending unit takes longer than one minute to send a message, CAT3 aborts the message by clearing the receive buffer.

If the sending unit (PC or other such device) wishes to change a setting on the CAT3, the sending unit shall follow the command with an equal sign (“=”) with the data following immediately after the equal sign. The carriage return terminates the message.

Any CAT3 response that sends data back to the sending unit shall have an equal sign (“=”) followed by the data. Space is allowed between the equal sign and the data on the return message, but the total message length is limited to 35 characters.

READ Example:

If the sending unit wishes to read the number of points that the CAT3 has in the K factor table, the sending unit shall send

"NP<CR>"

The CAT3 echoes the sent message, and responds with

"NUM PTS = 2<CR>"

WRITE Example:

If the sending unit wishes to change the number of points to 20 in the K factor table, the sending unit shall send

"NP=20<CR>"

The CAT3 echoes the sent message and responds with

"NUM PTS = 20<CR>".

The CAT3 checks the ranges for data and rejects writes that are not within the allowed range. If the sending unit sends data that is not within the allowed range, the CAT3 echoes the sent message and responds with the value that is currently stored in the CAT3.

Example:

If the sending unit wishes to change the max sample time to 2000 from the previous setting of 10, the sending unit shall send

"NB=2000<CR>"

The CAT3 echoes the sent message, and responds with

"MAX M TIME= 10<CR>".

Messages

Commands Supported By Communications Messages

Command	Description/Allowed Data/Response
<p>DN</p>	<p>Tag Number "0" to "99999999" "TAG NUM = (DATA)" The first three digits are the units code for total. Changing these digits will change the TU settings.</p>
<p>FC</p>	<p>Linearization "0" = Average K factor "1" = Linearization table "F C METHOD = AVG" for Average K factor or "F C METHOD = LIN" for Linearization table</p>
<p>KD</p>	<p>K Factor Decimal Point Location "0" for 00000000. "1" for 0000000.0 and all K Factors are less than 9999999.9, otherwise not allowed "2" for 000000.00 and all K Factors are less than 999999.99, otherwise not allowed "3" for 00000.000 and all K Factors are less than 99999.999, otherwise not allowed "K-FAC DECL=(DATA)"</p>
<p>AK</p>	<p>Average K Factor "0.001" to "99999.999" if KD = 3 "999999.99" if KD = 2 "9999999.9" if KD = 1 " 99999999" if KD = 0 "AVG KFAC =(DATA)"</p>
<p>NP</p>	<p>Number Points in the Table "2" to "20" "NUM PTS =(DATA)"</p>

Command	Description/Allowed Data/Response
F##	<p>Frequency 1-20</p> <p>F01 has a range of "0.000" to the value of F02 minus 0.001; F20 has a range of the value from F19 plus 0.001 to "5000.000"; Frequencies F02 to F19 must be 0.001 greater than the previous frequency and 0.001 less than the next frequency.</p> <p>"FREQ ## =(DATA)" for F01 through F20. Data to fixed three decimal places.</p>
K##	<p>K-Factor 1-20</p> <p>"K-FACT # =(DATA)" for K01 through K09.</p> <p>"K-FACT ## =(DATA)" for K10 through K20.</p> <p>DATA to decimal places as per KD command.</p>
CF	<p>Correction Factor</p> <p>"0.001" to "9999999.999"</p> <p>"CORR FACT =(DATA)"</p>
TU	<p>Total Units</p> <p>"100" for gallons</p> <p>"140" for liters</p> <p>"110" for cubic feet</p> <p>"150" for cubic meters</p> <p>"180" for barrels</p> <p>All other integer values from 0 and less than 999 will map to custom units</p> <p>"TOT UNITS =(DATA)"</p> <p>(DATA) shall be:</p> <p>"GAL" for gallons</p> <p>"LIT" for liters</p> <p>"FT3" for cubic feet</p> <p>"M3 " for cubic meters</p> <p>"BBL" for barrels</p> <p>"CUS" for custom</p> <p>These three numbers will be the same as the first three digits of the tag number. Changes to this menu shall cause the changes to the tag number.</p>

Command	Description/Allowed Data/Response
FM	Rate Units "0" for seconds "1" for minutes "2" for hours "3" for days "FLOW UNITS=(DATA)" (DATA) shall be: "SEC" for seconds "MIN" for minutes "HR " for hours "DAY" for days
NB	Max Sample Time "1" to "80" "MAX M TIME=(DATA)"
LF	Out Low "0.000" to a maximum value of the Out High setting "4mA FLOW =(DATA)"
AF	Out High Minimum is the Out Low Setting (LF) to a maximum of the following: "99999.999" if RD = 3 "999999.99" if RD = 2 "9999999.9" if RD = 1 " 99999999" if RD = 0 "20mA FLOW =(DATA)"
PS	Pulse Scale "0" for OFF "1" for 1 "10" for 10 "100" for 100 "PULS SCALE=(DATA)" (DATA) shall be: "OFF" for OFF "1" for 1 "10" for 10 "100" for 100

Command	Description/Allowed Data/Response
FO	Pulse Frequency "1" "2" "4" "8" "PULS FREQ = (DATA) "
UA	Alarm Function "0" for OFF "1" for RATE "2" for TOTAL "ALARM FUNC= (DATA) " (DATA) shall be: "OFF" for OFF "RAT" for RATE "TOT" for TOTAL
AL	Alarm Out "0.001" to a maximum defined as follows: If UA is RATE: "99999.999" if RD = 3 "999999.99" if RD = 2 "9999999.9" if RD = 1 " 99999999" if RD = 0 If UA is Total or Off: "99999.999" if TD = 3 "999999.99" if TD = 2 "9999999.9" if TD = 1 " 99999999" if TD = 0 "ALARM OUT = (DATA) "
OC	Current Out "0" - Current output follows rate. "1" - Current output set to 4mA. "2" - Current output set to 12mA. "3" - Current output set to 20mA. For "0", response = " Output equal to input." For "1", response = " Output is 4mA." For "2", response = " Output is 12mA." For "3", response = " Output is 20mA."

Command	Description/Allowed Data/Response
PR	<p>Pulse Output Controlled By PS and FO " Pulse Output Released "</p> <p>The PS and FO menus shall control the pulse output. Used to terminate the TP command.</p>
TP	<p>Output 1Hz Test Frequency for Pulse Output " Test Pulse Output "</p> <p>Sets output to 1Hz, 50% duty cycle signal. This mode is for factory test.</p>
RA	<p>Release Alarm Output for Control According to Menu Settings " Alarm Released "</p> <p>Releases alarm output for control by the alarm output settings.</p>
AS	<p>Alarm Output Test "0" – Alarm output is set low. "1" - Alarm output is set high.</p> <p>For "0", response = " Alarm Active " For "1", response = " Alarm Released "</p> <p>After using the "AS" command, you must initiate a RA command to allow HIT-2A to return to normal operation.</p>

System Commands Supported by Communications Messages

System Command	Description/Response/Comments
OI	Output 4mA " Output is 4mA." Current output set to 4mA.
MO	Output 12mA " Output is 12mA." Current output set to 12mA.
OM	Output 20mA " Output is 20mA." Current output set to 20mA.
OF	Output = Rate (Input) " Output equal to input." Current output follows rate.
AA	Auto Data "F (DATA) R (DATA) T (DATA)" The response, not the echo, is sent every two seconds until it receives another message from the master. The (DATA) following the F denotes the frequency of the pulses to a precision of three places past the decimal, the (DATA) following the R denotes the rate to a precision of three places past the decimal, and the (DATA) following the T denotes the total to a precision of three places past the decimal.
DA	Dump All All of the responses in previous table. The CAT3 gives all responses except for the CL command.
UI	Unit Identification "UNIT MODEL= XX YY.ZZ" Model and software number for the unit. XX is the hardware revision number, YY.ZZ is the software revision where YY is the major software revision and ZZ is the minor software revision.

System Command	Description/Response/Comments
<p>RR</p>	<p>Read Rate "FLOW = (DATA)" (DATA) = "0" to the following maximums: "99999.999" if RD = 3 "999999.99" if RD = 2 "9999999.9" if RD = 1 " 99999999" if RD = 0</p>
<p>CN</p>	<p>Adjust 4mA output point "CN=# (DATA)"</p> <p>(DATA) is the integer value that the HIT2A sends to the 4-20mA converter to output 4mA</p> <p>This parameter is passed to the HIT2A to adjust the 4mA output point of the device. This value is used in production at the test step to calibrate the 4mA output point. "CN" will cause an Invalid Command response and absence of the # symbol will cause the HIT2A to ignore the data.</p>
<p>CM</p>	<p>Adjust 20mA output point "CM=# (DATA)"</p> <p>(DATA) is the integer value that the HIT2A sends to the 4-20mA converter to output 20mA</p> <p>This parameter is passed to the HIT2A to adjust the 20mA output point of the device. This value is used in production at the test step to calibrate the 20mA output point. "CM" will cause an Invalid Command response and absence of the # symbol will cause the HIT2A to ignore the data.</p>
<p>SA</p>	<p>Set Alarm Output On " Alarm Active "</p> <p>Sets the alarm output active regardless of the settings.</p>