

*Model: HRT1*  
*Flow Rate Indicator/Totalizer With*  
*HART® Communications Protocol*

*USER'S MANUAL*



HP-313  
February 2011

**H** **HOFFER FLOW CONTROLS, INC.**  
**PERFECTING MEASUREMENT™**

107 Kitty Hawk Lane • P.O. Box 2145 • Elizabeth City, NC 27906-2145  
1-800-4584 • 252-331-1997 • FAX: 252-331-2886  
[www.hofferflow.com](http://www.hofferflow.com) • E-mail: [info@hofferflow.com](mailto:info@hofferflow.com)





**Certificate of Registration**  
**HCF Verified**

<u>Hoffer Flow Controls</u> Manufacturer	<u>HRT1</u> Product Name / Model Number
<u>006015</u> Manufacturer ID (Hex)	<u>E0A1</u> Device Type (Hex)
<u>7</u> HART Protocol Revision	<u>1</u> Device Revision
<u>1</u> Hardware Revision	<u>2</u> Software Revision
<u>10/03/2008</u> Test Date	<u>HCF</u> Verification Method

The above device has successfully met the quality assurance conditions to be called "HART REGISTERED" and was found to be consistent with the requirements specified by HART Field Communication Protocol

Registration Number: L2-06-1000-046

Registration Issue Date: October 3, 2008

HCF QA Approval:

A handwritten signature in black ink, appearing to read "E. R. H.", is written over the "HCF QA Approval:" label.



HART® is a registered trademark of the HART Communication Foundation



---

## NOTICE

---

Hoffer Flow Controls, Inc. makes no warranty of any kind with regard to this material, including, but not limited to, the implied warranties of merchantability and fitness for a particular purpose.

This manual has been provided as an aid in installing, connecting, calibrating, operating, and servicing this unit. Every precaution for accuracy has been taken in the preparation of this manual; however, Hoffer Flow Controls, Inc. neither assumes responsibility for any omissions or errors that may appear nor assumes liability for any damages that result from the use of the products in accordance with information contained in the manual.

HOFFER FLOW CONTROLS' policy is to provide a user manual for each item supplied. Therefore, all applicable user manuals should be examined before attempting to install or otherwise connect a number of related subsystems.

During installation, care must be taken to select the correct interconnecting wiring drawing. The choice of an incorrect connection drawing may result in damage to the system and/or one of the components.

Please review the complete model number of each item to be connected and locate the appropriate manual(s) and/or drawing(s). Identify all model numbers exactly before making any connections. A number of options and accessories may be added to the main instrument, which are not shown on the basic user wiring. Consult the appropriate option or accessory user manual before connecting it to the system. In many cases, a system wiring drawing is available and may be requested from Hoffer Flow Controls.

This document contains proprietary information, which is protected by copyright. All rights are reserved. No part of this document may be photocopied, reproduced, or translated to another language without the prior written consent of Hoffer Flow Controls, Inc.

HOFFER FLOW CONTROLS' policy is to make running changes, not model changes, whenever an improvement is possible. This affords our customers the latest in technology and engineering. The information contained in this document is subject to change without notice.

THIS WARRANTY IS EXPRESSLY IN LIEU OF ALL OTHER WARRANTIES, EXPRESSED OR IMPLIED, INCLUDING ANY IMPLIED WARRANTY OF MERCHANTABILITY OR FITNESS FOR A PARTICULAR PURPOSE. HFC SHALL NOT BE LIABLE FOR ANY LOSS OR DAMAGE RESULTING, DIRECTLY OR INDIRECTLY, FROM THE USE OR LOSS OF USE OF THE GOODS. WITHOUT LIMITING THE GENERALITY OF THE FOREGOING, THIS EXCLUSION FROM LIABILITY EMBRACES THE PURCHASER'S EXPENSES FOR DOWNTIME OR FOR MAKING UP DOWNTIME, DAMAGES FOR WHICH THE PURCHASER MAY BE LIABLE TO OTHER PERSONS, DAMAGES TO PROPERTY, AND INJURY TO OR DEATH OF ANY PERSONS. HFC NEITHER ASSUMES NOR AUTHORIZES ANY PERSON TO ASSUME FOR IT ANY OTHER LIABILITY IN CONNECTION WITH THE SALE OR USE OF HFC'S GOODS, AND THERE ARE NO ORAL AGREEMENTS OR WARRANTIES COLLATERAL TO OR AFFECTING THE AGREEMENT. PURCHASER'S SOLE AND EXCLUSIVE REMEDY IS THE REPAIR AND/OR REPLACEMENT OF NONCONFORMING GOODS AS PROVIDED IN THE PRECEDING PARAGRAPHS. HFC SHALL NOT BE LIABLE FOR ANY OTHER DAMAGES WHATSOEVER INCLUDING INDIRECT, INCIDENTAL, OR CONSEQUENTIAL DAMAGES.

---

## LIMITED WARRANTY POLICY FOR HOFFER FLOW CONTROLS

---

HOFFER FLOW CONTROLS, INC. ("HFC") warrants HFC's Precision Series and API Series of turbine flowmeters to be free from defects in material and workmanship under normal use and service, only if such goods have been properly selected for the service intended, properly installed and properly operated and maintained as described in the turbine flowmeter manual. Reference "turbine flowmeter manual" for specific details. This warranty shall extend for a period of five (5) years from the date of shipment to the original purchaser and covers the Precision Series and API Series of flowmeters supplied with their standard hybrid ceramic ball bearings only. All other HFC products carry a one (1) year warranty. This warranty is extended only to the original purchaser ("Purchaser"). *Purchaser's sole and exclusive remedy is the repair and/or replacement of nonconforming goods as provided in the following paragraphs.*

In the event Purchaser believes the Hoffer product is defective, the product must be returned to HFC, transportation prepaid by Purchaser, within the appropriate warranty period relative to the product. If HFC's inspection determines that the workmanship or materials are defective and the required maintenance has been performed and, has been properly installed and operated, the product will be either repaired or replaced, at HFC's sole determination, free of additional charge, and the goods will be returned, transportation paid by HFC, using a transportation method selected by HFC.

Prior to returning the product to HFC, Purchaser must obtain a Returned Material Authorization (RMA) Number from HFC's Customer Service Department within 30 days after discovery of a purported breach of warranty, but not later than the warranty period; otherwise, such claims shall be deemed waived. See the Return Requests/inquiries Section of this manual.

If HFC's inspection reveals the Hoffer product to be free of defects in material and workmanship or such inspection reveals the goods were improperly used, improperly installed, and/or improperly selected for service intended, HFC will notify the purchaser in writing and will deliver the goods back to Purchaser upon receipt of Purchaser's written instructions and agreement to pay the cost of transportation. If Purchaser does not respond within thirty (30) days after notice from HFC, the goods will be disposed of in HFC's discretion.

HFC does not warrant the product to meet the requirements of any safety code of any state, municipality, or other jurisdiction, and Purchaser assumes all risk and liability whatsoever resulting from the use thereof, whether used singly or in combination with other machines or apparatus.

This warranty shall not apply to any HFC product or parts thereof, which have been repaired outside HFC's factory or altered in any way, or have been subject to misuse, negligence, or accident, or have not been operated in accordance with HFC's printed instructions or have been operated under conditions more severe than, or otherwise exceeding, those set forth in the specifications.

---

FOR **NON-WARRANTY** REPAIRS OR **CALIBRATIONS**, consult HOFFER FLOW CONTROLS for current repair/calibration charges. Have the following information available BEFORE contacting HOFFER FLOW CONTROLS:

1. P.O. number to cover the COST of the repair/calibration,
  2. Model and serial number of the product, and
  3. Repair instructions and/or specific problems relative to the product.
-

# CONTENTS

<b>1. INTRODUCTION</b>	<b>1</b>
Model Number Designation	3
<b>2. SPECIFICATIONS AND PRODUCT FEATURES</b>	<b>5</b>
2.1 General	5
2.2 Inputs	6
2.3 DC Power/Loop Powered	6
2.4 Analog Output	7
2.5 Pulse Output	7
2.6 Alarm 1 and Alarm 2	7
2.7 Physical	7
Product Features	8
<b>3. INSTALLATION</b>	<b>9</b>
3.1 4-20 mA Current Loop	11
3.2 Flowmeter Input	12
3.3 Pulse Output	14
3.4 Alarm Outputs	14
3.5 Wiring Summary	16
<b>4. CONFIGURATION</b>	<b>17</b>
4.1 Local Configuration	17
4.2 Default Configuration	20
<b>5. OPERATION AND MAINTENANCE</b>	<b>21</b>
5.1 Display Parameters	21
5.2 Saving Grand Total	21
5.3 Clearing the Total	21
5.4 System Response Time	22
5.5 Error Conditions	22
5.6 Battery Replacement	23
<b>6. HART COMMUNICATIONS</b>	<b>25</b>
6.1 Dynamic Variables	25
6.2 Universal Commands	26
6.3 Common-Practice Commands	26
6.4 Device-Specific Commands	27
6.5 Device Status	29
6.6 Additional Device Status	30
6.7 EDDL – Process Variables	33
6.8 EDDL – Device Diagnostics	34
6.9 EDDL – Online	34
<b>APPENDIX A – DEFAULT CONFIGURATION</b>	<b>39</b>



## 1. INTRODUCTION

The HRT1 is a loop-powered microprocessor-based flow rate indicator and totalizer with HART Field Communications Protocol. The instrument can accept a low-level signal from a magnetic type pickup coil, logic level pulse signal, or contact closure on the signal input. Pulses from the signal input are counted and converted into volume and rate values based on flowmeter calibration settings in the instrument. The total volume and flow rate is displayed on a two-line liquid crystal display (LCD). The top line is an 8-digit Total Volume display and the bottom is a 5-digit Rate display. A 4-20 mA analog signal proportional to the flowrate is output on the current loop. The HRT1 is configurable by way of the instrument keypad or via HART communications.



Figure 1 – HRT1 Front Panel Overview

Optional features include 20-point linearization to correct for flowmeter non-linearities, a Scaled Pulse Output and 2 Alarm Outputs configurable for Rate or Total.

The instrument may be housed in a NEMA 4X polycarbonate enclosure, which may be wall mounted or directly mounted on a flowmeter using an optional riser. Other options include panel mount or an EX proof enclosure for hazardous areas.

This instrument is designed to conform to the EMC-Directive of the Council of European Communities 89/336/EEC and the following standards:

*Generic Emission Standard EN 61000-6-3*

Residential, Commercial & Light Industry Environment.

*Generic Immunity Standard EN 61000-6-1*

Residential, Commercial & Light Industry Environment.

*Electrostatic discharge requirements EN 61000-4-2*

*Radiated, radio-frequency, electromagnetic immunity EN 61000-4-3*

*Electrical fast transient/burst requirements EN 61000-4-4*

*Immunity to conducted disturbances EN 61000-4-6*

---



---

**MODEL NUMBER DESIGNATION**

---

**MODEL HRT1  
FLOW RATE INDICATOR/TOTALIZER  
WITH HART® COMMUNICATIONS PROTOCOL**

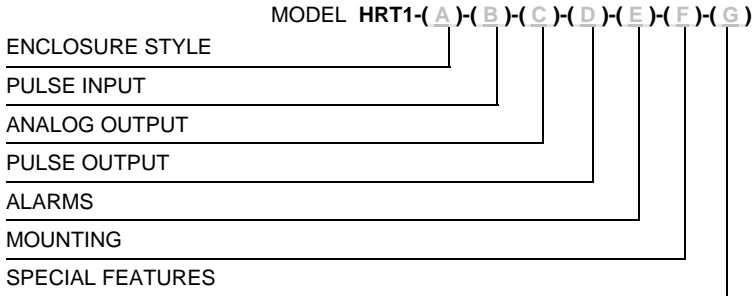
**ENCLOSURE STYLE**

MODEL HRT1-(A)-( )-( )-( )-( )-( )-( )

**OPTION ( A )**

- (2) NEMA 4X ENCLOSURE  
(HRT1 MOUNTED BEHIND CLEAR COVER)
- (3) EXPLOSION-PROOF HOUSING  
CLASS I, DIVISION I, GROUPS B, C AND D  
CLASS II, DIVISION I, GROUPS E, F AND G
- (3A) ATEX Exd ENCLOSURE, STANDARD BLUE
- (3B) ENCLOSURE FOR BRAZIL, GRAY
- (P) PANEL MOUNT ENCLOSURE.
- (PD) PANEL MOUNT ENCLOSURE WITH CLEAR DOOR AND LOCK
- (4) NEMA 4X ENCLOSURE  
(HRT1 MOUNTED TO THE OUTSIDE OF CLEAR COVER)

**PULSE INPUT**

MODEL HRT1-( )-(B)-( )-( )-( )-( )-( )-( )

**OPTION ( B )**

- (M) MAGNETIC COIL, PULSE, DRY CONTACT.
- (R) ISOLATED PULSE, RPM, RPR, HALL EFFECT COILS.

**ANALOG OUTPUT**

MODEL HRT1-( )-( )-(C)-( )-( )-( )-( )-( )

**OPTION ( C )**

- (W) WIRED 4-20MA LOOP POWERED
- (T) WIRELESS 4-20 MA OUTPUT

**PULSE OUTPUT**

MODEL HRT1-( )-( )-( )-(D)-( )-( )-( )-( )

**OPTION ( D )**

- (5) 0-5V TTL/CMOS
- (OC) OPEN COLLECTOR
- (V) PULLUP TO VDC+ IN (8-30VDC)

## Introduction 4

**ALARMS** - TWO OPTO-ISOLATED ALARMS WITH USER-DEFINED LEVELS FOR RATE AND/OR TOTAL

MODEL HRT1-( )-( )-( )-( )-(E)-( )-( )

OPTION ( E )

- (5) 0-5V TTL/CMOS
- (OC) OPEN COLLECTOR
- (V) PULLUP TO VDC+ IN (8-30VDC)

### **MOUNTING**

MODEL HRT1-( )-( )-( )-( )-( )-(F)-( )

OPTION ( F )

- (F) NEMA 4X STYLE 2 ENCLOSURE MOUNTED ON TURBINE. MUST BE USED WITH "X" RISER TURBINE OPTION.
- (FHT) 8" LONG TEMPERATURE RISER FOR NEMA 4X STYLE 2 ENCLOSURE MOUNTED ON TURBINE. REQUIRED WHEN FLUID TEMPERATURES EXCEED 140 DEG. F. MUST BE USED WITH "X" RISER TURBINE OPTION.
- (FX) EXPLOSION-PROOF STYLE 3 ENCLOSURES MOUNTED ON TURBINE. MUST BE USED WITH "X" RISER TURBINE OPTION.
- (FXHT) 8" LONG TEMPERATURE RISER FOR EXPLOSION-PROOF STYLE 3 ENCLOSURES MOUNTED ON TURBINE. REQUIRED WHEN TEMPERATURES EXCEEDS 140 DEG. F. MUST BE USED WITH "X" RISER TURBINE OPTION.
- (NP) NEMA 4X ENCLOSURE PIPE MOUNTING KIT, 2" PIPE OR SMALLER. SPECIFY IF PIPE IS VERTICAL OR HORIZONTAL.

### **SPECIAL FEATURES**

MODEL HRT1-( )-( )-( )-( )-( )-( )-(G)

OPTION ( G )

- (CE) CE MARK REQUIRED FOR EUROPE
- (SP) ANY SPECIAL FEATURES THAT ARE NOT COVERED IN THE MODEL NUMBER USE A WRITTEN DESCRIPTION OF THE -SP.

## 2. SPECIFICATIONS AND PRODUCT FEATURES

### General Specifications

#### 2.1 General

Display:	LCD, updated every 2.0 seconds.
Total:	8 digits 0.26" high. Resettable using a magnet, a contact closure to power common on the RESET input terminal, from the front panel keypad or via HART communications.
Total Units:	GAL, LIT, FT3, M3, BBL, & "blank".
Grand Total:	8 digits 0.26" high, non-resettable. Value stored once per minute in non-volatile memory. Grand Total is displayed for 15 seconds after pressing the ▲ button.
Rate:	5 digits 0.5" high.
Rate Units:	/SEC, /MIN, /HR, & /DAY
K-factor:	The pulses per unit of Total (e.g. pulses/gallon) are configurable in the range 0.001 to 99,999,999.
Linearization:	Up to 20 points.
Decimal Points:	Decimal Point positions are configurable for 0, .0, .00, or .000 for both rate and total.
Accuracy:	Total: $\pm 1$ count, Rate: $\pm 0.01\%$

## 2.2 Inputs

### ***Magnetic Pickup:***

Frequency Range: 0.2 Hz to 5000 Hz.  
 Signal Level: 30 mV<sub>P-P</sub> to 30 V<sub>P-P</sub>.

### ***Opto-Isolated DC Pulse:***

Frequency Range: 0 Hz to 5000 Hz.  
 Signal Type: DC pulse.  
     High (Logic 1): 4 to 30 VDC  
     Low (Logic 0): < 1 VDC  
 Min Pulse width: 0.1 msec

### ***Contact Closure:***

Frequency Range: 0 Hz to 5000 Hz  
 Signal Type: Contact closure, Sig+ Terminal to DC common  
 Internal Pull-up: 220 kΩ to +3.3 VDC

### ***Reset:***

Signal Type: Contact closure, Reset Terminal to DC common  
     Min On: 25 msec  
 Internal Pull-up: 100 kΩ to +3.3 VDC  
 External Magnet: Activates internal reed switch

## 2.3 DC Power/Loop Powered

Voltage: 8 to 30 VDC  
 Current: < 24 mA  
 Loop Burden: 8 VDC maximum  
 Supply Backup: One (1) C-size 3.6V Lithium battery  
 Battery Life: 6 years typical  
 Protection: Reverse polarity protected

## 2.4 Analog Output

Scale:	4 – 20 mA follows rate.
Accuracy:	0.02% of Full Scale @ 20°C.
Temperature drift:	40 ppm/°C
Update Time:	2.0 seconds.
Connection:	Two wire.
Protection:	Reverse polarity protected

## 2.5 Pulse Output

Type:	0-5V TTL, 0-Supply Voltage, Open collector (30 VDC, 100 mA)			
Divider:	1, 10, 100, or OFF			
Rate & Duration:	See below.			

SPEED (Hz)	1	2	4	8
On/Off (msec)	500	250	125	62.5

## 2.6 Alarm 1 and Alarm 2

Type:	0-5V TTL, 0-Supply Voltage, Open collector (30 VDC, 100 mA)
Function:	Rate or Total

## 2.7 Physical

Temperature:	Operating: -4 °F (-20°C) to 158 °F (70 °C).
Humidity:	0 – 90% Non-condensing.
Packaging:	NEMA 4X, Panel mount or Explosion proof
Dimensions for NEMA 4X enclosure:	4.33" (110 mm) wide x 4.33" (110 mm) long 4.33" (110 mm) tall.

## Product Features

- HART Field Communications Protocol, Revision 7.0
- LCD display
- 8-Digit Total display with configurable decimal point location
- 5-Digit Rate display with configurable decimal point location
- 8-Digit, Non-resettable Grand Total display
- 4-button membrane keypad
- Pulse Input supports turbine as well as many other pulse generating flowmeters
- Up to 20-Point Linearization to correct for flowmeter non-linearities
- 4-20 mA analog output proportional to flow rate
- Optional Scaled Pulse Output representing an increment of volume for each pulse
- 2 Optional Alarm Outputs configurable for Rate or Total
- Magnetically operated reed switch for Total reset
- Internal 3.6V C-Size battery backup
- Configuration and Grand Total stored in non-volatile memory. Grand Total saved once per minute.

### 3. INSTALLATION



**Warning: When contained in an Explosion-Proof enclosure, do not open the cover while circuits are live in hazardous atmospheres.**

#### Field Wiring Connections

Connections are made to the HRT1 on two six-position terminal blocks, labeled as terminals 1-12 (Fig. 3.1). A ten-position DIP switch (SW2) located on the back of PCA186A provides a quick selection of various input/output options. The following pages illustrate connections and switch settings for various options.

To make field wiring connections to the HRT1-4 option (NEMA 4X, front panel mounted on the outside of the clear cover), complete the following:

1. Loosen the four cover screws.
2. Remove the clear cover and HRT1 assembly.
3. Use a small flat blade screwdriver and turn counter-clockwise to loosen the proper terminal screw.
4. Insert wire and turn terminal screw clockwise to tighten.
5. Lightly pull on wire to ensure proper connection.

For the HRT1-2 option (NEMA 4X, front panel mounted behind the clear cover):

1. Loosen the four cover screws and remove the clear cover.
2. Remove the four #4-40 x 5/16" black oxide screws from the corners of the panel and remove the HRT1 assembly.
3. Use a small flat blade screwdriver and turn counter-clockwise to loosen the proper terminal screw.
4. Insert wire and turn terminal screw clockwise to tighten.
5. Lightly pull on wire to ensure proper connection.

For the HRT1-3 or HRT1-3A option (Explosion proof enclosure):

1. Unscrew the cover of the enclosure counter-clockwise until it separates from the body of the enclosure.
2. Remove the two #4-40 x 1" black oxide screws from the top left and bottom right section of the front panel.
3. Remove the HRT1 assembly from the mounting standoffs.
4. Use a small flat blade screwdriver and turn counter-clockwise to loosen the proper terminal screw.
5. Insert wire and turn terminal screw clockwise to tighten.
6. Lightly pull on wire to ensure proper connection.

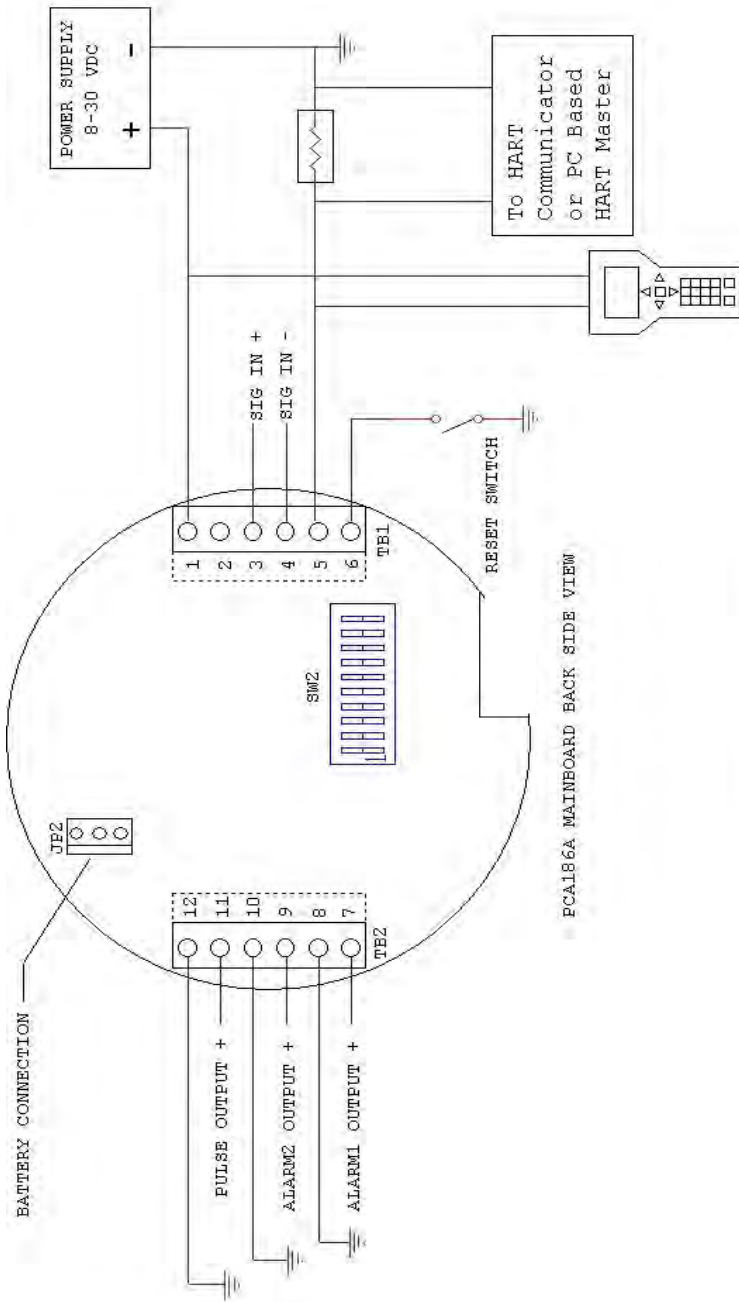

Figure 3.1 - HRT1 Wiring Detail

### 3.1 4-20 mA Current Loop

The HRT1 is powered from a two-wire 4-20 mA current loop, in the voltage range of 8-30 Volts DC, depending on the loop resistance. One C-Size 3.6V Lithium battery is included as a backup power supply to ensure that volume accumulation will not be interrupted during a power failure. Switch 2 of SW-2 must be ON for loop power.

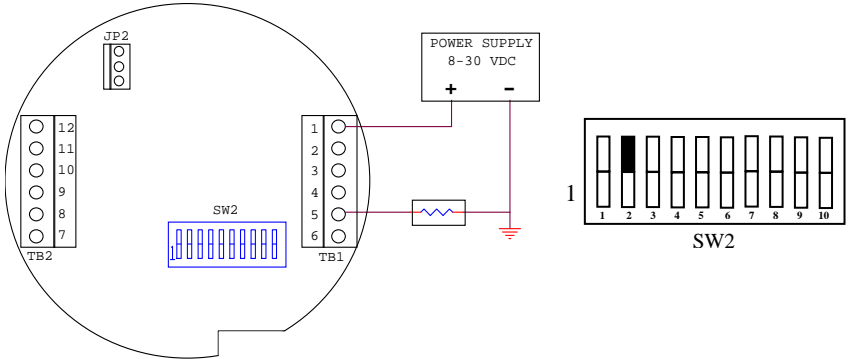

Figure 3.1.1 – 4-20mA Loop Wiring and Switch Settings

#### Supply Voltage VS Load

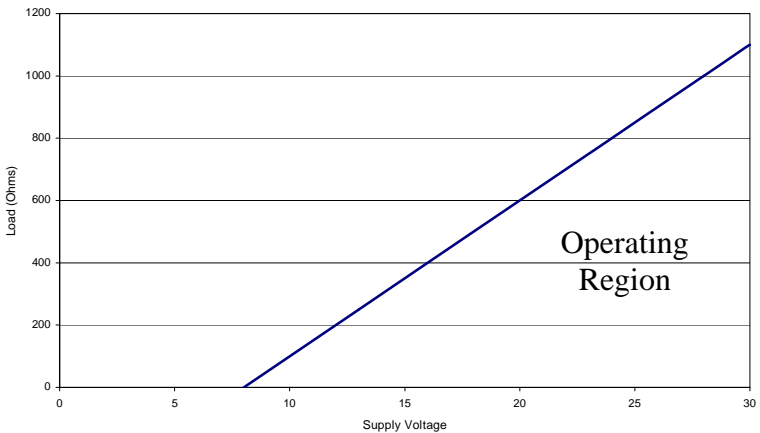

Figure 3.1.2 – Loop Load Limitations

**NOTE:**  
**HART Communications requires a loop resistance between 250 and 1100 Ohms.**

The HRT1 outputs a 4-20mA analog signal on the current loop that is proportional to the calculated flow rate. The 4mA and 20mA settings referred to as **OUTLO** and **OUTH**; respectively, may be configured from the front panel of the instrument or via HART communications.

### 3.2 Flowmeter Input

The flowmeter input accepts a low-level sinusoidal signal from a magnetic type pickup coil, contact closure, or an isolated DC pulse signal. Switches 7, 8, 9 and 10 on SW-2 must be set according to the type of flowmeter input to be used. Proper switch settings will be made at the factory if the flowmeter input is specified at the time of order.

SW-2 SWITCH SETTINGS FOR FLOWMETER INPUT OPTIONS:

INPUT OPTION	SW-2 SETTINGS
Mag pickup / Contact Closure	7, 8 AND 9 ON (10 OFF)
Isolated Redi-Pulse - TTL	10 ON (7, 8 AND 9 OFF)
Isolated Redi-Pulse – Open-Collector	10 ON (7, 8 AND 9 OFF)

#### Magnetic Pickup Coil/Contact Closure

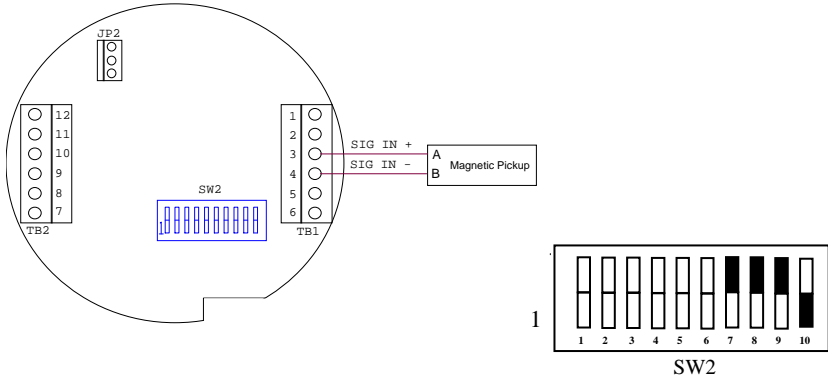

Figure 3.2.1 – Magnetic Pickup/Contact Closure Wiring and Switch Settings

Isolated Redi-Pulse (TTL Pulse)

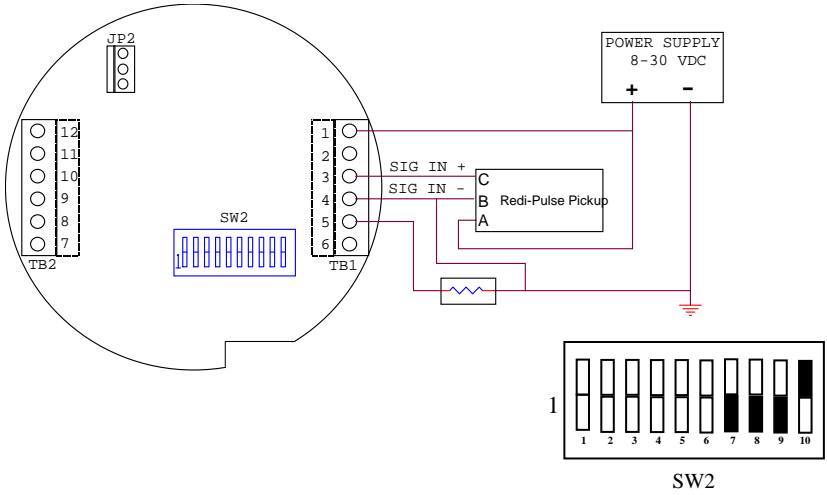

Figure 3.2.2 – Isolated Redi-Pulse TTL Wiring and Switch Settings

Isolated Redi-Pulse (Open Collector)

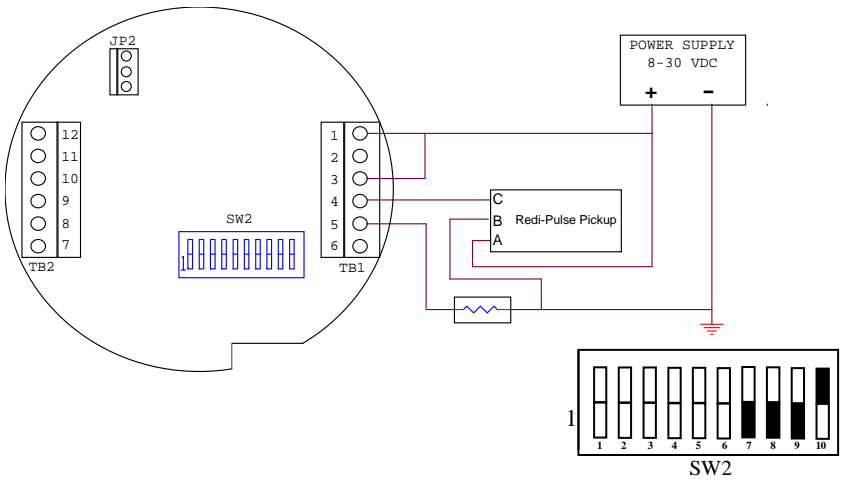

Figure 3.2.3 – Isolated Redi-Pulse Open-Collector Wiring and Switch Settings

### 3.3 Pulse Output

HRT1 Pulse Output can be configured for turbine raw frequency or for unit of measure scaled for the least significant digit of the displayed total. A scaling factor of 1, 10 or 100 is available to reduce or increase the resolution of the pulse output. For example, if the Total Decimal Point is set to 0000000.0, and the Pulse Scale is 1, then 1 pulse will be output for each tenth (0.1) of a unit of measure. Changing the Pulse Scale to 10, would result in an output pulse for each 1.0 unit of measure. The output must be scaled so that the pulse frequency does not exceed the Pulse Frequency setting (8 Hz. Max) at the maximum flow rate.

The Pulse Output may be configured as an Open Collector, 0-5V (TTL) or Internal pullup to VDC+ using dip switch SW-2.

SW-2 SETTINGS AND PROTECTION DIODE VALUE FOR PULSE OUTPUT OPTIONS:

OPTION	SW-2 SETTINGS	TS1
OPEN COLLECTOR	6 OFF	36V TRANSORB
TTL	6 ON	5.1V ZENER
PULLUP TO VDC+	6 ON	36V TRANSORB

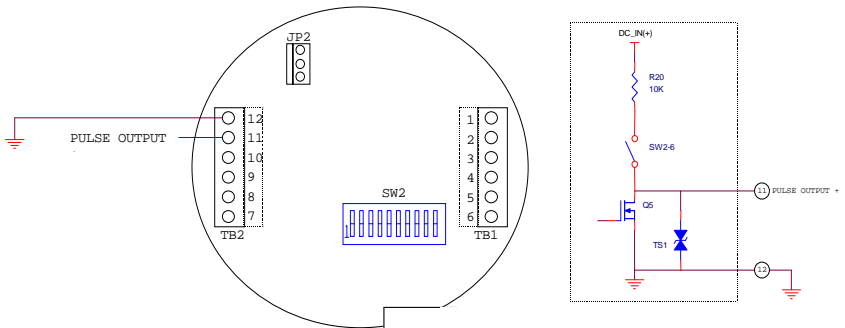

Figure 3.3.1 – Pulse Output Wiring and Circuit Overview

### 3.4 Alarm Outputs

HRT1 provides an optional Alarm Output feature, which includes 2 alarm outputs configurable for Rate or Total. The outputs may be configured as an Open Collector, 0-5V (TTL) or Internal pullup to VDC+.

SW-2 SETTINGS AND PROTECTION DIODE VALUES FOR ALARM OUTPUT OPTIONS:

OPTION	ALARM1 SW-2 SETTINGS	ALARM1 TS5	ALARM2 SW-2 SETTINGS	ALARM2 TS2
OPEN COLLECTOR	4 OFF	36V TRANSORB	5 OFF	36V TRANSORB
TTL	4 ON	5.1V ZENER	5 ON	5.1V ZENER
PULLUP TO VDC+	4 ON	36V TRANSORB	5 ON	36V TRANSORB

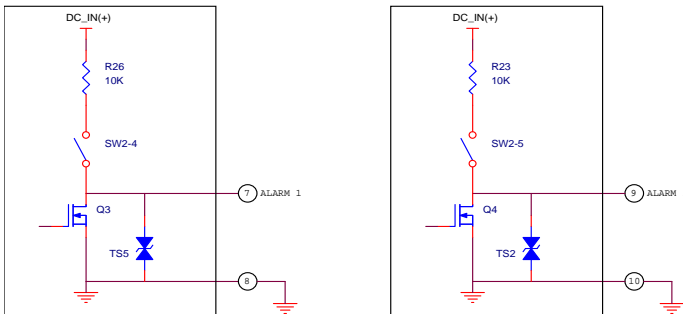

Figure 3.4.1 – Alarm Outputs Circuit Overview

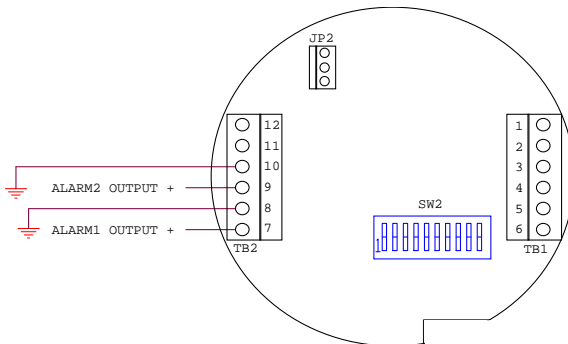

Figure 3.4.2 – Alarm Outputs Wiring

### **3.5 Wiring Summary**

When installing HRT1, it is a good practice to use shielded cables for all input and output signals. The shield should be connected to the chassis ground lug on the HRT1. The shield on the opposite end of the cable should be left open.

This wiring practice is mandatory in order to comply with the requirements for Electromagnetic Compatibility, as per EMC-Directive 89/336/EEC of the Council of European Community.

## 4. CONFIGURATION

The HRT1 is fully configurable, with all parameters being stored in non-volatile memory. The instrument may be configured locally using the front panel keys or remotely via a HART communicator.

### 4.1 Local Configuration

The local configuration mode is entered by pressing the **P** button. Each consecutive press moves to the next menu item. The functions for each button in the configuration mode are described below.

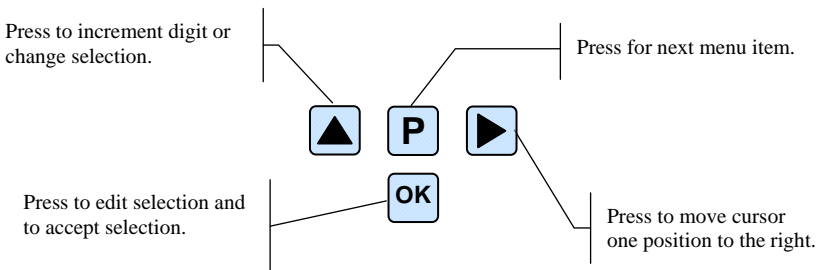

The following table outlines all menu items in the configuration mode:

<i>Display</i>	<i>Option</i>	<i>Menu item Description</i>
CLEAR-tot no	Yes No	<b>Clear Total</b> Clears accumulated total and sets TOTAL display to zero.
:00000000 tR9		<b>Tag Number</b> User defined 8-digit serial number.
RJE-RSE FRC nn	Linear Average	<b>Linearization Method</b> Sets the flow calculation method to average K-factor or K-factor table.
00000.000 FRC d	00000000 0000000.0 000000.00 00000.000	<b>K-factor Decimal Point</b> Set K-factor decimal point location.

<i>Display</i>	<i>Option</i>	<i>Menu item Description</i>
:000 R FAC	8-digit number	<b>Average K-factor</b> Enter average K-factor.
Points 20	2 to 20	<b>Number of Points</b> Sets the number of entries in the linearization table.
4999.98: Fr 0:	0 to 5000	<b>Frequency 1-20</b> Enter a frequency in Hz for each entry in the table. Decimal point is fixed.
:000 FAC0:	8-digit number	<b>K-factor 1-20</b> Enter a k-factor in pulses/gal for each entry in the table.
:000 C FAC	0.001 to 99999.999	<b>Correction Factor</b> User defined number between 0.001 and 99999.999 to multiply flow and total. Default 1.0.
tot unit :00	100 = GAL 110 = FT3 140 = LIT 150 = M3 180 = BBL	<b>Total Units</b> Select Total units. If custom is selected all indicators are off. (gal, lit, ft3, m3, bbl, custom)
0000000.0 tot d	0000000 0000000.0 000000.00 00000.000	<b>Total Decimal Point</b> Set Total decimal point location.
Flow nn in	SEC Min HrS dAY	<b>Rate Units</b> Select RATE units.
00000.000 FL d	0000000 0000000.0 000000.00 00000.000	<b>Rate Decimal Point location</b> Set Rate decimal point location.

<i>Display</i>	<i>Option</i>	<i>Menu item Description</i>
<p><b>SAMPLE</b> <b>:</b></p>	<p>1 to 80</p>	<p><b>Max Sample Time</b> Set maximum time in tenths of a second to sample the input frequency. This setting determines the amount of time the HRT1 will wait for the next input pulse before returning to 0. For example, 80 = 8 seconds. Default is 1. Changing this setting is only recommended for low flow applications below 1 Hz.</p>
<p><b>:000</b> <b>OUTLO</b></p>		<p><b>Out Low</b> Sets flow rate value for 4 mA output.</p>
<p><b>99.999</b> <b>OUTH:</b></p>		<p><b>Out High</b> Sets flow rate value for 20 mA output.</p>
<p><b>PULSE S</b> <b>OFF</b></p>	<p>oFF 1 10 100</p>	<p><b>Pulse Scale</b> Sets scale for pulse out. 1, 10, 100 units of total for one pulse out. Pulses are scaled according to the least significant digit of the displayed total. For example, if Total Decimal places is set to 0000000.0, and Pulse Scale is 1, then 1 pulse is output for each tenth (0.1) of a unit. Changing the Pulse Scale to 10 would output one (1) pulse for every 1.0 unit of volume. OFF- turns pulse out off.</p>
<p><b>PULSE F</b> <b>8</b></p>	<p>1 2 4 8</p>	<p><b>Pulse Frequency</b> Sets frequency of burst of pulse out. (1, 2, 4, 8)</p>
<p><b>PRSS</b> <b>:234</b></p>	<p>0000 to 9999</p>	<p><b>Password</b> Sets 4-digit password. Default 0000.</p>
<p><b>unit Loc</b> <b>no</b></p>	<p>Yes No</p>	<p><b>Lock Unit</b> Locks the unit. Password entry is required to unlock the unit or make any configuration changes after the unit is locked.</p>

<i>Display</i>	<i>Option</i>	<i>Menu item Description</i>
ALn 1 OFF	oFF rAtE tot	<b>Alarm1 Function</b> Select Rate or Total for alarm output. OFF- turns alarm function off.
:00000.0 ALn 1		<b>Alarm1 Value</b> Sets value to activate the alarm output. Default 99999.999
ALn 2 OFF	oFF rAtE tot	<b>Alarm2 Function</b> Select Rate or Total for alarm output. OFF- turns alarm function off.
:00000.0 ALn 2		<b>Alarm2 Value</b> Sets value to activate the alarm output. Default 99999.999
0.0 SEt t		<b>Set Total</b> Sets Total to user defined value. Grand Total is not affected.
Cur out rAtE	rAtE 4 12 20	<b>Current Out</b> Sets analog output to follow rate or a predefined level for loop diagnostics.
PUL tEst no	Yes No	<b>Pulse Output Test</b> Outputs a test frequency of 1Hz, 50% duty cycle.
AL 1 tEst no	Yes No	<b>Alarm1 Output Test</b> Activates alarm1 output.
AL 2 tEst no	Yes No	<b>Alarm2 Output Test</b> Activates alarm2 output.

## 4.2 Default Configuration

HRT1 is fully configured by the factory prior to shipment. When the instrument is purchased with a Hoffer Flowmeter or when calibration and configuration data are supplied, the instrument is configured as specified. When calibration or configuration data is not available, the instrument is shipped with default values. Refer to Appendix A for a listing of the HRT1 factory default configuration.

## 5. OPERATION AND MAINTENANCE

### 5.1 Display Parameters

The HRT1 calculates and displays total volume and flow rate on a two-line liquid crystal display (LCD). The top line is an 8-digit Total Volume display and the bottom is a 5-digit Rate display. The 8-digit non-resettable Grand Total is also viewed on the top line by pressing 

The Grand Total will be displayed for approximately 15 seconds before returning to the Total Volume display.

Volume units and the time base for flow rate are indicated by icons on the right hand side of the LCD. When no icon for time units is displayed, the time base is /SEC.

A Bar graph located at the bottom of the LCD provides a graphical representation of the flow rate based on a percentage of the maximum flow setting.

The flow rate and flow total are calculated and updated on the display once every 2 seconds.

### 5.2 Saving Grand Total

To minimize the number of write cycles to non-volatile memory, the Grand Total is saved once per minute. In the event that both loop power and battery power are removed simultaneously, the Total will be lost and the Grand Total could be up to one minute old when restoring power. When changing the battery (see section 5.6 Battery Replacement), it is recommended to stop the flow at least two minutes prior to removing power from the unit to ensure that the stored Grand Total is current when restoring power.

### 5.3 Clearing the Total

The Volume Total may be cleared by using a magnet, a contact closure to power common on the RESET input terminal, from the front panel keypad or via HART communications (See Chapter 6 HART Communications).

To clear the total using a magnet, slide the magnet slowly across the HRT1 model name at the top of the front panel overlay.

To reset the total from the front panel keypad, use the following key sequence:

Press <b>P</b>	CLEARtot is displayed
Press <b>OK</b>	To enter edit mode.
Press <b>▲</b>	To select yes
Press <b>OK</b>	To clear total
Press <b>▲</b>	To return to operating mode

## 5.4 System Response Time

The displayed Rate and Total are updated every two seconds. The analog output response time to reach steady state due to a change in the input is also approximately two seconds.

The time for the display to reach 0 and for the analog output to return to 4 mA when flow stops will be between 3 and 12 seconds, depending on the Max Sample Time setting (MST). Changing the MST is only recommended for low flow applications where the input frequency is below 1 Hz. See Chapter 4 Configuration for more information on Max Sample Time.

## 5.5 Error Conditions

The HRT1's self-checking capability is used to detect and report malfunctions by displaying error messages on the LCD. When an error occurs, the display will flash an error message until the error condition is eliminated, or the user presses the OK button to acknowledge the condition. Once the error condition has been acknowledged by pressing OK, the error message will stop flashing. The message will be displayed again after 60 seconds if the condition that caused the error has not been resolved. The message will automatically stop flashing and any associated alarms reset once the error condition is no longer present.

The following table outlines the detected conditions and recommended corrective action:

ERROR MESSAGE	CAUSE	CORRECTIVE ACTION
<b>EPULSE</b>	Pulse output exceeds Pulse Frequency setting. Output pulses will stop during this condition.	<ul style="list-style-type: none"> <li>- Change pulse scale.</li> <li>- Increase Pulse Frequency setting(Max 8 Hz).</li> <li>- Reduce the number of places after the Total decimal point.</li> </ul>
<b>EE-ES</b>	EEPROM reset to factory defaults.	Consult factory
<b>E-RLE</b>	Flow rate exceeds the flow rate display capability. Displayed flow rate will consist of all 9s.	Reduce flow rate or reduce the number of places after the flow rate decimal point
<b>EFL0</b>	Flow rate exceeds the 20 mA max flow setting. Analog output will saturate at 24 mA.	Reduce flow rate or increase the 20 mA max flow setting.
<b>LG BATT</b>	Low battery.	Replace battery

### 5.6 Battery Replacement

The only maintenance required for the HRT1 is a possible battery replacement after several years in service.

The instrument has circuitry designed to monitor the battery voltage and illuminate a **LG BATT** message on the LCD when the battery is approaching the end of its life.

When changing the battery, it is recommended to stop the flow at least two minutes prior to removing power from the unit to ensure that the stored Grand Total is current when restoring power (see section 5.2 Saving Grand Total).

This Page Intentionally Left Blank

## 6. HART COMMUNICATIONS

*The HRT1 has been designed to comply with Revision 7.0 of the HART protocol. A full list of features new to Revision 7.0 may be obtained at the Hart Communication Foundation website.*

The HRT1 may be identified by the following:

**Manufacturer ID Code: 224 (E0 Hex)**  
**Device Type Code: 161 (A1 Hex)**

A HART Communicator or HART Master may be used to configure, monitor process variables and obtain diagnostic information from the HRT1. The instrument must be equipped with the HART Modem Board (PCA187), which plugs into a 10-pin connector on the backside of the HRT1 Main Board (PCA186).

Refer to Chapter 3 Installation for information on connections to HART devices.

HART functions are defined as part of an enhanced device description language (EDDL). Contact the factory if the HRT1 device is not available in the list of DD libraries.

### 6.1 Dynamic Variables

The following Dynamic Variables have been implemented:

	Meaning	Units
Primary Variable	Flow Rate	<u>Volume</u> - Gal, Lit, Ft3, M3, Bbl, Custom <u>Time</u> - /Day, /Hour, /Min, /Sec
Secondary Variable	Flow Total	Follows PV Volume units
Tertiary Variable	Grand Total	Follows PV Volume units
Quaternary Variable	Frequency	Hz

## 6.2 Universal Commands

The following Universal Commands have been implemented:

- 0 Read Unique Identifier
- 1 Read Primary Variable
- 2 Read Primary Variable Current and Percent Range
- 3 Read Dynamic Variables and Primary Variable Current
- 6 Write Polling Address
- 7 Read Loop Configuration
- 8 Read Dynamic Variable Classifications
- 9 Read Device Variables with Status
- 11 Read Unique Identifier with Tag
- 12 Read Message
- 13 Read Tag Descriptor Date
- 14 Read Primary Variable Sensor Info
- 15 Read Primary Variable Output Info
- 16 Read Final Assembly Number
- 17 Write Message
- 18 Write Tag Descriptor Date
- 19 Write Final Assembly Number
- 20 Read Long Tag
- 21 Read Unique identifier with Long Tag
- 22 Write Long Tag

## 6.3 Common-Practice Commands

The following Common-Practice Commands have been implemented:

- 35 Write Range Values
- 38 Reset "Configuration Changed" Flag
- 40 Enter/Exit Fixed Current Mode
- 42 Perform Master Reset
- 45 Trim DAC Zero
- 46 Trim DAC Gain
- 48 Read Additional Device Status

## 6.4 Device-Specific Commands

The following Device-Specific Commands have been implemented:

#	COMMAND	DESCRIPTION
128	Read Decimal Point Location	Read the decimal point location for Rate and Total.
129	Write Rate Decimal Point Location	Select displayed flow rate resolution as 00000, 0000.0, 000.00 or 00.000.
130	Write Total Decimal Point Location	Select displayed total resolution as 00000000, 0000000.0, 000000.00 or 00000.000.
131	Clear Total	Reset the Total to zero.
132	Set Total	Set the Total to a user defined value.
133	Read Linearization Variables	Read the flowmeter linearization parameters.
134	Write Linearization	Set flowmeter linearization method as Average K-Factor or Linearization Table.
135	Write K-Factor Decimal Point	Select k-factor resolution as 00000000, 0000000.0, 000000.00 or 00000.000.
136	Write Average-K Factor	Write the value of the Average K-Factor. Valid entries are between 0.001 and 99999999.
137	Write Number of Points	Write the number of points in the Linearization Table. 20 is the max number of points.
138	Write Correction Factor	Write the value of the Correction Factor. The correction factor is a multiplier used to correct flow rate and total.
139	Read Linearization Table	Read the flowmeter Linearization Table.

#	COMMAND	DESCRIPTION
140	Write Linearization Frequency	Write the Frequency values for the linearization table points.
141	Write Linearization K-Factor	Write the K-Factor values for the linearization table points.
142	Read Pulse Information	Read Pulse Scale and Pulse Frequency information.
143	Write Pulse Scale	Set the Pulse Scale to 1, 10, 100 or OFF.
144	Write Pulse Frequency	Set the frequency in Hz. of the pulse output burst to 1, 2, 4 or 8.
145	Pulse Output Control	Stop 1 Hz Pulse Output Test.
146	Pulse Output Test	Start 1Hz Pulse Output Test.
147	Read Alarm Info	Read Function and Level for Alarm 1 and 2.
148	Write Alarm Function	Define the function of the Alarm Output as Rate or Total.
149	Write Alarm Level	Write the value at which an alarm condition is indicated.
150	Alarm Release	Release the Alarm Output test.
151	Alarm Test	Activate Alarm Output.
152	Read Tag	Read Tag Number.
153	Write Tag	Write Tag Number. 0 to 99999999.
154	Read Sample Time	Read Sample Time.
155	Write Sample Time	Write Sample Time. Valid entries 1-80.
156	Write Password	Write 4-digit password. 9999 is max value.
157	Read Lock Status	Read Lock Status. Password is required when unit is locked.
158	Write Lock Unit	Lock the unit and enable password protection.

#	COMMAND	DESCRIPTION
159	Read Current Mode	Read mode for analog output current (4mA, 12mA, 20mA, Follows Rate).
160	Write Current Mode	Write mode for analog output current (4mA, 12mA, 20mA, Follows Rate).
161	Read Units	Read units for volume total and rate.
162	Write Flow Rate Time	Write units for flow rate time base (/Sec, /Min, /Hr, /Day).
163	Write Total Units	Write units for volume total (GAL, FT3, L, M3, BBL).

## 6.5 Device Status

The following Status Bits are implemented:

- Bit 0 - Primary Variable Out Of Limits
- Bit 1 - Non-Primary Variable Out Of Limits
- Bit 2 - Primary Variable Analog Output Saturated
- Bit 3 - Primary Variable Analog Output Fixed
- Bit 4 - More Status Available
- Bit 5 – Cold Start
- Bit 6 – Configuration Changed
- Bit 7 – Device Malfunction

### 6.6 Additional Device Status

The following Additional Device Status Bits are implemented:

Byte	Bit	Meaning
0	0	Unused
	1	Unused
	2	Pulse Output Overflow
	3	Flow Over range
	4	Flow Rate Display Too High
	5	DAC Zero Not Calibrated
	6	DAC Gain Not Calibrated
	7	Bit Current Override
1	0	Total Units Error
	1	Rate Time Units Error
	2	Linearization Function Error
	3	K-Factor Decimal Point Error
	4	Number of Points Error
	5	Total Decimal Point Error
	6	Rate Decimal Point Error
	7	Sample Time Error
2	0	Unused
	1	Unused
	2	Unused
	3	Pulse Scale Error
	4	Pulse Frequency Error
	5	Unit Locked
	6	Alarm 2 Function Error
	7	Alarm 1 Function Error

Byte	Bit	Meaning
3	0	Unused
	1	Unused
	2	Unused
	3	Unused
	4	Unused
	5	Pulse Output Test
	6	Alarm 2 Test
	7	Alarm 1 Test
4	0	Unused
	1	Unused
	2	Unused
	3	Unused
	4	Unused
	5	Unused
	6	Alarm 2 Activated
	7	Alarm 1 Activated
5	0	Unused
	1	Unused
	2	Unused
	3	Unused
	4	Unused
	5	Unused
	6	Unused
	7	Unused
6	0	Maintenance Required
	1	Device Variable Alert
	2	Critical Power Failure
	3	Unused
	4	Unused
	5	Unused
	6	Unused
	7	Unused

Byte	Bit	Meaning
7	0	Unused
	1	Unused
	2	Unused
	3	Unused
	4	Unused
	5	Unused
	6	Unused
	7	Unused
8	0	Simulation Active
	1	Non-Volatile Memory Defect
	2	Volatile Memory Defect
	3	Watchdog Reset Executed
	4	Voltage Conditions Out of Range
	5	Environment Conditions Out of
	6	Electronic Defect
	7	Unused

## 6.7 EDDL – Process Variables

### Primary Variables

- **Flow Rate** – Display of currently measured volumetric flow with units selected.
- **Flow Rate Loop Current** – Display of current value of analog output (4-20 mA) based on flow rate.
- **Flow Rate % rng** – Display of current % of flow rate range.
- **Flow Rate LRV** – Display of Lower Range Value for 4 mA flow setting.
- **Flow Rate URV** – Display of Upper Range Value for 20 mA flow setting.
- **Total** – Display of currently measured volumetric flow total with units selected.
- **Grand Total** - Display of currently measured grand total with units selected.
- **Frequency** – Display of currently measured flowmeter input frequency in Hz

### Identification

- **Tag** – Assign HART Tag to device
- **Long Tag** – Assign long HART Tag to device
- **Manufacturer** – Display HOFFER FLOW CNTRLS
- **Model** – Display HRT1
- **Dev id** – Display ID number associated with device.
- **PV Snsr s/n** – Display of serial number for Primary Variable sensor.

## 6.8 EDDL – Device Diagnostics

### Warning

- **Alarm 1 Being Tested** – Indicates Alarm Output 1 is in test mode.
- **Alarm 2 Being Tested** – Indicates Alarm Output 2 is in test mode.
- **Pulse Output Being Tested** – Indicates Pulse Output is in test mode.
- **Alarm 1 Activated** – Indicates an alarm has occurred in response to a condition assigned to Alarm 1 output.
- **Alarm 2 Activated** – Indicates an alarm has occurred in response to a condition assigned to Alarm 2 output.
- **Flow Rate Exceeds Display** - Flow rate exceeds the flow rate display capability. Displayed as **ERR** on the HRT1 LCD display. See section 5.5 Error Conditions for more information.
- **Flow Exceeds 20 mA Calibration** - Flow rate exceeds the 20 mA flow rate upper range value (URV). Analog output will saturate at 24 mA. Displayed as **FL** on the HRT1 LCD display. See section 5.5 Error Conditions for more information.
- **Pulse Rate Overflow** - Pulse output exceeds Pulse Frequency setting. Output pulses will stop during this condition. Displayed as **EPULSE** on the HRT1 LCD display. See section 5.5 Error Conditions for more information.

## 6.9 EDDL – Online

### Device Setup

- **HRT1 Tag** – Assign HRT1 serial number
- **Max Sample Time** – Assign the maximum time in tenths of a second to sample the input frequency. This setting determines the amount of time the HRT1 will wait for the next input pulse before returning to 0. Valid entry is 1-80, with 80 = 8 seconds. Default is 1. Changing this setting is only recommended for low flow applications below 1 Hz. See section 4.1 Local Configuration for more information.

- **Change Lock Status** – Enable password protection by selecting YES, disable by selecting NO.
- **Password** – Assign a 4-digit password.

### Flow Setup

- **Rate Units** – Select SECONDS, MINUTES, HOURS or DAYS for flow rate units.
- **Lower Flow Rate for 4 mA output (LRV)** – Assign flow rate for 4 mA output.
- **Upper Flow Rate for 20 mA output (URV)** – Assign flow rate for 20 mA output.
- **Rate Decimal Point** – Select displayed flow rate resolution as 00000, 0000.0, 000.00 or 00.000.

### Total Setup

- **Clear Total** – Select YES to clear Total (Grand Total is non-resettable)
- **Set Total** – Write a specific value to Total.
- **Units** – Select L, M3, GAL, BBL, FT3 OR “BLANK”(custom) for Total units.
- **Total Decimal Point** – Select displayed total resolution as 00000000, 0000000.0, 000000.00 or 00000.000.

### Outputs Setup

#### Pulse Output

- **Pulse Scale** – Select OFF, 1, 10 or 100. Pulses are scaled according to the least significant digit of the displayed total. For example, if Total Decimal places is set to 0000000.0, and Pulse Scale is 1, then 1 pulse is output for each tenth (0.1) of a unit. Changing the Pulse Scale to 10 would output one (1) pulse for every 1.0 unit of volume. OFF turns Pulse Output off.

- **Pulse Frequency** – Select 1, 2, 4 or 8 to select the frequency in Hz. of the pulse output burst.
- **Pulse Test** – Outputs a test frequency of 1 Hz / 50% duty cycle on the pulse output terminals.

#### Analog Setup

- **Current Mode** – Select FOLLOWS RATE or SET TO 4 mA, 12 mA, or 20 mA.
- **D/A trim** – Calibrate the analog output 4 mA and 20 mA reading with a reference meter connected.
- **Loop Test** – Set analog output to fixed mode by selecting 4 mA, 20 mA or OTHER.

#### Alarm 1

- **Alarm 1 Function** – Select TOTAL, RATE or OFF.
- **Alarm 1 Out** – Numeric entry to assign an alarm threshold.
- **Set Alarm 1 ON** – Toggle Alarm 1 Output to test.

#### Alarm 2

- **Alarm 2 Function** – Select TOTAL, RATE or OFF.
- **Alarm 2 Out** – Numeric entry to assign an alarm threshold.
- **Set Alarm 2 ON** – Toggle Alarm 2 Output to test.

#### Meter Setup

- **Linearization** – Select AVERAGE K-FACTOR to use a single K-Factor or LINEARIZATION TABLE to enter up to 20 points.
- **K-Factor Decimal Point Location** - Select k-factor resolution as 00000000, 0000000.0, 000000.00 or 00000.000

- **Number of Points in Table** – Select the number of points (1-20) in the table when LINEARIZATION TABLE is selected.
- **Frequency/K-Factor** – Enter Frequency and K-Factors for each point in table.
- **Average K-Factor** – Enter Average K-Factor when AVERAGE K-FACTOR is selected for Linearization.
- **Correction Factor** – User defined flow total multiplier between 0.001 and 99999.999.

HART Setup

- **Poll Addr** – (Polling address) Assign a number between 0-15 to be used in multidrop applications.
- **Date** – Enter the Date
- **Descriptor** – Enter a descriptor
- **Message** – Enter a message
- **Final assembly num** – Enter Assembly number.

This Page Intentionally Left Blank

## Appendix A – Default Configuration

Factory default configuration:

<i>FIELD</i>	<i>Value</i>
TAG	10000000
LINEARIZATION METHOD	Average
K-FACTOR DECIMAL LOCATION	3
AVERAGE K-FACTOR	1.00
NUMBER OF POINTS	20
FREQUENCY 01	4999.981
FREQUENCY 02	4999.982
FREQUENCY 03	4999.983
FREQUENCY 04	4999.984
FREQUENCY 05	4999.985
FREQUENCY 06	4999.986
FREQUENCY 07	4999.987
FREQUENCY 08	4999.988
FREQUENCY 09	4999.989
FREQUENCY 10	4999.990
FREQUENCY 11	4999.991
FREQUENCY 12	4999.992
FREQUENCY 13	4999.993
FREQUENCY 14	4999.994
FREQUENCY 15	4999.995
FREQUENCY 16	4999.996
FREQUENCY 17	4999.997
FREQUENCY 18	4999.998
FREQUENCY 19	4999.999
FREQUENCY 20	5000.000
K-FACTOR 01	1.00
K-FACTOR 02	1.00
K-FACTOR 03	1.00
K-FACTOR 04	1.00
K-FACTOR 05	1.00
K-FACTOR 06	1.00
K-FACTOR 07	1.00
K-FACTOR 08	1.00
K-FACTOR 09	1.00
K-FACTOR 10	1.00
K-FACTOR 11	1.00
K-FACTOR 12	1.00

Appendix A – Default Communications 40

K-FACTOR 13	1.00
K-FACTOR 14	1.00
K-FACTOR 15	1.00
K-FACTOR 16	1.00
K-FACTOR 17	1.00
K-FACTOR 18	1.00
K-FACTOR 19	1.00
K-FACTOR 20	1.00
CORRECTION FACTOR	1.000
TOTAL UNITS	100 ( <i>GAL</i> )
RATE UNITS	MINUTES
MAX SAMPLE TIME	01
OUT LOW (LRV-4MA)	00000.000
OUT HIGH (URV-20 MA)	99.999
PULSE SCALE	0 ( <i>OFF</i> )
PULSE FREQUENCY	8
ALARM 1 FUNCTION	Off
ALARM 1 SETPOINT	99999.981
ALARM 2 FUNCTION	Off
ALARM 2 SETPOINT	99999.981
CURRENT OUT	FOLLOWS RATE
PULSE TEST	No
ALARM 1 TEST	No
ALARM 2 TEST	No