

# *Nova Flow*

## *Modular Flow Computer*

### *Plug-n-Flow Architecture*

## *USER'S MANUAL*



HP-302  
May 2011

**H** **HOFFER FLOW CONTROLS, INC.**  
PERFECTING MEASUREMENT™

107 Kitty Hawk Lane • P.O. Box 2145 • Elizabeth City, NC 27906-2145  
1-800-4584 • 252-331-1997 • FAX: 252-331-2886  
[www.hofferflow.com](http://www.hofferflow.com) • E-mail: [info@hofferflow.com](mailto:info@hofferflow.com)



---

## Notice

HOFFER FLOW CONTROLS, INC. MAKES NO WARRANTY OF ANY KIND WITH REGARD TO THIS MATERIAL, INCLUDING, BUT NOT LIMITED TO, THE IMPLIED WARRANTIES OF MERCHANTABILITY AND FITNESS FOR A PARTICULAR PURPOSE.

This manual has been provided as an aid in installing, connecting, calibrating, operating, and servicing this unit. Every precaution for accuracy has been taken in the preparation of this manual; however, HOFFER FLOW CONTROLS, INC. neither assumes responsibility for any omissions or errors that may appear nor assumes liability for any damages that may result from the use of the products in accordance with information contained in the manual.

HOFFER FLOW CONTROLS' policy is to provide a user manual for each item supplied. Therefore, all applicable user manuals should be examined before attempting to install or otherwise connect a number of related subsystems.

During installation, care must be taken to select the correct interconnecting wiring drawing. The choice of an incorrect connection drawing may result in damage to the system and/or one of the components.

Please review the complete model number of each item to be connected and locate the appropriate manual(s) and/or drawing(s). Identify all model numbers exactly before making any connections. A number of options and accessories may be added to the main instrument, which are not shown on the basic user wiring. Consult the appropriate option or accessory user manual before connecting it to the system. In many cases, a system wiring drawing is available and may be requested from HOFFER FLOW CONTROLS.

This document contains proprietary information, which is protected by copyright. All rights are reserved. No part of this document may be photocopied, reproduced, or translated to another language without the prior written consent of HOFFER FLOW CONTROLS, INC.

HOFFER FLOW CONTROLS' policy is to make running changes, not model changes, whenever an improvement is possible. This affords our customers the latest in technology and engineering. The information contained in this document is subject to change without notice.

---

## RETURN REQUESTS / INQUIRIES

---

Direct all warranty and repair requests/inquiries to the Hoffer Flow Controls Customer Service Department, telephone number (252) 331-1997 or 1-800-628-4584. BEFORE RETURNING ANY PRODUCT(S) TO HOFFER FLOW CONTROLS, PURCHASER MUST OBTAIN A RETURNED MATERIAL AUTHORIZATION (RMA) NUMBER FROM HOFFER FLOW CONTROLS' CUSTOMER SERVICE DEPARTMENT (IN ORDER TO AVOID PROCESSING DELAYS). The assigned RMA number should then be marked on the outside of the return package and on any correspondence.

FOR **WARRANTY** RETURNS, please have the following information available BEFORE contacting HOFFER FLOW CONTROLS:

1. P.O. number under which the product was PURCHASED,
2. Model and serial number of the product under warranty, and
3. Repair instructions and/or specific problems relative to the product.

FOR **NON-WARRANTY** REPAIRS OR **CALIBRATIONS**, consult HOFFER FLOW CONTROLS for current repair/calibration charges. Have the following information available BEFORE contacting HOFFER FLOW CONTROLS:

1. P.O. number to cover the COST of the repair/calibration,
2. Model and serial number of the product, and
3. Repair instructions and/or specific problems relative to the product.

---

## LIMITED WARRANTY

---

HOFFER FLOW CONTROLS, INC. ("HFC") warrants HFC's products ("goods") described in the specifications incorporated in this manual to be free from defects in material and workmanship under normal use and service, but only if such goods have been properly selected for the service intended, properly installed and properly operated and maintained. This warranty shall extend for a period of one (1) year from the date of delivery to the original purchaser (or eighteen (18) months if the delivery to the original purchaser occurred outside the continental United States). This warranty is extended only to the original purchaser ("Purchaser"). *Purchaser's sole and exclusive remedy is the repair and/or replacement of nonconforming goods as provided in the following paragraphs.*

In the event Purchaser believes the goods are defective, the goods must be returned to HFC, transportation prepaid by Purchaser, within twelve (12) months after delivery of goods (or eighteen (18) months for goods delivered outside the continental United States) for inspection by HFC. If HFC's inspection determines that the workmanship or materials are defective, the goods will be either repaired or replaced, at HFC's sole determination, free of additional charge, and the goods will be returned, transportation paid by HFC, using the lowest cost transportation available.

Prior to returning the goods to HFC, Purchaser must obtain a Returned Material Authorization (RMA) Number from HFC's Customer Service Department within 30 days after discovery of a purported breach of warranty, but no later than the warranty period; otherwise, such claims shall be deemed waived. See the Return Requests/Inquiries Section of this manual.

If HFC's inspection reveals the goods are free of defects in material and workmanship or such inspection reveals the goods were improperly used, improperly installed, and/or improperly selected for service intended, HFC will notify the purchaser in writing and will deliver the goods back to Purchaser upon (i) receipt of Purchaser's written instructions and (ii) the cost of transportation. If Purchaser does not respond within thirty (30) days after notice from HFC, the goods will be disposed of in HFC's discretion.

HFC does not warrant these goods to meet the requirements of any safety code of any state, municipality, or other jurisdiction, and Purchaser assumes all risk and liability whatsoever resulting from the use thereof, whether used singly or in combination with other machines or apparatus.

This warranty shall not apply to any HFC goods or parts thereof, which have been repaired outside HFC's factory or altered in any way, or have been subject to misuse, negligence, or accident, or have not been operated in accordance with HFC's printed instructions or have been operated under conditions more severe than, or otherwise exceeding, those set forth in the specifications for such goods.

**THIS WARRANTY IS EXPRESSLY IN LIEU OF ALL OTHER WARRANTIES, EXPRESSED OR IMPLIED, INCLUDING ANY IMPLIED WARRANTY OF MERCHANTABILITY OR FITNESS FOR A PARTICULAR PURPOSE. HFC SHALL NOT BE LIABLE FOR ANY LOSS OR DAMAGE RESULTING, DIRECTLY OR INDIRECTLY, FROM THE USE OR LOSS OF USE OF THE GOODS. WITHOUT LIMITING THE GENERALITY OF THE FOREGOING, THIS EXCLUSION FROM LIABILITY EMBRACES THE PURCHASER'S EXPENSES FOR DOWNTIME OR FOR MAKING UP DOWNTIME, DAMAGES FOR WHICH THE PURCHASER MAY BE LIABLE TO OTHER PERSONS, DAMAGES TO PROPERTY, AND INJURY TO OR DEATH OF ANY PERSONS. HFC NEITHER ASSUMES NOR AUTHORIZES ANY PERSON TO ASSUME FOR IT ANY OTHER LIABILITY IN CONNECTION WITH THE SALE OR USE OF HFC'S GOODS, AND THERE ARE NO ORAL AGREEMENTS OR WARRANTIES COLLATERAL TO OR AFFECTING THE AGREEMENT. *PURCHASER'S SOLE AND EXCLUSIVE REMEDY IS THE REPAIR AND/OR REPLACEMENT OF NONCONFORMING GOODS AS PROVIDED IN THE PROCEEDING PARAGRAPHS. HFC SHALL NOT BE LIABLE FOR ANY OTHER DAMAGES WHATSOEVER INCLUDING INDIRECT, INCIDENTAL, OR CONSEQUENTIAL DAMAGES.***

---

## Disclaimer

Specifications are subject to change without notice.  
Some pages are left intentionally blank.

# Contents

---

<b>Contents</b> .....	i
<b>Specifications</b> .....	1
General Specifications.....	1
Hardware Specification.....	2
<b>Architecture</b> .....	5
Multiple Flow Channels.....	5
Front Panel.....	5
Rear Panel.....	6
Optional Modules.....	7
<b>Model Number &amp; Hardware Code</b> .....	9
Hardware Code.....	10
<b>Operation</b> .....	11
Displaying Process Parameters.....	11
Displaying Date and Time.....	12
Displaying Base Conditions.....	12
Displaying Software Version and Electronic ID.....	13
Clearing.....	13
Printing.....	13
Error Messages.....	13
Passwords.....	13
Diagnostics.....	14
Programming.....	14
Selecting a Menu Item.....	14
Reviewing Settings.....	14
Editing Program Settings.....	15
<b>Menu Structure</b> .....	17
1. CLEAR Menu.....	21
2. PRINT Menu.....	21
3. PROGRAM Menu.....	22
3.1. I/O Configuration.....	23
3.2. System Configuration.....	28
3.3. Channel Configuration.....	30
3.4. Meter Configuration.....	31
3.5. Slot Configuration.....	32
4. DIAGNOSTICS Menu.....	33
Main Board Digital I/O.....	33
Dual Relay Mode.....	33
Dual Pulse Output Module.....	34
Analog Output Mode.....	33
RTD/ Analog Input Module.....	35
5. BASE CONDITIONS.....	36
<b>Communications</b> .....	37
<b>Installation</b> .....	39
Notes.....	39
Main Connector.....	39
Power Supply Connections.....	40
Pickup Coil Connections.....	41
I/O1 - I/O7 Connections.....	42
I/O8.....	43
Flow B Module Connections.....	45
RTD/Analog Input Module.....	46
Analog Output Module.....	47

Dual Pulse Output Module .....	48
Dual Relay Module.....	48
Communications .....	49
<b>Hardware Configuration .....</b>	<b>51</b>
I/O Configuration .....	51
Flow Input Selection.....	52
Dual Coil Pulse Security.....	53
Digital I/O 1-7 .....	53
Digital I/O8.....	54
RTD/Analog Input Module.....	55
Analog Output Module.....	56
Pulse Output Module .....	56
<b>Windows Configuration .....</b>	<b>57</b>
Installation .....	57
Startup.....	57
Print .....	58
Z-Table .....	58
Configuration.....	59
I/O Configuration Menu .....	59
Meter Configuration Menu.....	60
Channel Configuration Menu .....	61
System Configuration Menu.....	62
Print Menu .....	63
Downloading the Configuration .....	64
Configuration Files .....	64
Saving Configuration Files.....	64
Opening Configuration Files .....	64
<b>Appendix A: Liquid Calculation Flow Chart.....</b>	<b>65</b>
<b>Appendix B: Gas Calculation Flow Chart.....</b>	<b>66</b>
<b>Appendix C: Units of Measure .....</b>	<b>67</b>
<b>Appendix D: Error Messages .....</b>	<b>70</b>

# Specifications

---

## General Specifications

### Environmental

Operating Temperature: -20°C to 70°C  
Storage Temperature: -40°C to 85°C  
Humidity: 0-95% Non-condensing

### Approvals and Regulatory Compliance

CE

#### Standards:

AGA 8/API 14.2  
AGA 7  
OIML Tc 8 Sc 7, R117, R118  
ISO 6551, 7637  
NIST Handbook 44, 3.37

### Enclosure

1/2 DIN panel mount, aluminum housing  
Optional Ex proof, NEMA 4X

### Power Supply

10 to 30 Volts DC, 2A max  
85-265 VAC, 50/60Hz, 400mA max

### Display

128x64 graphical display displays 4 parameters simultaneously  
Easy scroll through matrix of 48 parameters  
LED back light  
Adjustable contrast

### Keypad

3 soft keys  
14 assigned keys  
Embossed overlay  
Stainless steel membrane switches

### IR Interface (Optional)

Front panel infrared transmitter/receiver for remote operation and communication

### Diagnostics

Multiple error messages  
Failure detection for RTD and all analog inputs  
System configuration and diagnostics from a PC computer through RS-232 port

### Field Expandable Hardware and Software

Easy to add and replace modules  
Software configuration based on installed modules

## Specifications

### Alarms

Multiple visual/audio alarms  
HI/LO, HI/HI, LO/LO

### Batch Controller

Single/Dual Stage batch operations  
Count UP/DOWN  
Remote batching capability

### Energy Calculator

Cooling, Heating, Heat/Cool Auto Switch

### Flow Compensation and Calculation Methods

20-point flow linearization  
FWD/REV tables for two channels  
Mass and Volumetric calculations available for fluids and gases  
Up to 4 fluid properties tables  
Compressibility table for gases

### Security Features

Audit Trail with Time/Date/ID stamping for configuration changes

## Hardware Specification

Nova Flow construction allows full flexibility in selecting flow computer functions. The base Nova-Flow unit provides one flow meter input, and 8 digital I/O lines. Each I/O line can be configured as Input or Output. The unit has 8 expansion slots for optional I/O modules. Almost any combination of modules can be selected to meet the customer's individual needs.

### BASE UNIT

#### Flow Meter Input

Selectable: Magnetic coil, MCP coil, TTL, Open Collector, Dry Contact  
Frequency range: 0.2 to 5,000 Hz.  
Amplitude: 10mVrms to 30Vrms

#### Digital I/O

7 digital lines selectable for Input or Output  
One optically isolated Digital Output  
Software configurable function: pulse output, remote clear, batch start/stop, batch control, alarms.  
Selectable voltage level: 0-5V, 0-10V, or Open Collector rated at 30Vdc, 250mA max.

Auxiliary 24 Vdc power supply @ max 100mA

## OPTIONAL MODULES

### Dual RTD and Dual Analog Input Module

- Includes two RTDs and two analog inputs
- Compatible with 100, 1000, and 2500 Ohm RTD probes
- Analog inputs configurable for temperature, pressure, density, specific gravity, or flow
- Accuracy 0.025%
- Resolution 12 bit
- Range 4-20mA, or 1-5V
- Over voltage and over current protected

### Analog Output Module

- 12 bit true D/A
- Selectable 4-20mA, 1-5V
- Current sourcing, or powered from external power supply

### Dual Relay Module

- Includes two SPDT relays
- Dry Contact or Solid State Relays
- Dry Contact:  $V_{max}$  125Vac,  $I_{max}$  10A /  $V_{max}$  250 V ac,  $I_{max}$  5A
- Solid State:  $V_{max}$  switching 175Vdc,  $I_{max}$  switching 250mA,  $I_{max}$  carry 1.5A
- Software configurable for flow, temperature, pressure, and density alarms (high and low)

### RS232 Port Module

- Includes one RS232 serial port, screw terminal or DB9 connector
- Printing, configuration, MODBUS interface

### RS485 Port Module

- Includes one RS485 serial port, screw terminal connector
- Printing, configuration, MODBUS interface

### Dual Pulse Out Module

- Scaled pulse per unit of measure
- Voltage level: 0-5V, 0-12V, Open Collector 30Vdc, 250mA max.

### Flow B Module (second flow input)

- Magnetic coil, MCP coil, TTL/CMOS, Open Collector, Dry Contact
- Quadrature input for magnetic coil, ISO6551 level B compliant
- Frequency range 0.2 to 5,000 Hz
- Amplitude 10mVrms to 30Vrms

**THIS PAGE LEFT INTENTIONALLY BLANK**

# Architecture

---

Nova-Flow architecture allows for many combinations of software and hardware options. The modular design can accommodate a variety of flow applications. The Nova-Flow chassis has 8 expansion slots accessible through the rear panel to install optional “plug-in” modules. There are several modules for various input output signals, and communication requirements. In addition there are several software options for specific applications such as batching, manifold configuration and energy calculation.

## Multiple Flow Channels

Nova-Flow can monitor up to four flow channels. The flow channels are identified with letters A, B, C, D. Channels A and B are frequency inputs and can work with a turbine meter or any other frequency producing flow meter. Channels C and D are analog inputs and can accept 4-20 mA or 1-5 volt signals. Any two of the four channels can be fully compensated for temperature and pressure with an appropriate selection of the optional modules.

## Front Panel

Nova-Flow has a graphical display with 64x128 pixel resolution. It displays five lines of text: four lines are used for process parameters, and the fifth line at the bottom of the display is used for software-controlled key labels. There are three software-controlled keys (soft-keys) located under the display, two scroll keys on the right side of the display, and a numerical keypad. Soft-key functions vary with the operating mode of the unit. The soft-key labels are displayed above the keys and they change according to the keys function. Two scroll keys (UP and DOWN) are used to select display parameters, and to navigate in the program menu. The numerical keypad is used to enter numerical values, or to select items in the menu. Under the scroll keys there is an infrared window for communication with computers equipped with IR interface.

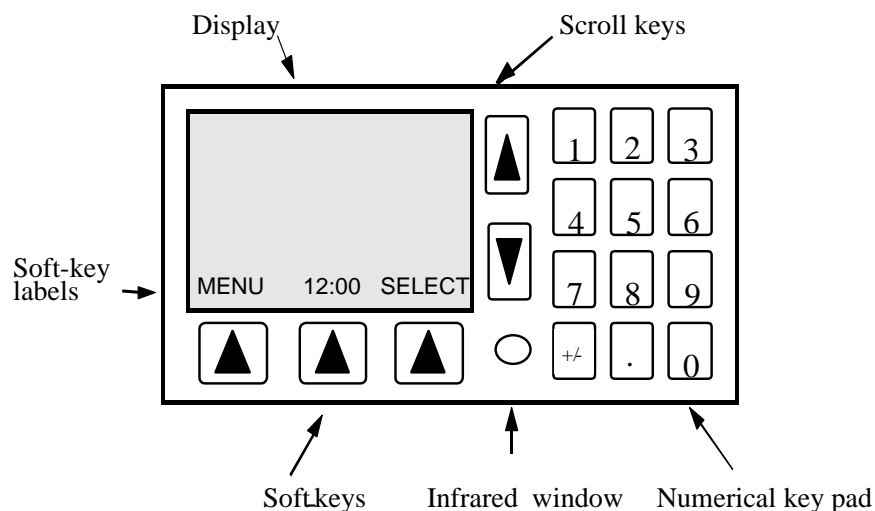

Rear Panel

The main board 18 Pin connector provides connection for all standard circuits: the flow meter input, auxiliary 24 Vdc output, and 8 digital I/O lines configurable for either input or output.

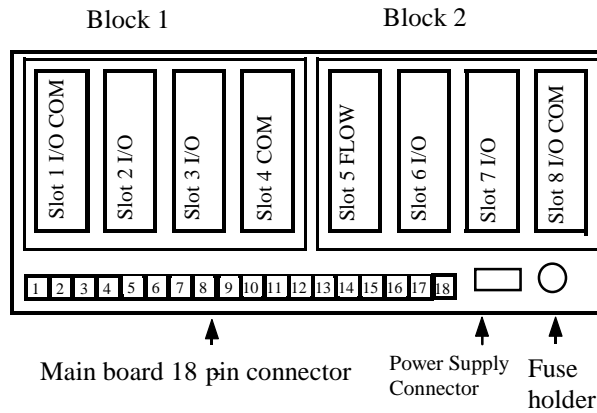

There are 8 optional module slots grouped in two blocks: Block 1 and Block 2. Each block consists of four slots. Each slot has a specific functionality that has to be matched with the module type. Slot #5 is for flow meter module only, slot #4 is for communication modules only. Slots 2,3,6,7 are for input/output modules only, slots 1,8 are for use with input/output and communication modules.

Slot 1	Input/output modules and Communication modules
Slot 2	Input/output modules
Slot 3	Input/output modules
Slot 4	Communication modules
Slot 5	Flow meter module
Slot 6	Input/output modules
Slot 7	Input/output modules
Slot 8	Input/output modules and Communication modules

Slot/Module Compatibility Table.

## Optional Modules

There are three types of optional modules: input/output (I/O), communication (COM), and flow meter modules. When installing a module, the type of module has to be matched with the type of slot in the Nova-Flow chassis.

The following modules are available:

### I/O Modules:

RTD/Analog Input  
Analog output  
Dual relay  
Pulse out

### Com Modules:

RS232  
RS485

### Flow Meter Module:

Flow B

A combination of the above modules results in over 50,000 different configurations available for Nova-Flow.

### Optional Modules

<i>Module Name</i>	<i>Function</i>	<i>Available slot</i>	<i>Code #</i>
RTD/ANALOG IN	Dual RTD 2 or 3 wire, and dual analog input 4-20mA, or 1-5V	1, 2, 3, 6, 7, 8	T1-T16*
ANALOG OUT	Analog output 4-20mA, or 1-5V	1, 2, 3, 6, 7, 8	A7, A8*
RELAY	Dual SPST relay	1, 2, 3, 6, 7, 8	R1, R2*
PULSE OUT	Pulse output for frequency above 1Hz	1, 2, 3, 6, 7, 8	P
RS232	Serial communication, terminal block	1, 4, 8	S2
RS232-DB9	Serial communication, DB9 connector	1, 4	S9
RS485	Serial communication, terminal block	1, 4, 8	S4
FLOW B	Flow meter input with pulse security	5	BM, BRF

\*See model number designation section

### Notes!

1. When a module is installed, removed, or moved to a different slot, the software configuration has to be changed accordingly. Refer to section "Slot configuration".
2. Hoffer recommends that Slot 1 is always equipped with a serial communication module to allow configuration changes from a PC computer.

**THIS PAGE LEFT INTENTIONALLY BLANK**

# Model Number & Hardware Code

## Nova Flow Model Number:

**NF-A7-S2-MB-1-M-T1-1-H/L R1-P-F-BP-SP**

### Analog Outputs

- (A7) 4-20mA
- (A8) 1-5Vdc

### Communication Ports

- (S2) RS232/ Screw Terminal
- (S4) RS485/ Screw Terminal
- (S9) RS-232-S9

### Scaled Output Pulses

- (MB) Mother board
- (P) Dual High Speed Output

### Number of Channels

- (1) Single Channel
- (B) Dual Channel, Bi- directional
- (PSB) Pulse Security
- (B3) 3 Channel Unit
- (B4) 4 Channel

### Flowmeter Input

- (M) Magnetic Coil
- (MC3PA) RF Coil
- (RPR) Redi-pulse RF coil
- (RPM) Redi-pulse Magnetic Coil
- (DMX) Redi-pulse I.S. Magnetic Coil
- (DRX) Redi-pulse I.S. RF Coil

### Temperature/Pressure Compensation, Analog and RTD Inputs

- (T1) Two 4-20mA, two 100 ohm RTD inputs
- (T2) Two 1-5Vdc, two 100 ohm RTD inputs
- (T3) One 4-20mA, one 1-5Vdc, two 100 RTD inputs
- (T4) Two 4-20mA, two 1000 ohm RTD inputs
- (T5) Two 1-5Vdc, two 1000 ohm RTD inputs
- (T6) One 4-20mA, one 1-5Vdc, two 1000 ohm RTD inputs
- (Z) Add (Z) Compressability software after all options above for gas

### Special Features

- (SP) Any special features that are not covered in the model number

### Backplane

- (B) Second backplane, required if slots 6, 7, or 8 have been configured
- (BPB) Use option if (B) dual channel has been equipped in slot 5

### Accessories/Options

- (F) Flowmeter mounted for (ND)
- (H) Heater for (ND) & E options only

### Enclosure Style

- (P) Panel Mount
- (ND) Mounted on door with keypad accessible
- (E) Explosion Proof, Visible thru window
- (C) Portable

### Alarms

- (H/L R1) ½ amp dual SPDT, high speed 200 Hz max
- (H/L R2) Dual SPDT., 10 amp relays

### Power Input

- (1) 115 Vac 50/60 Hz
- (2) 220 Vac 50/60 Hz
- (\*) 10-30Vdc

**Hardware Code**

In addition to the model number Nova Flow units are labeled with a hardware code to help the factory identify installed hardware options. The hardware code consists of a string of up to 8 symbols representing modules in the order they are installed in the chassis. Each symbol stands for one module. An “X” indicates there is no module installed in the corresponding slot. The first four symbols represent modules installed in the Block-1, the second four symbols represent modules installed in the Block -2. The second four symbols are deleted if there are no modules in the Block-2 slots. This also indicates that the Block-2 board is not installed.

Hardware code example:

S2-T1-A7-S4--BM-R1-P-X

Slot 1	Slot 2	Slot 3	Slot 4	Slot 5	Slot 6	Slot 7	Slot 8
RS232	RTD/ Analog Input	Analog Output	RS485	Flow B	Dual Relay	Pulse Out	None

**Module Code Table**

<i>Module Name</i>	<i>Description</i>	<i>Type</i>	<i>Code</i>	<i>Max # of Modules</i>
Flow B	Flow meter input with pulse security, Mag or pulse coil	Flow	BM	1
Flow B	Flow meter input with pulse security, RF coil	Flow	BRF	1
RS 232	Serial communication, screw terminal.	Com	S2	3
RS 232-DB9	Serial communication, DB9 connector.	Com	S9	2
RS 485	Serial communication, screw terminal.	Com	S4	3
RTD/Analog In - 1	2x 100Ω RTD, 2x 4-20 mA	I/O	T1	2*
RTD/Analog In - 2	2x 100Ω RTD, 2x 1-5 V	I/O	T2	2*
RTD/Analog In - 3	2x 100Ω RTD, 1-5 V, 4-20mA	I/O	T3	2*
RTD/Analog In - 4	2x 1000Ω RTD, 2x 4-20 mA	I/O	T4	2*
RTD/Analog In - 5	2x 1000Ω RTD, 2x 1-5 V	I/O	T5	2*
RTD/Analog In - 6	2x 1000Ω RTD, 1-5 V, 4-20mA	I/O	T6	2*
Analog Output	4-20mA	I/O	A7	2*
Analog Output	1-5V	I/O	A8	2*
Dual Relay -1	2x SPST solid state	I/O	R1	3*
Dual Relay -2	2x SPST 10A, 250 VAC	I/O	R2	3*
Pulse out	2x pulse output (<200Hz)	I/O	P	1*

\*Recommended for typical applications/consult factory.

Com = communication module, I/O = input/output module, Flow = frequency input module

# Operation

---

This section applies only to units that have already been programmed. For initial programming and set up refer to the Menu Structure section.

## Displaying Process Parameters

Nova-Flow displays simultaneously four process parameters. To set a desired parameter on one of the four display lines press SELECT key until the line is highlighted, press CHAN key to choose a flow channel (on multi-channel systems), and then scroll through the parameters using SCROLL keys until the desired parameter is displayed.

When one of the lines is selected, the center soft-key label changes from DATE/TIME to CHAN on multi channel system.

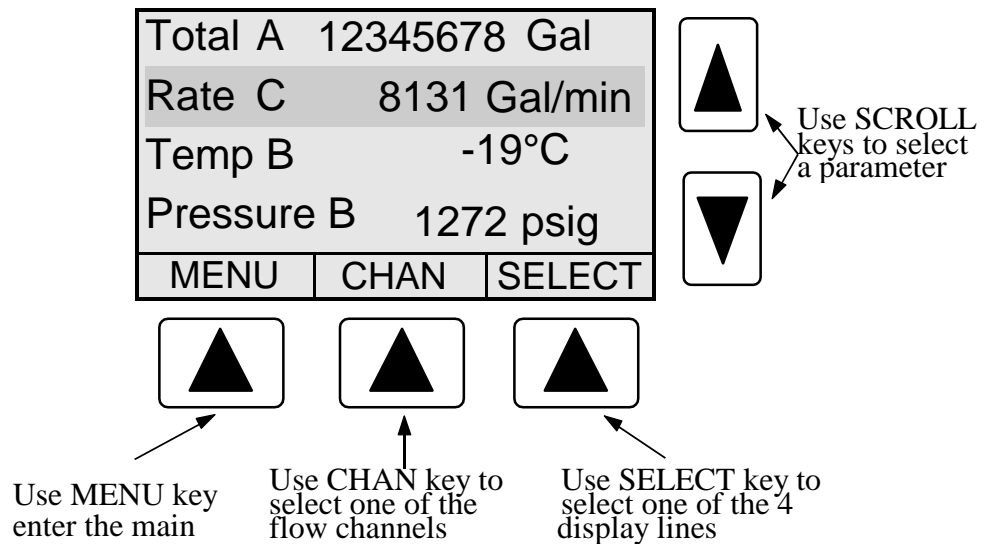

The following process parameters are utilized for the display

<i>Parameter name</i>	<i>Displayed name</i>	<i>Description</i>
Uncorrected Total	U/Total	Volumetric total at flowing conditions, calculated based on turbine calibration data (K-factor) stored in the Nova-Flow
Total	Total	Corrected total, compensated to a selected reference conditions, expressed in units of volume or mass, depending on calculation and compensation method.
Accumulated Total	AccTot	Accumulated corrected total
Uncorrected Rate	U/Rate	Volumetric flow rate at flowing conditions, calculated based on turbine calibration data (K-factor) stored in the Nova-Flow
Flow Rate	Rate	Corrected rate, compensated to a selected reference conditions, expressed in units of volume or mass, depending on calculation and compensation method.
Temperature	Temp	Actual flowing temperature. A programmed default temperature is displayed whenever the default temperature is being used for calculation, or “N/A” when temperature is not selected for compensation.
Pressure	Press	Actual flowing pressure. A programmed default pressure is displayed whenever the default pressure is being used for calculation, or “N/A” when pressure is not selected for compensation.
Density	Density	Actual flowing density. A programmed default density is displayed whenever the default density is being used for calculation, or “N/A” when density is not selected for compensation.

On multi-channel system parameters are displayed with extensions Ch A, Ch B, Ch C, or Ch D to identify the flow channel they are associated with.

### Displaying Date and Time

Time or date is displayed in the center soft-key field, when this field is not being used.



When time or date is displayed use the center soft-key to switch between the time and date.

### Displaying Base Conditions

Currently configured Base Operating Conditions may be displayed by pressing the +/- key on the numerical keypad.

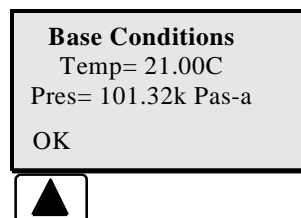

## Displaying Software Version and Electronic ID

The software version and unique electronic identification number may be displayed by pressing the decimal key on the numeric keypad.

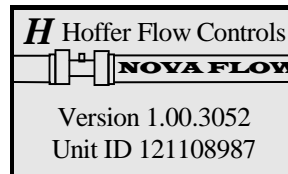

## Clearing

To access the clearing menu press MENU key, and select CLEAR using ARROW keys or the numerical keypad. Select an item from the menu and press the CLEAR key. A message “Are you sure” will be displayed. Press YES key if you still want to clear a register. After pressing the YES key to confirm, information stored in the register will be lost.

Clearing is not available while flow is present. A warning message will be displayed when CLEAR key is pressed while flow is present.

## Printing

To access the printing menu press MENU key, and select PRINT using SCROLL keys or the numerical keypad. Select a desired item for printing and press PRINT key. The printing function is available while flow is present.

*Example:*

To print configuration data press MENU, select PRINT, CONFIGURATION, and press PRINT key.

## Error Messages

There are a number of warnings and error messages that guide the user if there is an operational problem or conflict in the configuration parameters. When an error occurs the center soft-key label switches to “Errors”. Press the ERRORS key to view and acknowledge errors. If there is more than one error message, press the key again until all messages are cleared. Refer to appendix D for the error messages list.

## Passwords

The Nova-Flow unit has a two level password protection: operator and supervisor. At each level there are five user ID numbers available. Any configuration parameter that may affect the flow calculation is protected with the supervisor password. The unit is shipped unprotected, with all passwords set at 0000.

### Diagnostics

To enter the diagnostic mode press MENU key, and select DIAGNOSTICS.

### Programming

The Nova-Flow unit is shipped from the factory fully programmed per user specification. However, it is recommended to verify the program settings before the unit is installed. Programming may be performed from the Nova-Flow front panel, or from a personal computer using Hoffer configuration software. Connection to the personal computer can be established either through the RS232 cable, or the infrared interface.

The program menu may not be entered while flow is present. This prevents parameters affecting flow calculations to be changed during a process.

To enter the program mode press MENU key, and select PROGRAM.

### Selecting a Menu Item

The Nova-Flow program menu is a multi-layer matrix of submenus. Refer to the menu chart in the Menu Structure section for help navigating through the menu structure and locating a desired menu item.

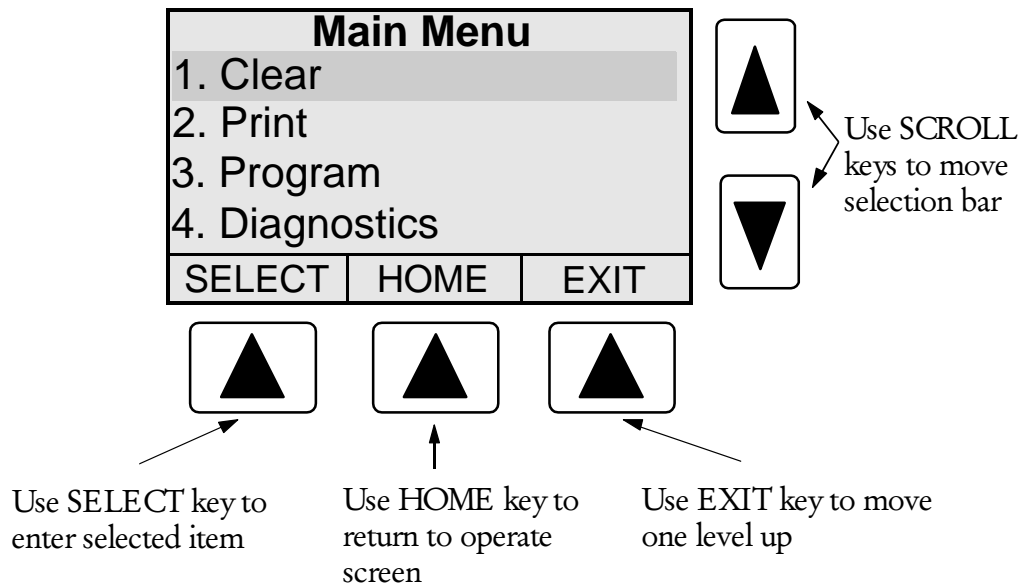

### Reviewing Settings

Program settings are displayed at the lowest level in the program menu. Once a menu item is selected, it can be changed using the EDIT key.

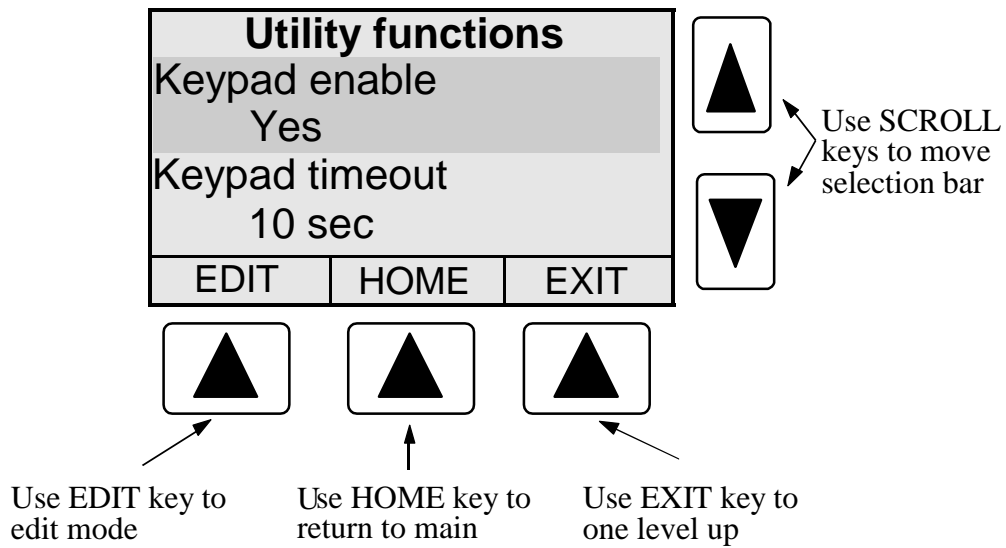

### Editing Program Settings

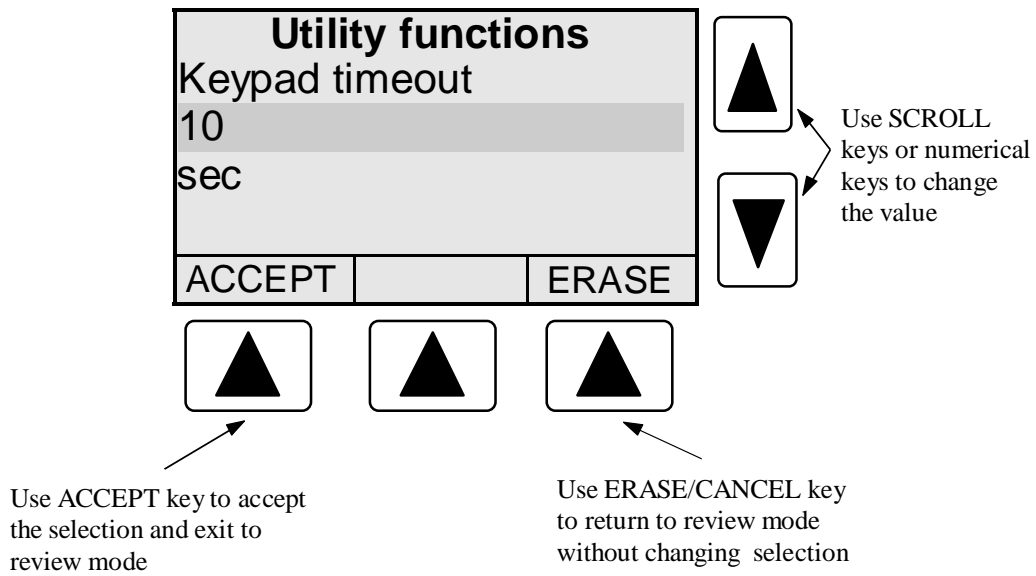

**THIS PAGE LEFT INTENTIONALLY BLANK**

# Menu Structure

---

The structure of the program menus varies depending on the type and number of optional modules installed in the Nova-Flow. Not all of the menu items described in this manual may be available on Nova Flow.

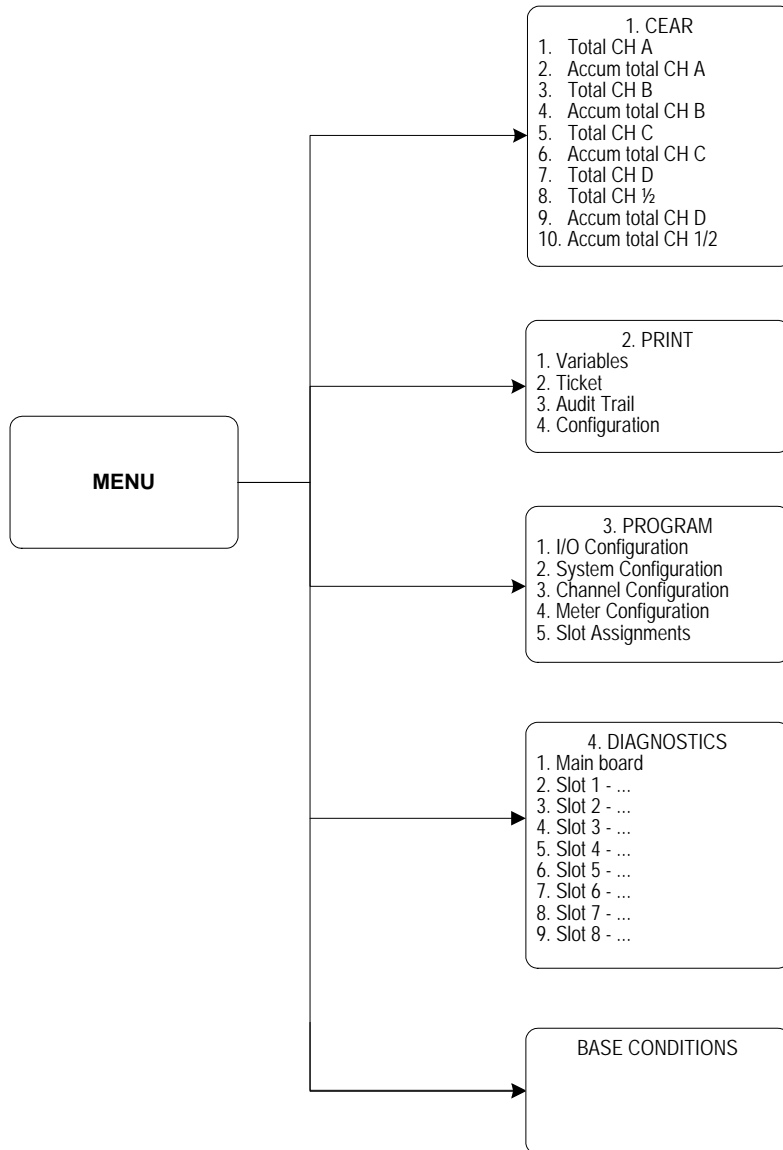

## Program Menu

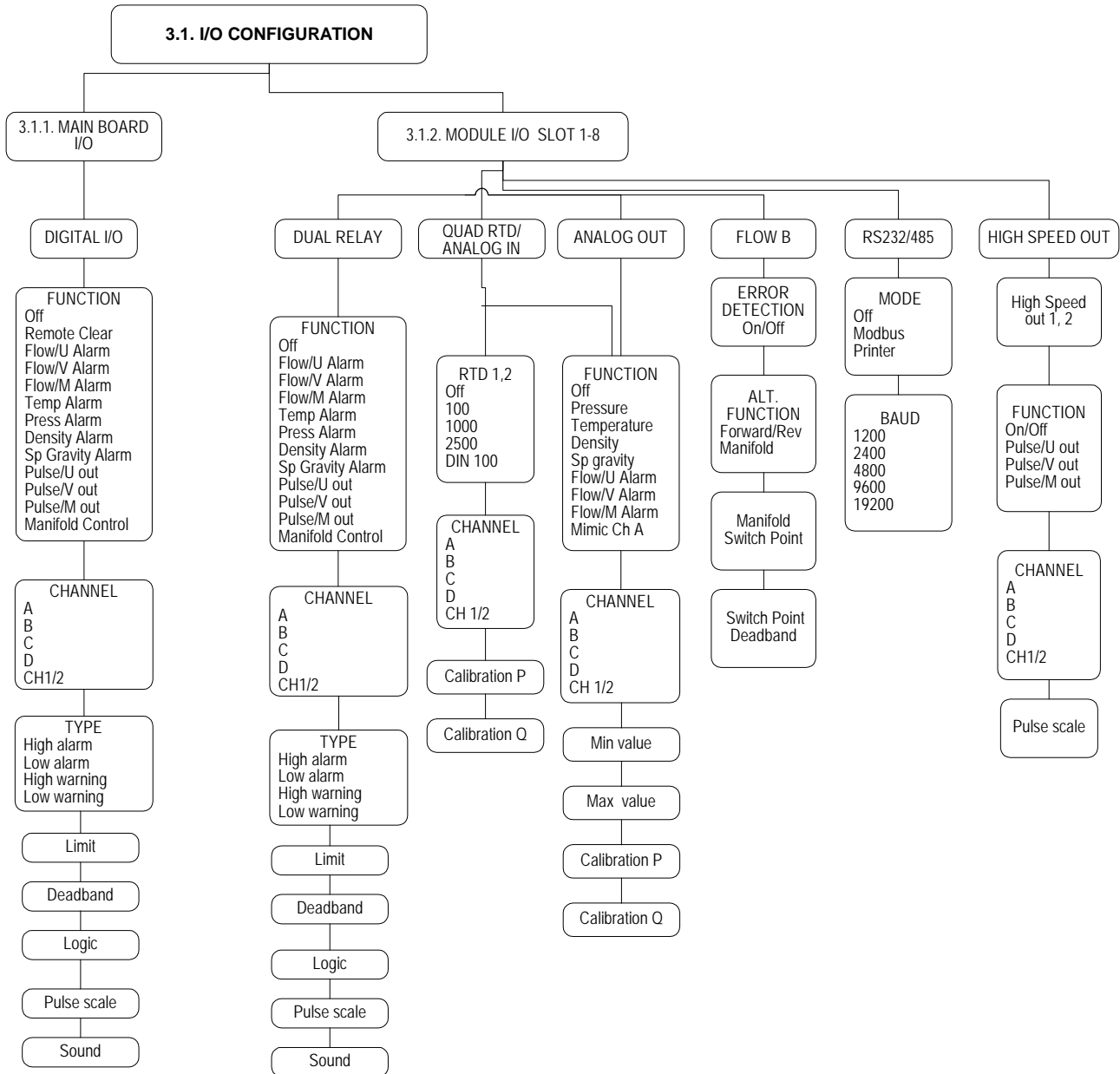

## Program Menu

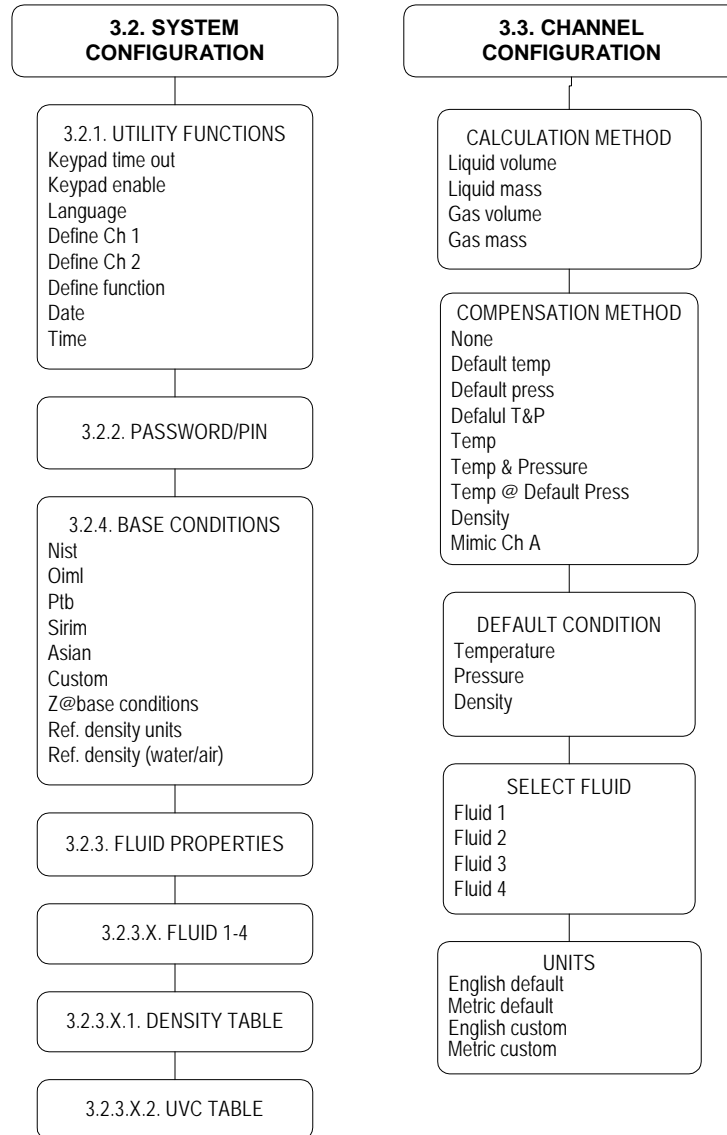

### Program Menu

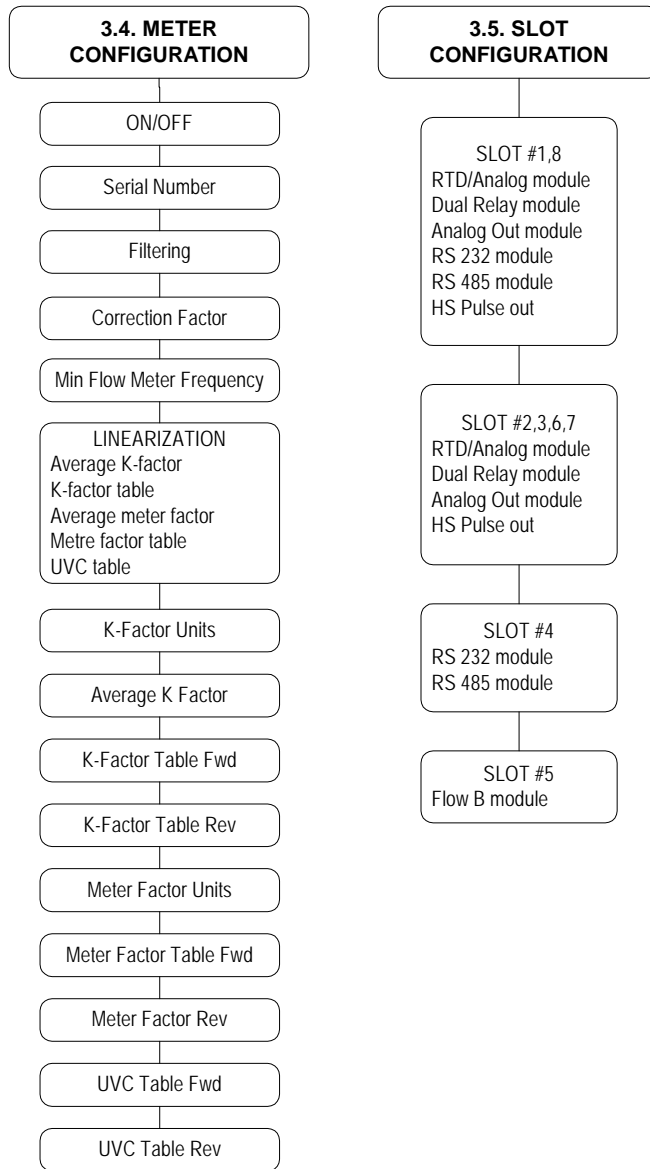

## 1. CLEAR Menu

1. Total CH A
2. Total CH B
3. Accum Total CH A
4. Accum Total CH B
5. Total CH C
6. Total CH D
7. Accum Total CH 1/2

Select an item from the above menu and press the CLEAR key. A message “Are you sure” will be displayed. Press YES key if you still want to clear a register. After pressing the YES key to confirm, information stored in the register will be lost.

## 2. PRINT Menu

1. Variables
2. Ticket
3. Audit Trail
4. Configuration Data

Select a desired item from the above menu and press the PRINT key.

Variables for printing may be selected from the following list located in the Windows Configuration program:

- Uncorrected Total
- Uncorrected Accumulated Total
- Total
- Accumulated Total
- Uncorrected Rate
- Rate
- Temperature
- Pressure
- Density

On multi-channel system variables are printed with extensions Ch A, Ch B, Ch C, or Ch D to identify the flow channel they are associated with.

Variables may be printed automatically at user-defined time intervals. This function is configured by entering an interval in minutes in the Print Frequency field located in the Windows Configuration Print Menu.

### NOTE

Selecting variables and setting the print time interval are available only from the Windows Configuration program.

### 3. PROGRAM Menu

#### NOTE

The Slot Assignments must be programmed before any other configuration can be performed, if the unit is being setup for the first time, or if there have been changes to the installed optional modules.

This section describes the program menu fields in detail. Whenever applicable the description is presented in the following format:

<i>Address</i>	<i>Menu item</i>	<i>Selection</i>	<i>Comments</i>
----------------	------------------	------------------	-----------------

A menu item can be accessed quickly from the Nova-Flow front panel by pressing the MENU key and the address number on the numerical keypad.

An alternative method of accessing a menu item is using SCROLL and SELECT keys as described in the Operation section.

The lowest level submenu items have no numerical address assigned, and selections are made using the SCROLL keys.

*Example:*

<i>Address</i>	<i>Menu</i>	<i>Selection</i>	<i>Comments</i>
3.2.1	Date/Time	Enter date and time	This menu allows to set time and date.

*To access the **Date/Time** field using numerical address:*

*press MENU key,  
press "3" key,  
press "2" key,  
press "1" key,  
scroll the selection bar down to Date/Time field.*

### 3.1. I/O Configuration

#### 3.1.1. Main Board I/O

I/O1 through I/O7 can be configured for input or output by selecting a dip switch combination on the main board. Outputs are configurable for 5V, 10Vdc, or open collector. I/O 8 is an output only and can be configured as an opto-isolated output. Refer to the Hardware configuration section for details.

<i>Address</i>	<i>Menu item</i>	<i>Selection</i>	<i>Comments</i>
3.1.1	Function	Remote clear Flow alarm Temperature alarm Pressure alarm Density alarm Sp gravity alarm Pulse out	Select a function for digital I/O line. Remote clear not available for I/O8.
3.1.1	Channel	Channel A Channel B Channel C Channel D CH1/2	Select applicable flow channel for digital I/O. This menu applies to multi-channel systems only.  CH1/2 is defined in System Configuration (3.2.1)
3.1.1	Type	High alarm Low alarm High warning Low warning	Select a desired alarm type. This menu applies to alarm output only. Warnings display message on the front panel, and sounds the buzzer if sound is selected. Alarms display message, sounds buzzer, and logs error message into the error log.
3.1.1	Limit	Number	Enter an alarm set point within the operating range of the parameter (Min-Max).
3.1.1	Deadband	Number	Enter a value in the currently selected units alarm to avoid spurious switching around the alarm set point. Recommended value is about 1-5% of the range.
3.1.1	Logic	Active low Active high	For active low the output changes from high level to low level when alarm condition occurs. For active high the output changes from low level to high level when alarm condition occurs.
3.1.1	Pulse scale	1, 10, 100, 1000	Select a scaling factor. This menu applies to pulse output only. "1" means one pulse is output for each unit of volume.
3.1.1	Pulse fwd/rev		Select forward or reverse flow for pulse output. This item is available on bi-directional flow system only.
3.1.1	Sound	On Off	Activates front panel buzzer when alarm condition occurs.

3.1.2. Module I/O Slots 1-8

<i>Address</i>	<i>Menu item</i>	<i>Selection</i>	<i>Comments</i>
3.1.2.1-8.	Slot 1-...8 module*	Varies with slots. Refer to table below	Select a slot to configure module installed in this slot.

In the actual configuration the word “module” in the menu item is replaced with the name of the module installed in this slot, according to the Slot Assignment settings, chapter 3.5.

Example:

- Slot 1- RS232
- Slot 2- RTD/Analog
- Slot 3- Relay
- Slot 4- RS232
- Slot 5- None
- Slot 6- None
- Slot 7- None
- Slot 8- None

The above examples represents a configuration consisting of four modules installed in slots 1-4. To configure a module, select a desired slot in which the module is installed, and follow the corresponding module menu.

<i>Slot</i>	<i>Compatible modules</i>
1	RTD/Analog Input, Analog output, Dual relay, Hi speed pulse out. RS232, RS485.
2	RTD/Analog Input, Analog output, Dual relay, Hi speed pulse out.
3	RTD/Analog Input, Analog output, Dual relay, Hi speed pulse out.
4	RS232, RS485.
5	Flow B.
6	RTD/Analog Input, Analog output, Dual relay, Hi speed pulse out.
7	RTD/Analog Input, Analog output, Dual relay, Hi speed pulse out.
8	RTD/Analog Input, Analog output, Dual relay, Hi speed pulse out. RS232, RS485.

## Relay Module

<i>Address</i>	<i>Menu item</i>	<i>Selection</i>	<i>Comments</i>
	Function	Flow alarm Temperature alarm Pressure alarm Density alarm Sp gravity alarm Pulse out Manifold Control	Select a function for relay output.
	Channel	Channel A Channel B Channel C Channel D CH1/2	Select applicable flow channel for relay output. This menu applies to multi-channel systems only.
	Type	High alarm Low alarm High warning Low warning	Select a desired alarm type. Warnings display message on the front panel, and sounds the buzzer if sound is selected. Alarms display message, sounds buzzer, and logs error message into the error log.
	Limit	Number	Enter an alarm set point within the operating range of the parameter (Min-Max) in the currently selected units.
	Deadband	Number	Enter a value in the currently selected units to avoid spurious switching around the alarm set point. Recommended value is about 1-5% of the range.
	Sound	On Off	Activates front panel buzzer when alarm condition occurs.

## RTD Input

<i>Address</i>	<i>Menu item</i>	<i>Selection</i>	<i>Comments</i>
<i>N/A</i>	RTD 1, 2	Off 100 1000 2500 DIN	Select a type of RTD probe. 100, 1000, 2500 are platinum 3902 material DIN is platinum 0385 material
<i>N/A</i>	Channel	Channel A Channel B Channel C Channel D	Select applicable channel.

**Analog Input 1, 2**

<i>Address</i>	<i>Menu item</i>	<i>Selection</i>	<i>Comments</i>
N/A	Function	Off Pressure Temperature Density Sp gravity Flow Mimic Ch A	Select a desired function for the analog input.  Mimic Ch A is used to copy analog input data from Ch A for the selected input function.
N/A	Channel	Channel A Channel B Channel C Channel D	Select applicable channel.
	Min value	Number	Enter a number corresponding to the minimum value for the input range, in the units selected for the input.
	Max value	Number	Enter a number corresponding to the maximum value for the input range, in the units selected for the input..
	Calibration P	Number	See calibration procedure
	Calibration Q	Number	See calibration procedure

**Analog Output Module**

<i>Address</i>	<i>Menu item</i>	<i>Selection</i>	<i>Comments</i>
N/A	Function	Off Pressure Temperature Density Sp gravity Flow	Select a desired function for the analog output.
N/A	Channel	Channel A Channel B Channel C Channel D	Select applicable channel.
	Min value	Number	Enter a number corresponding to the minimum value for the input range.
	Max value	Number	Enter a number corresponding to the maximum value for the input range.
	Calibration P		See calibration procedure.
	Calibration Q		See calibration procedure.

## Split Analog Out

A split analog output is available for Forward/Reverse applications. 4 mA is maximum reverse flow, 12 mA is 0 flow, and 20 mA is maximum forward flow. The FWD/REV function in the I/O Configuration for Flow B must be enabled. When entering Min and Max parameters for the Analog Output Configuration, enter the maximum reverse flow rate in the Min field preceded with a negative sign(-). Enter the maximum forward flow rate in the Max field.

## Flow B Module

<i>Address</i>	<i>Menu item</i>	<i>Selection</i>	<i>Comments</i>
N/A	Error Detection	On Off	Activates transmission error detection circuit on dual coil meter systems. The circuit detects missing pulses or pulses induced on the transmission lines.
	Alt Function	Independent Forward/Reverse Manifold	Select Independent for independent operation of Channel A and Channel B. Select Forward/Reverse for bi-directional meters. Forward and reverse flow are being counted into registers A and B, respectively.
	Manifold Switch Level	Number	Enter a number corresponding to a manifold switch point in units of volumetric flow rate.
	Manifold Switch Deadband	Number	Enter a number corresponding to a manifold switch deadband in units of volumetric flow rates. The switch point value has to be within the overlapping range of the meters.

## Manifold Application

In manifold application Channel A is assigned to the high flow range meter and Channel B is assigned to the low flow range meter. A combined total from both meters is calculated using A+B function. The manifold relay is activated and the manifold valve is closed when Nova Flow is powered up. The relay is deactivated and the valve is opened when flow rises above the value of Manifold Switch Point + Deadband. The relay is activated and the manifold valve is closed when flow drops below the Manifold Switch Point.

## RS232 Module

<i>Address</i>	<i>Menu item</i>	<i>Selection</i>	<i>Comments</i>
N/A	Mode	Off Modbus Printer	Select Modbus for communication with a PC computer or Modbus master device. Select Printer for printing function.
	Baud	1200 2400 4800 9600 19200	Select a desired baud rate.

### RS485 Module

<i>Address</i>	<i>Menu item</i>	<i>Selection</i>	<i>Comments</i>
N/A	Mode	Off Modbus	Select Modbus for communication with a PC computer or Modbus master device.
	Baud	1200 2400 4800 9600 19200	Select a desired baud rate.

### Pulse Output Module

<i>Address</i>	<i>Menu item</i>	<i>Selection</i>	<i>Comments</i>
N/A	Function	On/Off Pulse/U Pulse/V Pulse/M	Select a function for the pulse out: U- uncorrected volume V- corrected volume M- mass
	Channel	Channel A Channel B Channel C Channel D CH1/2	Select a flow channel

## 3.2. System Configuration

### 3.2.1. Utility Functions

<i>Address</i>	<i>Menu item</i>	<i>Selection</i>	<i>Comments</i>
	Keypad enable	Yes No	If “No” is selected the front panel keys are disabled. To enable, press any key and enter a password when prompted.
	Keypad time out	Enter a number of seconds Range: 0-	If the unit is left in the program mode, it will switch back to the operate mode when limit is reached. Zero means the time out function is disabled.
	Language	English Spanish	Select a desired language.
	Date/Time	Enter date and time	This menu is used to set time and date.
	Define Ch1	Ch A Ch B	This function allows to calculate combined (+ or -) total from two flow channels. Assign channel A or B for operand Ch1 for math calculations.
	Define Ch2	Ch B Ch C Ch D	Assign channel B, C, or D for operand Ch2 for math calculations.
	Define function	Ch1-Ch2 Ch1+Ch2	Select addition or subtraction for calculating a net total.

### 3.2.2. Password/Pin

<i>Address</i>	<i>Menu item</i>	<i>Selection</i>	<i>Comments</i>
	Supervisor pin #1-5	Number	Enter a 4 digit for each supervisor pin number.
	Supervisor password	Number	Enter a 4 digit for supervisor password.
	Reenter password	Number	Enter the supervisor password again to confirm.
	Operator pin #1-5	Number	Enter a 4 digit for each operator pin number.
	Operator password	Number	Enter a 4 digit for operator password.
	Reenter password	Number	Enter the operator password again to confirm.

### 3.2.3. Fluid Properties

#### Density Table

<i>Address</i>	<i>Menu item</i>	<i>Selection</i>	<i>Comments</i>
3.2.3	Default conditions T, P, D, Sp Gravity	Number	Enter default temperature, pressure, density and specific gravity. Default values are used for calculation when a sensor fails, or when “default” is selected for compensation method.

### 3.2.4. Base Conditions

<i>Address</i>	<i>Menu item</i>	<i>Selection</i>	<i>Comments</i>
3.2.3.	Base conditions	NIST OIML PTB SIRIM ASIAN NORMAL CUSTOM NBP	Select a predefined set of base conditions, or select “custom” to enter user defined base conditions. Base conditions are used to calculate corrected volume.

### 3.3. Channel Configuration

<i>Address</i>	<i>Menu item</i>	<i>Selection</i>	<i>Comments</i>
3.3.	Calculation method	Liquid volume Liquid mass Gas volume Gas mass	Select an appropriate calculation method. When “volume” is selected, mass flow rate and mass total are not available. Liquids calculations are based on fluid property table programmed in the Nova Flow. Gas calculations are based on ideal gas equation and Z table programmed in the Nova Flow.
3.3.	Compensation method	Default temperature Default pressure Default T&P Temperature T&P Density T,P, &D  *Mimic CHA	Select an appropriate compensation method. For T, P, D compensation an associated sensor has to be connected and an analog input has to be programmed accordingly. When a sensor fails, the default value is used for calculations.  *Mimic CHA is added to the list of Compensation Methods for Channels B, C, and D. When this method is selected, compensation parameters for channel A are applied to the designated channel.
3.3.	Select fluid	Fluid 1 Fluid 2 Fluid 3 Fluid 4	Select a fluid table for the current flow channel. Up to four different fluids can be programmed in the Nova Flow and switched between flow channels A, B, C, D.
3.3.	Units	English default English custom Metric default Metric custom	Select a desired set of units of measure. For a complete list of available units and conversion factors refer to appendix xx.

### 3. 4. Meter Configuration

<i>Address</i>	<i>Menu item</i>	<i>Selection</i>	<i>Comments</i>
3.4.1.	On/off	On Off	“On” has to be selected to activate the flow channel operation.
	Filtering	Number	This number represents the amount of smoothing applied to the input signal coming from a meter. Default value is...
	Serial number	Number	Enter up to a 10- digit flow meter serial number
	Correction factor	Number	User selected number to correct the flow rate and total. Range: 0.5-1.5. Default value is 1.
	Linearization	Average K-factor K-factor table Average meter factor Meter factor table UVC table	Select an applicable method. The menus below will be displayed only when the associated method is selected.
	Minimum meter frequency	Number	Enter a frequency in Hz that is below an operating range of input frequency. Any signal at frequency below the min. value is considered a “noise” and it will be rejected. Default value is 0.
	K-factor units		Select units of measure for K-factor
	Average K-factor	Number	This menu is displayed when Average K-factor selected for linearization method. Enter a K-factor for the meter connected to this channel.
	K-factor table forward		This menu is displayed when K-factor table fwd is selected for linearization method. For every point of the table enter frequency in Hz and K-factor value.
	Meter factor units		Select units of measure for meter factor
	Average meter factor	Number	This menu is displayed when Average meter factor is selected for linearization method.
	Meter factor table		This menu is displayed when Meter factor table is selected for linearization method. For every point of the table enter frequency in Hz and K-factor value.
	UVC table		This menu is displayed when UVC table is selected for linearization method. For every point of the table enter frequency/viscosity in Hz/ctsk and K-factor value.

### 3.5. Slot Configuration

For each slot (1-8) select the module type that is installed in this slot. Select NONE, if there is no module installed in the slot. Note that the list of available modules for a given slot varies from slot to slot, according to the slot/module compatibility table.

<i>Address</i>	<i>Menu item</i>	<i>Selection</i>	<i>Comments</i>
3.5.1.	Slot 1	None RTD/Analog Input Analog output Dual relay Pulse out RS232 RS485	Select a module that is installed in this slot.
3.5.2.	Slot 2	None RTD/Analog Input Analog output Dual relay Pulse out	Select a module that is installed in this slot.
3.5.3.	Slot 3	None RTD/Analog Input Analog output Dual relay Pulse out	Select a module that is installed in this slot.
3.5.4.	Slot 4	None RS232 RS485	Select a module that is installed in this slot.
3.5.5.	Slot 5	None Flow B	Select a module that is installed in this slot.
3.5.6.	Slot 6	None RTD/Analog Input Analog output Dual relay Pulse out	Select a module that is installed in this slot.
3.5.7.	Slot 7	None RTD/Analog Input Analog output Dual relay Pulse out	Select a module that is installed in this slot.
3.5.8.	Slot 8	None RTD/Analog Input Analog output Dual relay Pulse out RS232 RS485	Select a module that is installed in this slot.

#### 4. DIAGNOSTICS Menu

Nova-Flow provides diagnostic functions for testing Inputs and Outputs to verify hardware functionality. The Diagnostics Menu is conveniently located in the Main Menu at address 4. The table below illustrates the way in which the Diagnostics Menu is organized. This menu will change depending on how the I/O slots are assigned.

Address	Menu Option
4.1	Main board DigIO
4.2	Slot1 – Assigned Module Name
4.3	Slot2 – Assigned Module Name
4.4	Slot3 – Assigned Module Name
4.5	Slot4 – Assigned Module Name
4.6	Slot5 – Assigned Module Name
4.7	Slot6 – Assigned Module Name
4.8	Slot7 – Assigned Module Name
4.9	Slot8 – Assigned Module Name

*Organization of Diagnostics Menu*

#### Main Board Digital I/O

The Main board consists of 8 Digital I/O lines, of which I/O1-I/O7 can be configured as an input or an output and I/O8 only as an output. The figure below illustrates the layout of the Main board Digital I/O diagnostics screen. The 1s and 0s represent corresponding I/O lines, counting from left to right. For example, the first digit corresponds to I/O1, the next to I/O2, and so forth. A 1 represents a high signal level and 0 a low signal level. When a signal is applied to an input, the corresponding digit will toggle accordingly. When configured as an output, presses SELECT to highlight the appropriate I/O and use the SCROLL keys to toggle the output between high and low levels. The output may be monitored with an oscilloscope.

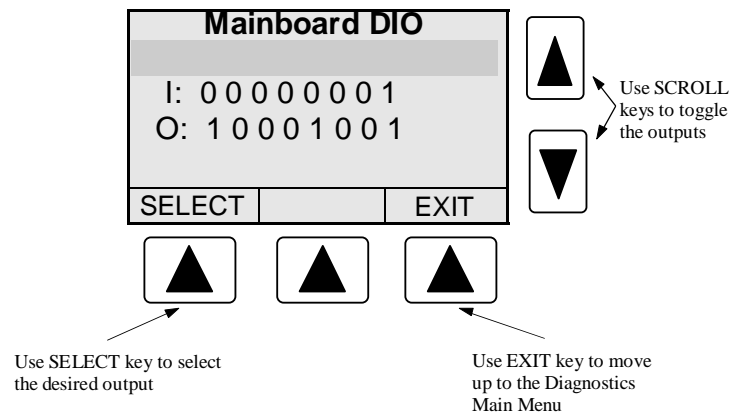

Figure 1. Main board Digital I/O Diagnostics Screen

### Dual Relay Module

The relays may be tested by connecting an Ohmmeter or a continuity tester to the corresponding output pins of the module. Pressing the SELECT key toggles between Relay1 and Relay 2. Use the SCROLL Keys to activate and deactivate the relays. A 1 activates the relay and a 0 deactivates the relay.

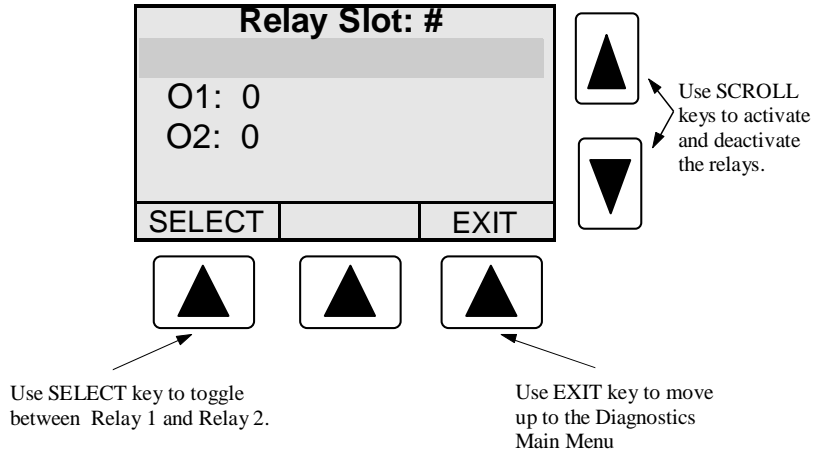

Figure 2. Dual Relay Diagnostics Screen

### Dual Pulse Output Module

The pulse outputs may be tested by connecting an Oscilloscope or a Voltmeter to the corresponding output pins of the module. Pressing the SELECT key toggles between Output1 and Output2. Use the SCROLL Keys to toggle the outputs between high and low. A 1 outputs a high signal and a 0 a low signal.

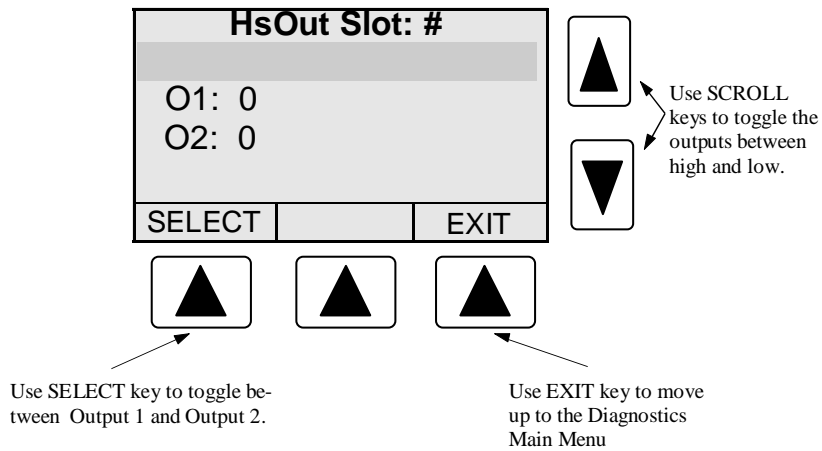

Figure 3. Pulse Output Diagnostics Screen.

## Analog Output Module

The Analog Output Module may be tested by connecting a current measuring device, such as an amp meter, to the output pins of the module. Pressing the SELECT key selects the output. Use the SCROLL keys to increase or decrease the number of D/A counts. As the number increases, the output current should increase. As the number decreases, the output current should decrease. The range of D/A counts is from 0 to 4095.

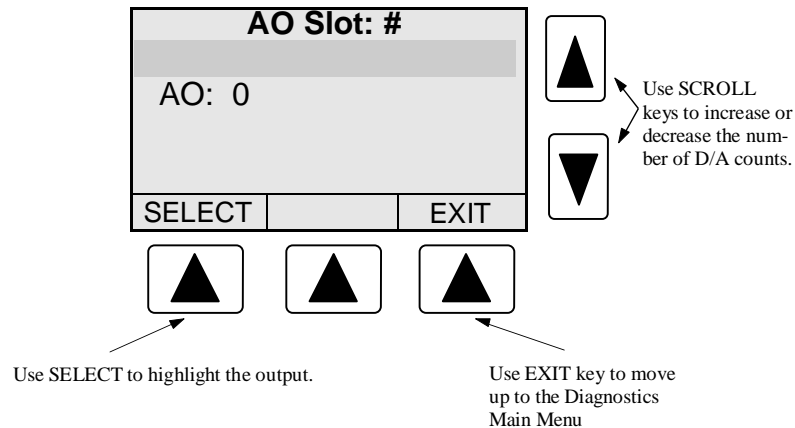

Figure 4. Analog Output Diagnostics Screen.

## RTD/ Analog Input Module

Operation of an installed RTD/Analog module may be verified using diagnostics. There are four Analog Input labels each displaying a number of A/D counts. RTD1 and RTD2 correspond to the 2 RTD inputs, while AI1 and AI2 correspond to the 2 analog inputs. A/D counts for a configured input should always be between 0 and 4095 during normal operation. As the transmitter signal increases, the number of A/D counts should increase. As the RTD temperature increases, the number of A/D counts should increase. If the counts become 0 or 4095, either the module has not been installed, configured, or calibrated, or there is an RTD or Transmitter failure.

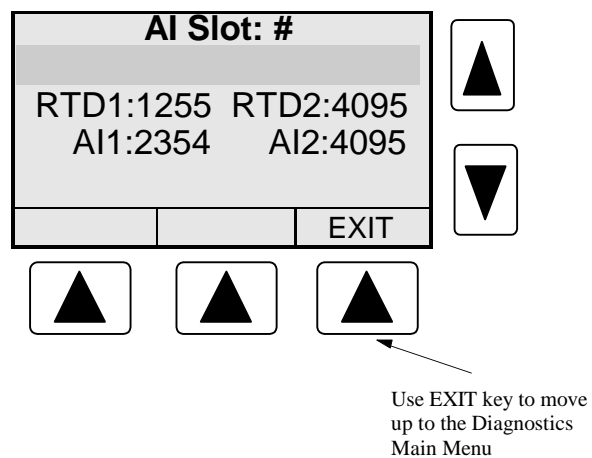

Figure 5. RTD/Analog Input Diagnostics Screen.

**5. BASE CONDITIONS**

Base temperature and pressure selected in the program menu can viewed in this menu.

Nova Flow uses base conditions to calculate corrected total volume and corrected flow rate.

# Communications

---

Nova Flow can be equipped with up to three serial ports and the infrared port. Serial ports can be used for programming the Nova-Flow, printing, communication with a personal computer, or with a Modbus master device. When all three ports are installed and active, the priority is given to the communication port in Slot 4.

For programming Nova-Flow from a personal computer using Hoffer configuration program refer to the Windows configuration section.

For serial port wiring refer to the Installation section.

Nova-Flow supports standard MODBUS RTU (binary) encoding.

The following tables provide memory mapping for all available Modbus commands.

## Function Code 04 (Read Input Registers)

ABSOLUTE ADDRESS	DESCRIPTION
30001	CHA Uncorrected Rate X 10
30002	CHA High Word of Uncorrected Total
30003	CHA Low Word of Uncorrected Total
30004	CHA High Word of Uncorrected Accum Total
30005	CHA Low Word of Uncorrected Accum Total
30006	CHA Corrected Rate X 10 (Mass or Volume)
30007	CHA High Word of Corrected Total
30008	CHA Low Word of Corrected Total
30009	CHA High Word of Corrected Accum Total
30010	CHA Low Word of Corrected Accum Total
30011	CHA Pressure
30012	CHA Density X 1000
30013	CHA Temperature (Kelvin)
30014	OPEN
30015	OPEN
30016	OPEN
30017	CHB Uncorrected Rate X 10
30018	CHB High Word of Uncorrected Total
30019	CHB Low Word of Uncorrected Total
30020	CHB High Word of Uncorrected Accum Total
30021	CHB Low Word of Uncorrected Accum Total
30022	CHB Corrected Rate X 10 (Mass or Volume)
30023	CHB High Word of Corrected Total
30024	CHB Low Word of Corrected Total
30025	CHB High Word of Corrected Accum Total
30026	CHB Low Word of Corrected Accum Total
30027	CHB Pressure
30028	CHB Density X 1000
30029	CHB Temperature (Kelvin)
30030	OPEN
30031	OPEN
30032	OPEN
30033	CHC Uncorrected Rate X 10

<b>ABSOLUTE ADDRESS</b>	<b>DESCRIPTION</b>
30034	CHC High Word of Uncorrected Total
30035	CHC Low Word of Uncorrected Total
30036	CHC High Word of Uncorrected Accum Total
30037	CHC Low Word of Uncorrected Accum Total
30038	CHC Corrected Rate X 10 (Mass or Volume)
30039	CHC High Word of Corrected Total
30040	CHC Low Word of Corrected Total
30041	CHC High Word of Corrected Accum Total
30042	CHC Low Word of Corrected Accum Total
30043	CHC Pressure
30044	CHC Density X 1000
30045	CHC Temperature (Kelvin)
30046	OPEN
30047	OPEN
30048	OPEN
30049	CHD Uncorrected Rate X 10
30050	CHD High Word of Uncorrected Total
30051	CHD Low Word of Uncorrected Total
30052	CHD High Word of Uncorrected Accum Total
30053	CHD Low Word of Uncorrected Accum Total
30054	CHD Corrected Rate X 10 (Mass or Volume)
30055	CHD High Word of Corrected Total
30056	CHD Low Word of Corrected Total
30057	CHD High Word of Corrected Accum Total
30058	CHD Low Word of Corrected Accum Total
30059	CHD Pressure
30060	CHD Density X 1000
30061	CHD Temperature (Kelvin)
30062	OPEN
30063	OPEN
30064	OPEN

**Funtion Code 01 (Coil Status)**

<b>ABSOLUTE ADDRESS</b>	<b>DESCRIPTION</b>
00002-00008	OPEN
00009	Clear Totals for Ch A
00010	Clear Accum Totals for Ch A
00011	Clear Totals for Ch B
00012	Clear Accum Totals for Ch B
00013	Clear Totals for Ch C
00014	Clear Accum Totals for Ch C
00015	Clear Totals for Ch D
00016	Clear Accum Totals for Ch D

# Installation

## Notes:

1. The terminal marked with safety ground symbol must be connected to the earth ground, using a multi-stranded, braided wire.
2. To minimize susceptibility to electromagnetic noise, all sensor connections must be made using shielded twisted pair wires and shields must be connected to the designated shield or earth terminals on the Nova-Flow rear panel.
3. Signal cables must be separated from power line and relay cables to minimize possible interference problems.

## Main Connector

Figure 1 indicates the location of the Main Connector on the Nova-Flow rear panel. This 18-pin connector provides connections for a flow meter input, an AC or DC power supply input, an auxiliary 24 Vdc output, and 8 digital I/O lines. The pages that follow, illustrate typical connections made to the main connector.

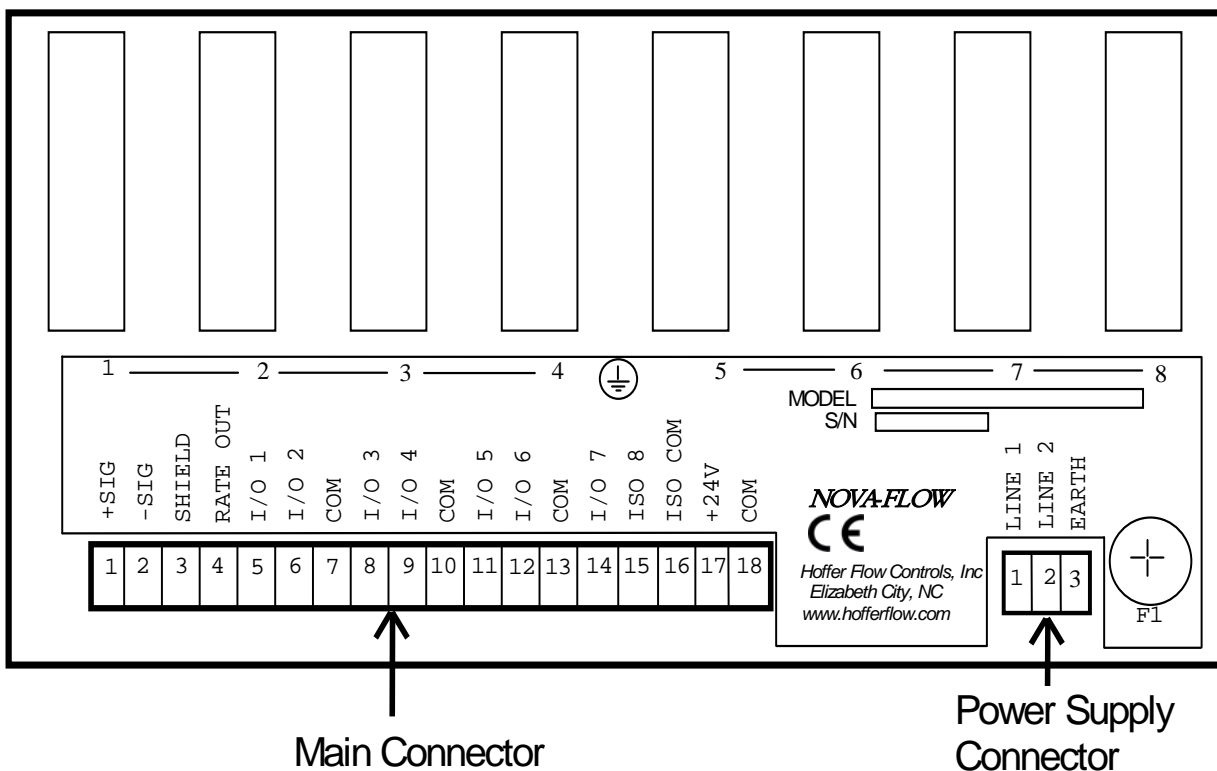

Figure 1. Main Connector on the Nova-Flow Rear Panel.

## Power Supply Connections

**Warning!** Before connecting power supply lines, verify the power supply rating indicated on the Nova-Flow unit.

Note: The power input is protected by a fuse accessible from the back panel and is designated as F1. The specified fuse rating is AGC 2 Amp/250 V.

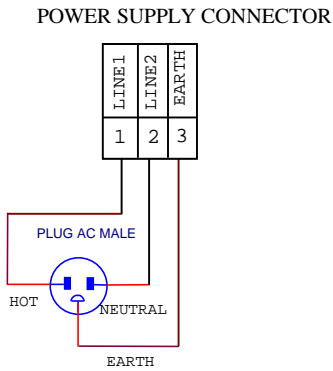

Figure 2. 120/240 VAC Power Line connection

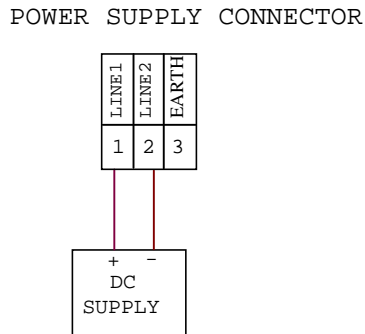

Figure 3. 10-30 VDC Power Line connection

## Pickup Coil Connections

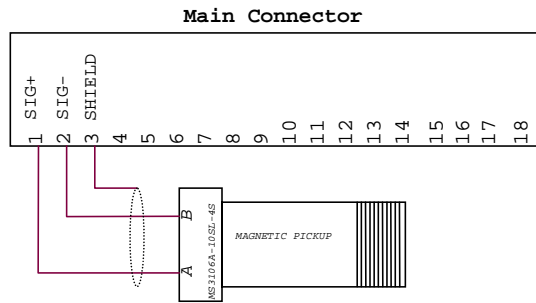

Figure 4. Magnetic Coil Connection

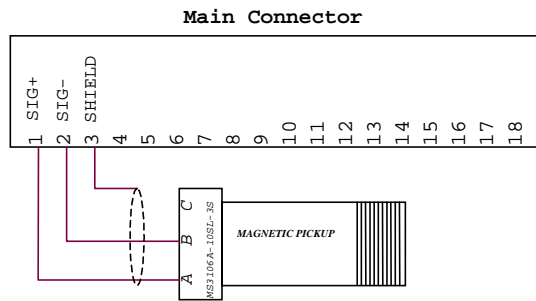

Figure 5. MCP Coil Connection

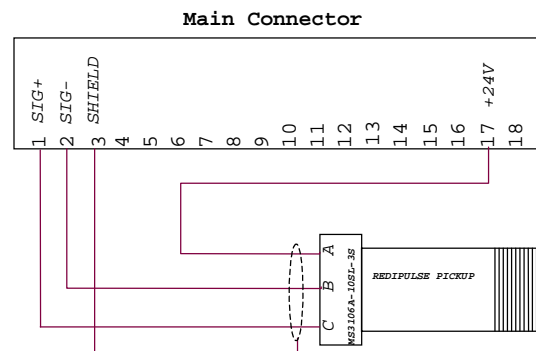

Figure 6. Redi-Pulse/Open Collector Coil Connection

**I/O1 - I/O7 Connections**

The following figures illustrate example input and output connections for I/O1 – I/O7. Please refer to the Hardware Configuration section of this manual for details on the proper hardware configuration of these options.

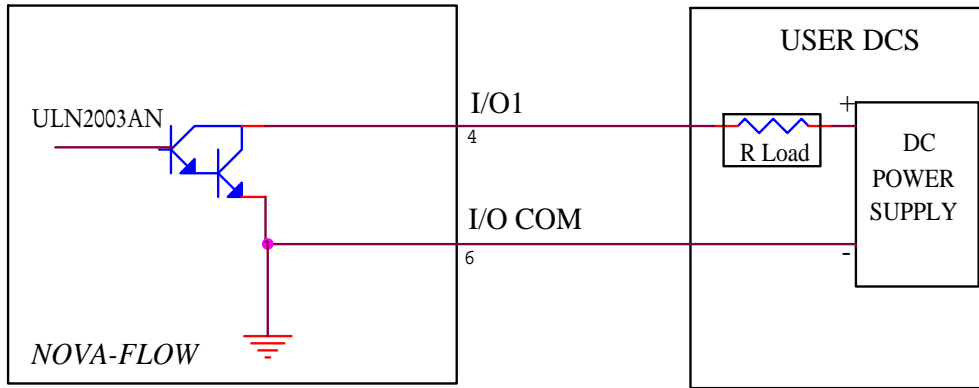

Figure 7. I/O1 Configured for Open Collector Output

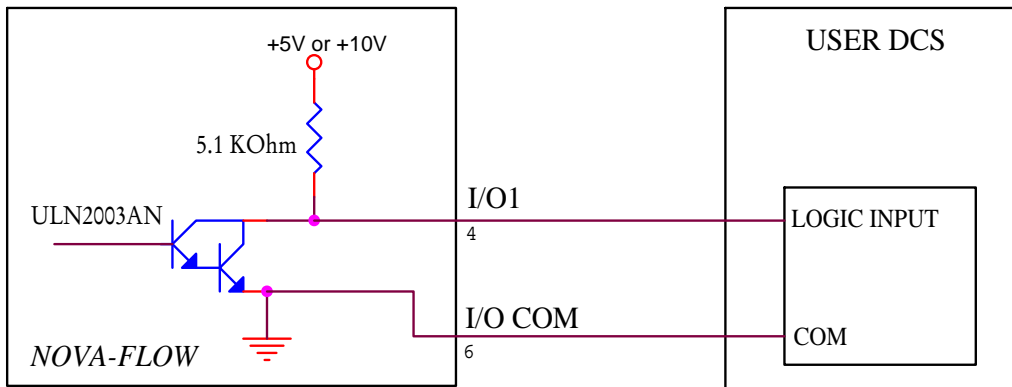

Figure 8. I/O1 Configured for 5V or 10V Output

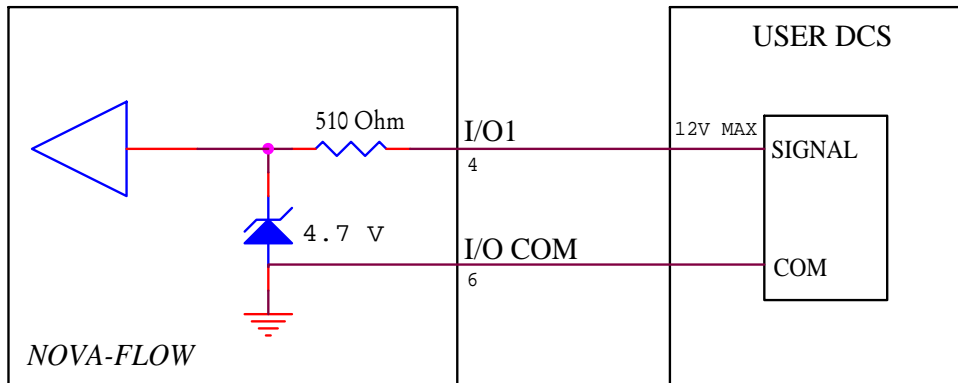

Figure 9. I/O1 Configured as an Input

I/O8

I/O8 is an output only. It can be configured for isolated output, open collector referenced to internal ground, or digital output at 5V or 10V level referenced to internal ground. Please refer to the Hardware Configuration section of this manual for details on the proper hardware configuration of these options.

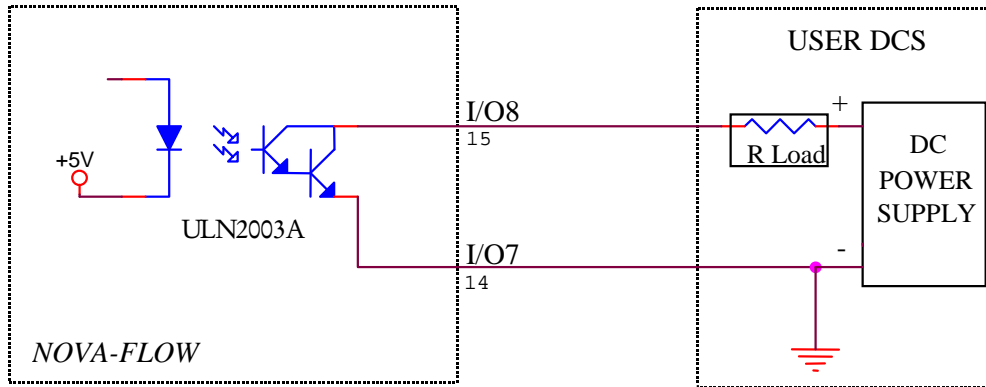

Figure 10. I/O8 Configured for Isolated Output

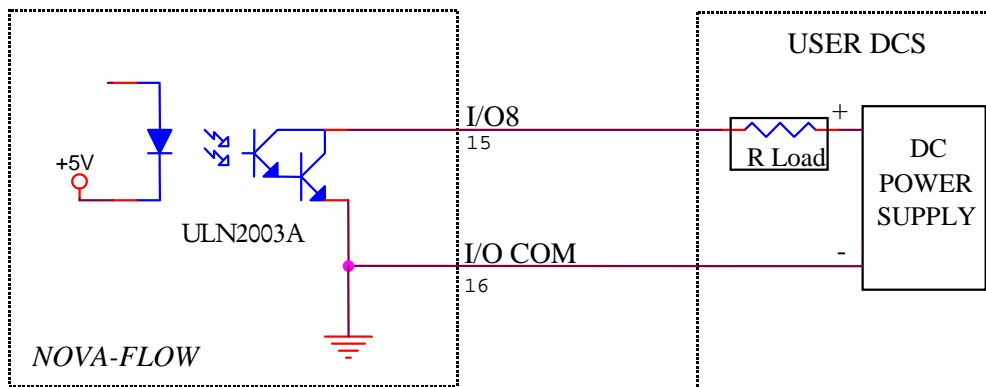

Figure 11. I/O8 Configured for Open Collector Output Referenced to Internal Ground.

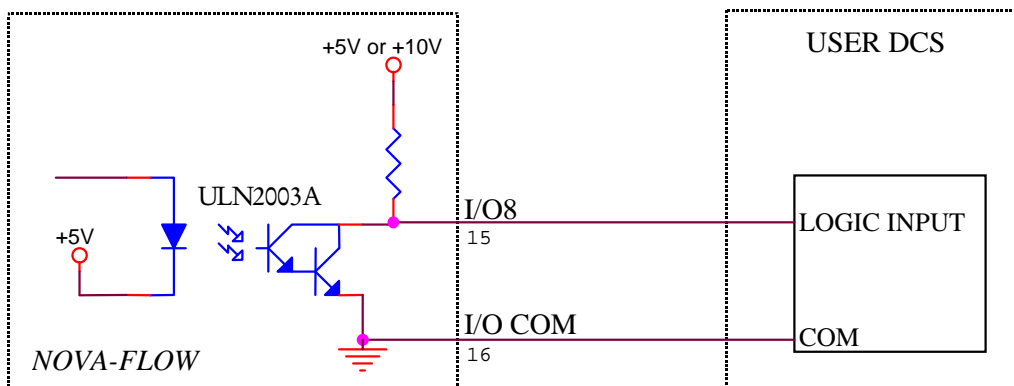

Figure 12. I/O8 Configured for 5V or 10V Outputs Internally Referenced.

## Flow B Module Connections

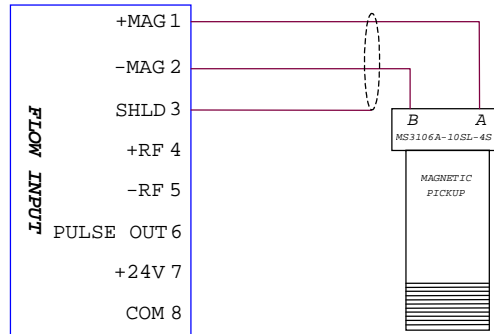

Figure 13. Magnetic Coil Connection

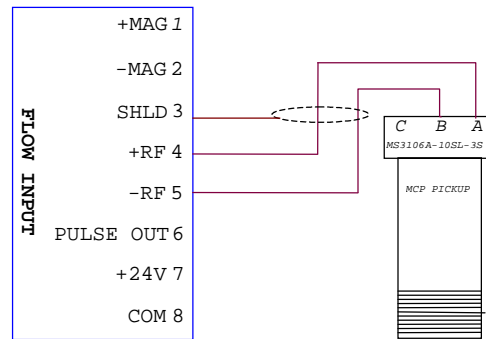

Figure 14. MCP Coil Connection

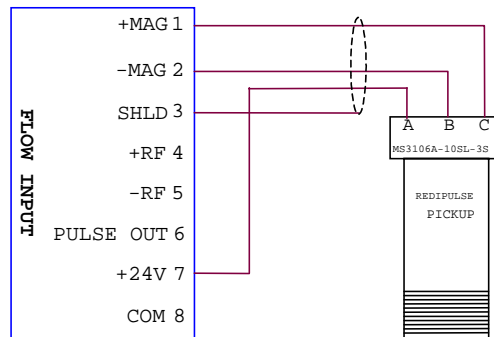

Figure 15. Redi-Pulse/Open Collector Coil Connection

### RTD/Analog Input Module

NOTE: Loop powered devices cannot be connected when using true four-wire RTD configuration since pin 8 will be COM instead of +24V as selected by internal jumper. Refer to the Hardware Configuration section of this manual for details.

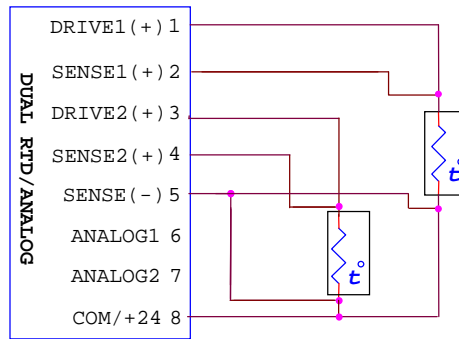

Figure 1. Four-Wire RTD Connection.

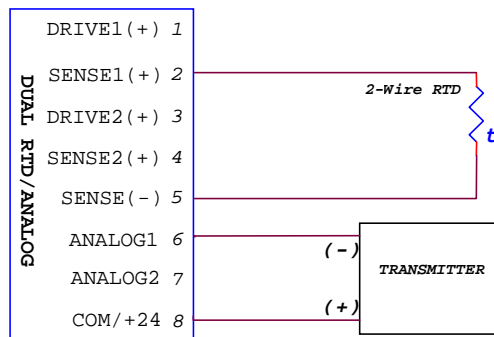

Figure 17. Two-Wire RTD and Transmitter Connection.

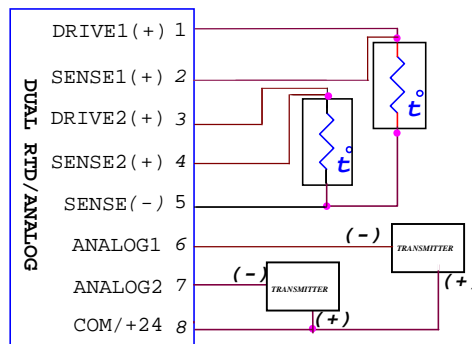

Figure 18. Three-Wire RTD and Transmitter Connection.

## Analog Output Module

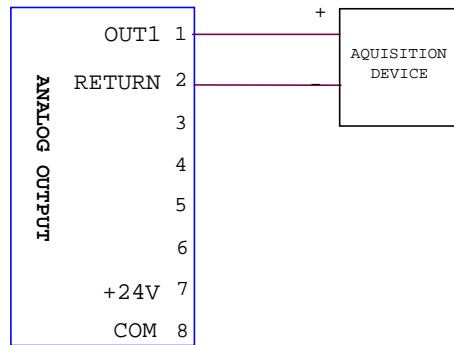

Figure 19. Analog Output Using Internal Power Supply (Sourcing).

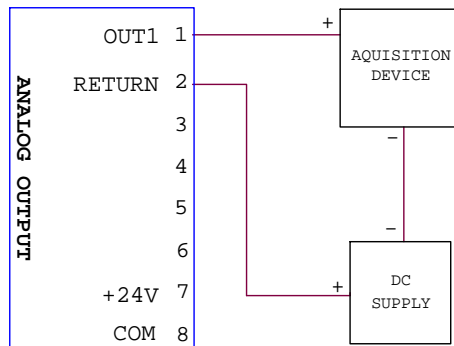

Figure 20. Analog Output Using External Power Supply (Sinking).

### Dual Pulse Output Module

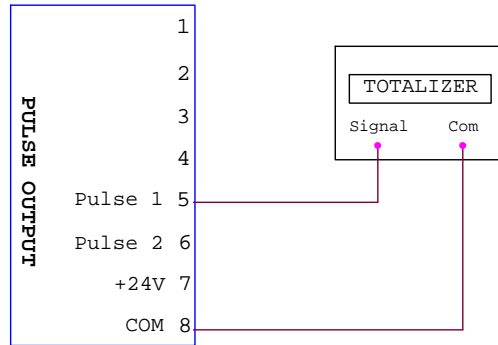

Figure 21. Pulse Output Connection.

### Dual Relay Module

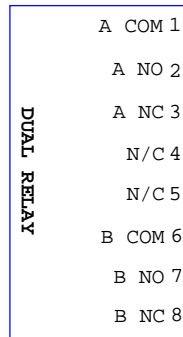

Figure 22. Dual Relay Connections.

Communications

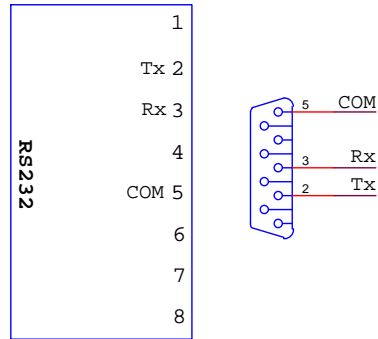

Figure 23. RS-232 Connections for Optional 8 Pin or DB-9 Connector.

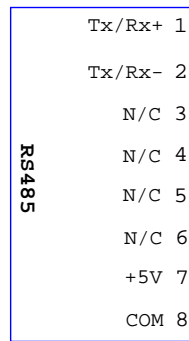

Figure 24. RS-485 Connections.

**THIS PAGE LEFT INTENTIONALLY BLANK**

# Hardware Configuration

---

## I/O Configuration

SW1, SW2, and SW3 are used for configuration of Main board I/O functions. The switches are located on the rear of the main board near the main connector.

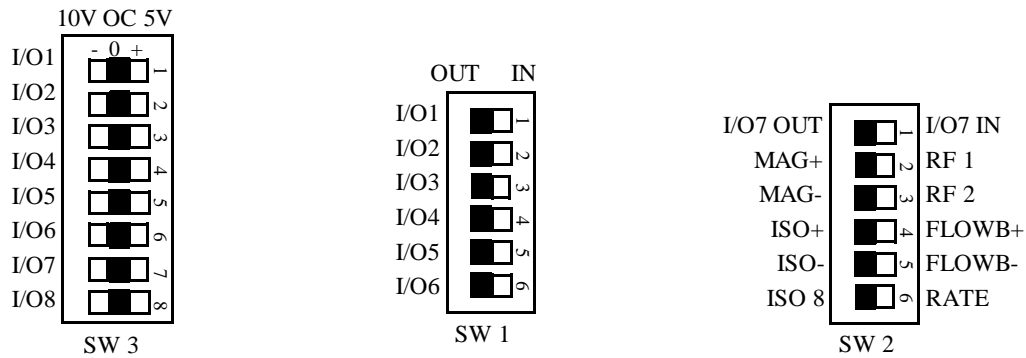

Figure 1. I/O Configuration Switches SW1, SW2, and SW 3.

**Flow Input Selection**

SW3 is used for selecting the type of flow input that will be used. The following figures illustrate the proper switch settings for a variety of flow sensors.

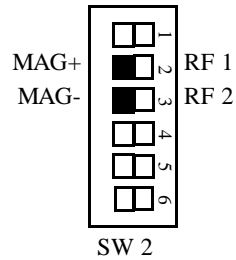

Figure 2. Magnetic Pickup Coil

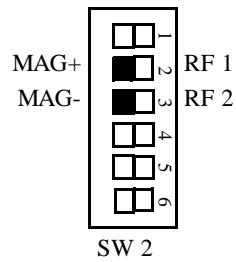

Figure 3. Redi-Pulse/Open Collector Coil Connection.

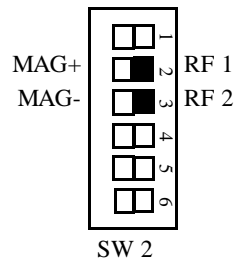

Figure 4. MCP Coil Connection

### Dual Coil Pulse Security

Flow B Module must be installed for the Pulse Security Function. Digital I/O8 is not available when Pulse Security is enabled. Figure 16 illustrates the proper switch settings to enable pulse security.

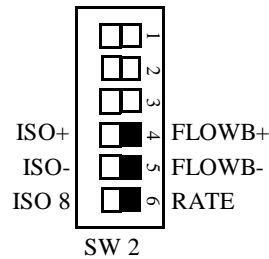

Figure 5. Switch Settings to Enable Pulse Security

### Digital I/O 1-7

I/O1 – I/O7 can be configured individually for input or output by setting SW1 and SW2-1. When configured as an output, SW1 is used to select whether the output is 5V, 10V, or Open Collector.

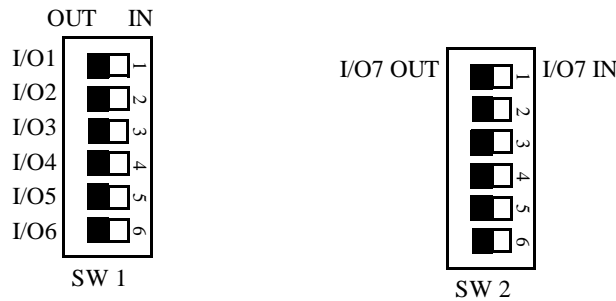

Figure 6. SW1 and SW2-1 for Selecting Digital Input or Output(Shown Configured as Output).

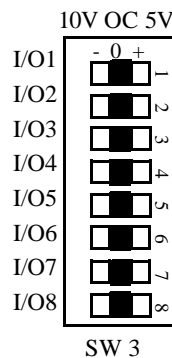

Figure 7. Selecting 5V, 10V, or Open Collector Output on SW3(Shown Configured as Open Collector).

Digital I/O8

I/O8 is an output only. It can be configured for isolated output, open collector referenced to internal ground, or digital output at 5V or 10V level referenced to internal ground. The following figures illustrate settings for typical configurations.

**NOTE:** I/O7 is not available when I/O8 is configured as an Isolated Output.

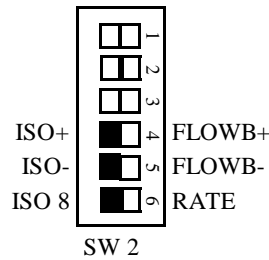

Figure 8. I/O8 Configured as an Isolated Output

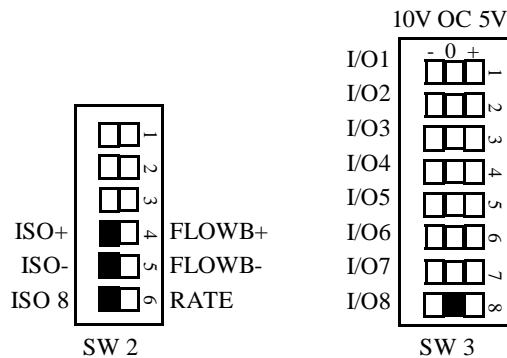

Figure 9. I/O8 Configured as an Open Collector Output Referenced to Internal Ground.

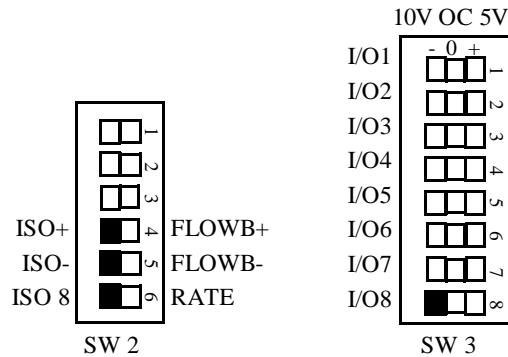

Figure 10. I/O8 Configured as a 10V Output Referenced to Internal Ground.

## RTD/Analog Input Module

	2 -Wire RTD	3-Wire RTD	4 -Wire RTD
SW1-1	ON	X	OFF
SW1-2	ON	OFF	OFF
SW1-3	ON	OFF	OFF
SW1-4	ON	ON	OFF

Table 2. SW1 Settings for RTD Input.

RTD Resistance	R1, R2	R4, R5, R9, R10	R3, R8
RTD 100	2 k	1 k	Not installed
RTD 1000	20 k	1 k	Not installed
RTD 2500	50 k	1 k	Not installed

Table 3. Resistor Values for Optional RTD Input Configurations.

**Note:** All resistors are factory installed. Values listed are for reference only.

Input Signal	Resistor A	Resistor B	Resistor C
4-20 mA	10	10	200
1-5 V	1k	1.5k	8.45k

Table 4. Resistor Values for Optional Analog Input Configurations.

**Note:** All resistors are factory installed. Values listed are for reference only

### Pin 8: Auxiliary 24V / COM

There is an auxiliary 24V supply provided for loop-powered devices on pin 8. This option must be selected by equipping JP2 on the module. Pin 8 may also be used as a reference Ground for 4-wire RTD applications by equipping JP1.

**Note:** JP1 and JP2 should never be equipped simultaneously, as this will cause a power supply short. Loop powered devices cannot be used on a module that requires true 4-wire RTD connections.

**Analog Output Module**

Analog Output may be configured for 4-20 mA or 1-5 V output, and may be powered internally or externally using removable jumpers JP1-JP4 and Pins 1 and 2 of the eight-pin connector.

	<b>JP1</b>	<b>JP2</b>	<b>JP3</b>	<b>JP4</b>	<b>Pins1&amp;2 on P1 connector</b>
Externally Powered 4-20 mA		Installed			
Internally Powered 4-20 mA	Installed		Installed		
1-5 V	Installed			Installed	Installed

Table 5. Jumper Settings for Power and Output Options.

**Pulse Output Module**

The Pulse Output signal level can be configured for open collector, 5V, or 12V using removable jumpers JP1-JP4. Do not install jumpers for open collector output.

<b>Output level</b>	<b>Pulse 1</b>	<b>Pulse 2</b>
5 V Output	JP2	JP4
12 V Output	JP1	JP3
Open Collector	NONE	NONE

Table 6. Jumper Settings for Optional 5V or 12V Output Level.

# Windows Configuration

The Nova-Flow WinConfig Program allows for quick, easy configuration of the Nova-Flow using a personal computer. Any programmable field available locally on the flow computer is also accessible through WinConfig. This chapter provides guidelines for basic operations available through WinConfig.

## Installation

Minimum system requirements: 486 Processor running Windows 95/NT and a Communications Port.

Insert the provided disk into the computer.  
Click on the “Start” menu on the Windows desktop taskbar and select “Run”.  
Click on “Browse” and search for the drive in which the disk is located.  
Select “Setup”, and let the Setup Wizard guide the installation process.

## Startup

Below is an illustration of the “Startup” screen that will appear when the WinConfig program is invoked. Make certain that Nova-Flow is powered up before attempting to establish communications. Connection may be made to the Nova-Flow via cable or the infrared interface. Click on “Communications” then on “Initialize” and select the appropriate Com port designation and Com port type. After making the appropriate selections, click on “OK” and verify that the COMM Window in the bottom right corner of the screen displays “OK”.

After establishing Communications, the Startup screen will display the detected Unit Type, software version, and the electronic serial number assigned to the flow computer.

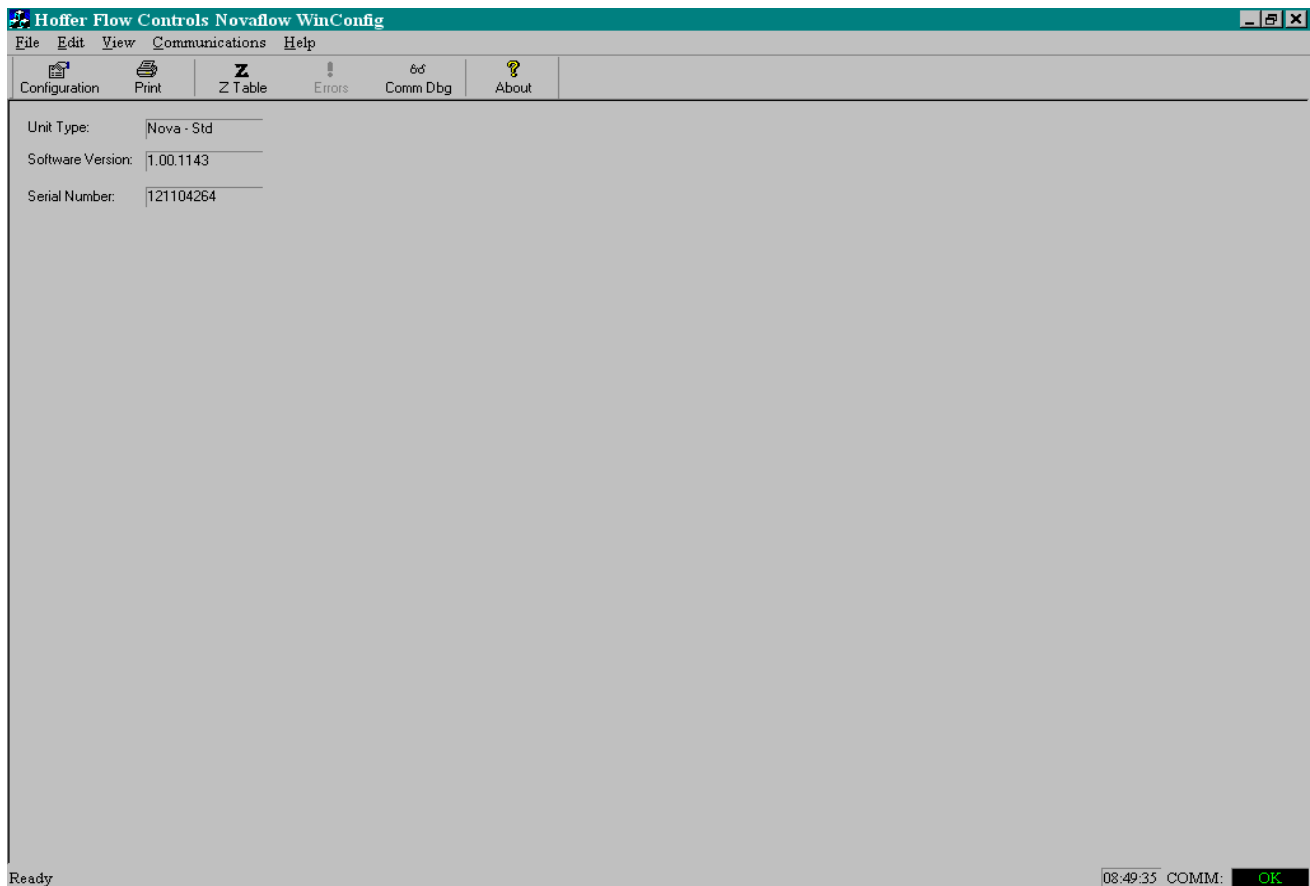

**Print**

Clicking on “Print” in the Startup screen will print a copy of the programmed configuration parameters to a printer connected to the personal computer. A preview of the printout can be displayed by selecting “File” and then “Print Preview”.

**Z-Table**

When performing gas calculations, a Z-Table may be used to determine the compressibility of the gas over operating temperature and pressure ranges. Clicking on “Z-Table” in the Startup screen will upload the current Z-Table from Nova-Flow. Data files can be opened by selecting “Load File”, selecting the proper drive and directory, and selecting the desired .DAT file. Selecting “Download” will write the Z-Table to Nova-Flow.

Temp(F)	150	160	170	180	190	200	210	220	230	240	250	260	270
32	0.99501	0.99469	0.99438	0.99407	0.99376	0.99346	0.99316	0.99286	0.99256	0.99226	0.99197	0.99168	0.99140
42	0.99575	0.99549	0.99522	0.99496	0.99470	0.99445	0.99419	0.99394	0.99369	0.99345	0.99320	0.99296	0.99272
52	0.99644	0.99622	0.99600	0.99579	0.99557	0.99536	0.99515	0.99495	0.99474	0.99454	0.99434	0.99414	0.99395
62	0.99708	0.99690	0.99673	0.99655	0.99638	0.99621	0.99604	0.99587	0.99571	0.99555	0.99539	0.99523	0.99508
72	0.99767	0.99753	0.99739	0.99726	0.99712	0.99699	0.99686	0.99673	0.99661	0.99648	0.99636	0.99624	0.99612
82	0.99822	0.99811	0.99801	0.99791	0.99781	0.99771	0.99762	0.99753	0.99744	0.99735	0.99726	0.99717	0.99709
92	0.99872	0.99865	0.99858	0.99852	0.99845	0.99838	0.99832	0.99826	0.99820	0.99815	0.99809	0.99804	0.99799
102	0.99919	0.99915	0.99911	0.99908	0.99904	0.99901	0.99897	0.99894	0.99892	0.99889	0.99886	0.99884	0.99882
112	0.99963	0.99962	0.99961	0.99960	0.99959	0.99958	0.99958	0.99958	0.99958	0.99958	0.99958	0.99958	0.99959
122	1.00004	1.00005	1.00006	1.00008	1.00010	1.00011	1.00014	1.00016	1.00018	1.00022	1.00024	1.00027	1.00030
132	1.00041	1.00045	1.00049	1.00052	1.00057	1.00062	1.00066	1.00071	1.00076	1.00081	1.00086	1.00091	1.00096
142	1.00076	1.00082	1.00089	1.00095	1.00101	1.00108	1.00115	1.00122	1.00129	1.00136	1.00143	1.00150	1.00159
152	1.00109	1.00116	1.00125	1.00133	1.00142	1.00150	1.00160	1.00169	1.00177	1.00187	1.00197	1.00206	1.00216
162	1.00139	1.00149	1.00160	1.00170	1.00181	1.00191	1.00201	1.00213	1.00224	1.00235	1.00245	1.00258	1.00269
172	1.00167	1.00179	1.00191	1.00204	1.00216	1.00228	1.00241	1.00254	1.00267	1.00279	1.00293	1.00306	1.00319

Figure 2. Z-Table Screen.

## Configuration

After communications have been established, clicking on “Configuration” uploads program information from Nova-Flow. Once the upload is complete, the I/O menu will be displayed. Other available menu items may be selected by clicking on the appropriate tabs at the top of the screen.

### I/O Configuration Menu

The I/O Configuration Menu is used to configure Main board I/O options as well as assigning, configuring and calibrating optional I/O modules. Diagnostic functions for specific I/O options are also available in the I/O Menu.

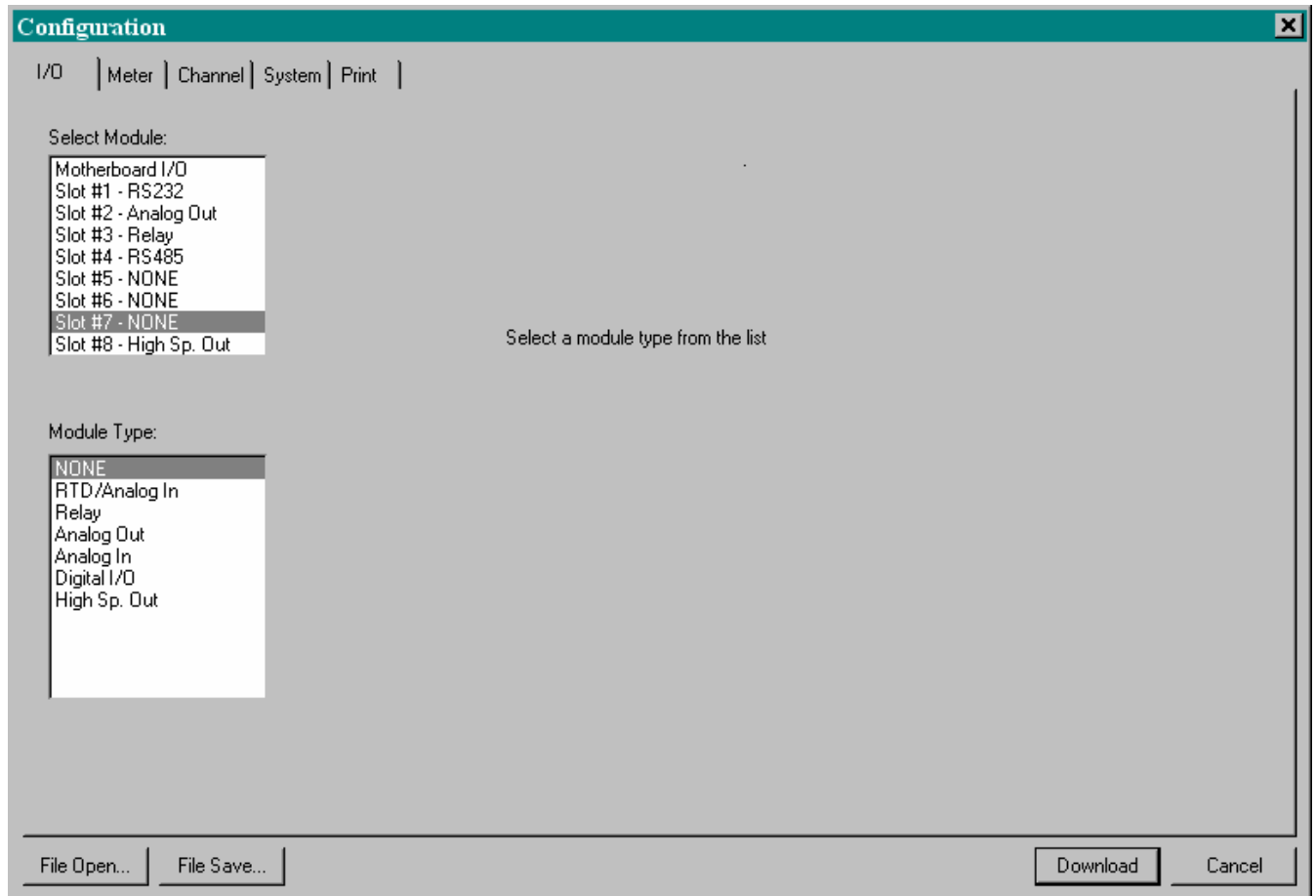

Figure 3. I/O Configuration Menu.

### Meter Configuration Menu

The Meter Configuration Menu is used to configure all parameters associated with connected flow meter(s). The A, B, C, and D buttons on the left side of the screen represent the channel designations. Selecting one of these buttons will display the Meter options for the associated channel.

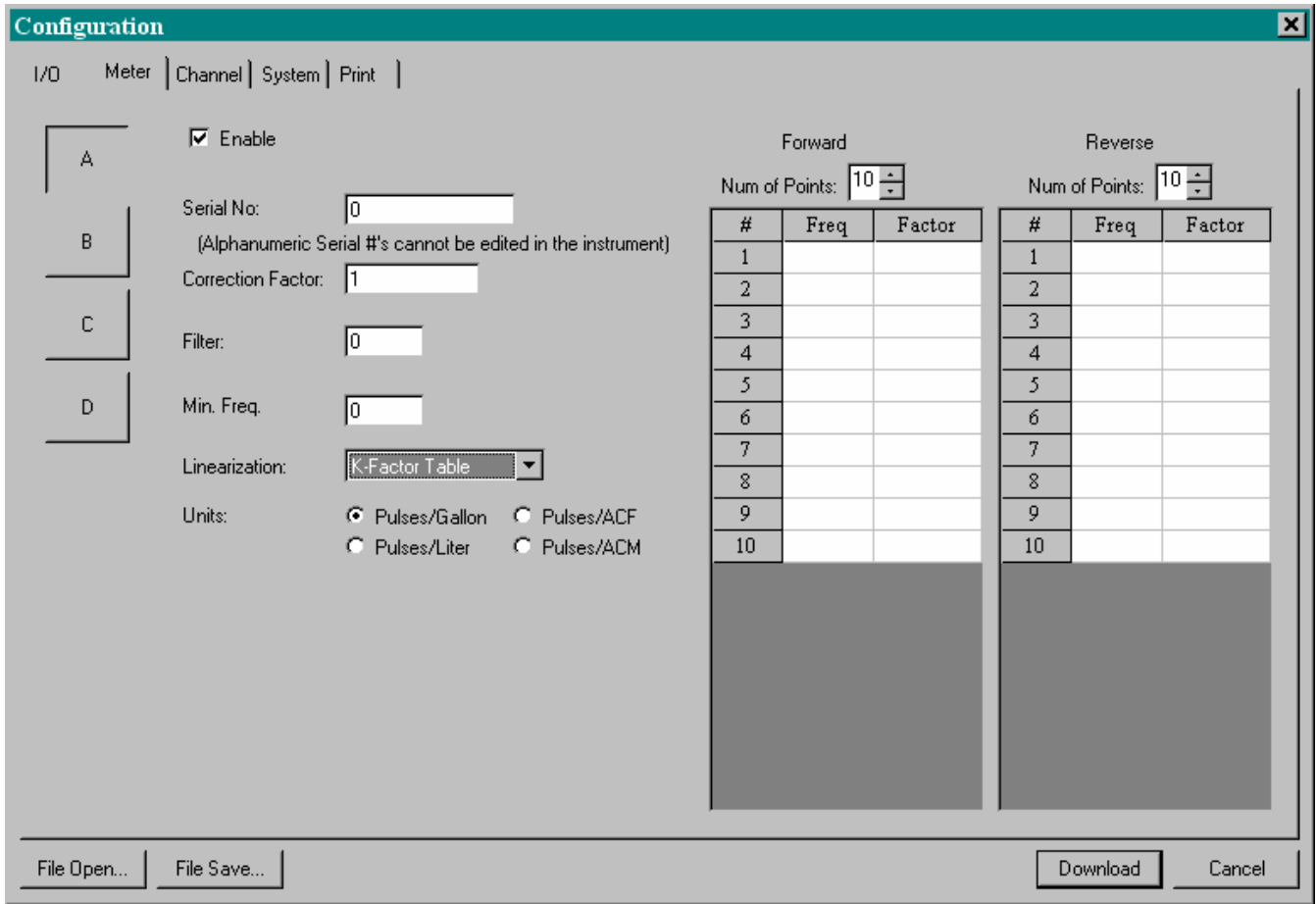

Figure 4. Meter Configuration Menu.

## Channel Configuration Menu

The Channel Configuration Menu is used to configure metrological specifics such as the calculation and compensation methods, default conditions, and unit selections for each channel. The A, B, C, and D buttons on the left side of the screen represent the channel designations. Selecting one of these buttons will display the options for the associated channel.

The screenshot shows the 'Configuration' window with the following settings:

- Channel Selection:** Buttons A, B, C, and D are visible on the left.
- Calculation Method:** Liquid Mass
- Compensation Method:** Temp
- Fluid:** Fluid 1
- Default Conditions:**
  - Temp: 70
  - Press: 150
  - Dens: 6.575
- Units:**
  - English Custom (selected)
  - Metric Default
  - Metric Custom
- Unit Selections:**
  - Total: Gallon
  - Rate: Gallon / Min
  - Temp: Fahrenheit
  - Pressure: Pound/sq inch absolul
  - Density: Pound/gallon
  - Mass: Pounds
- Buttons:** File Open..., File Save..., Download, Cancel

Figure 5. Channel Configuration Menu.

### System Configuration Menu

The System Configuration Menu provides four lower level menus as follows:

Utility Functions: Program the Menu timeout feature, Enable/Disable the keypad, Configure Math Functions.

Password/Pin: Program two levels of password protection for up to ten users.

Fluid Properties: Provides configuration parameters for up to four different fluids.

Base Conditions: Select the appropriate operating conditions.

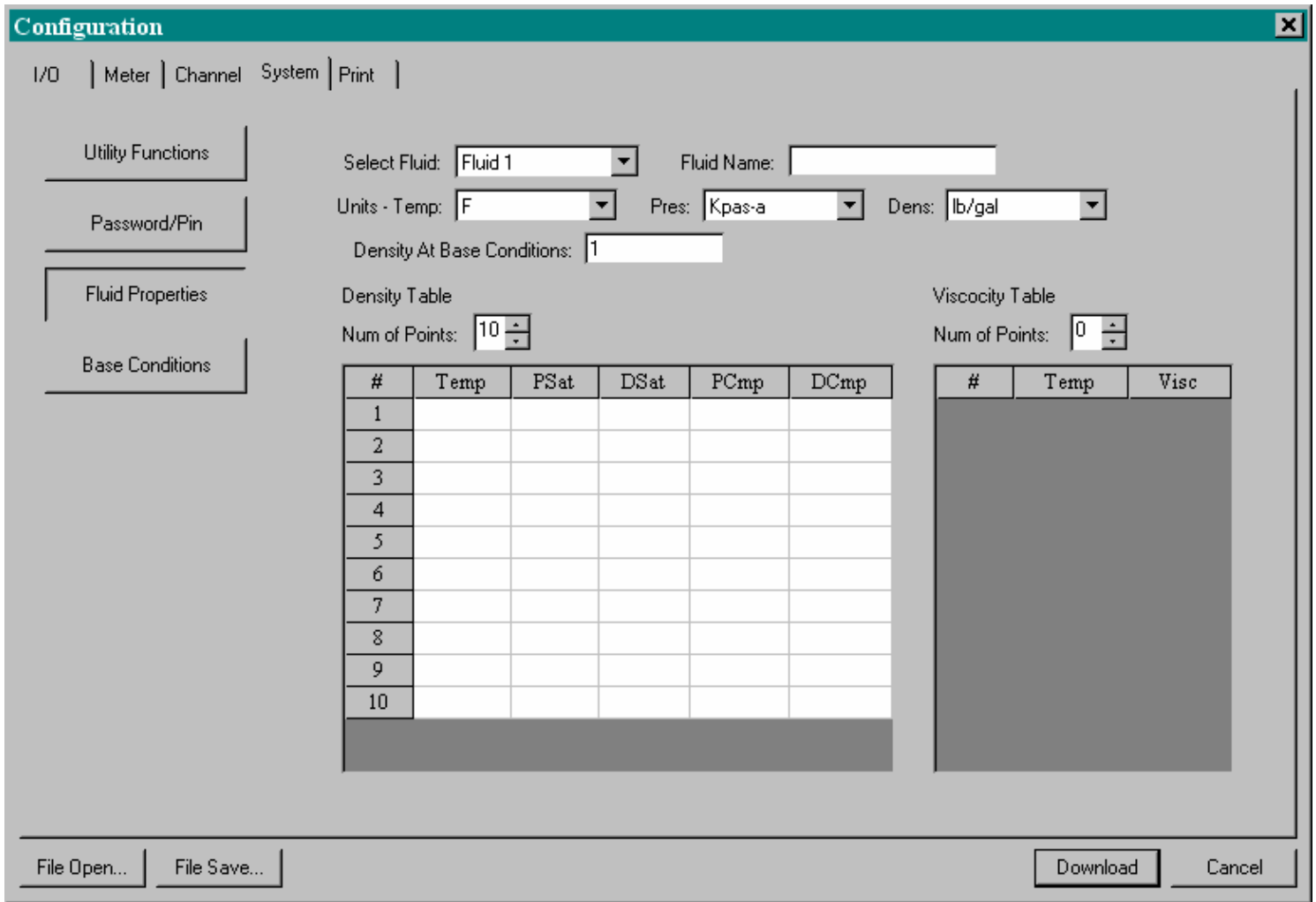

Figure 6. System Configuration Menu (Fluid Properties Shown).

## Print Menu

The Print Menu is used to select the printer that is connected to the Nova-Flow and define the associated column width. A list of variables is also provided to select specific process parameters for printing when Print Variables is selected on the Nova-Flow. The selected variables may be printed automatically at programmed intervals by entering a value corresponding to the print interval in minutes in the Print Frequency field.

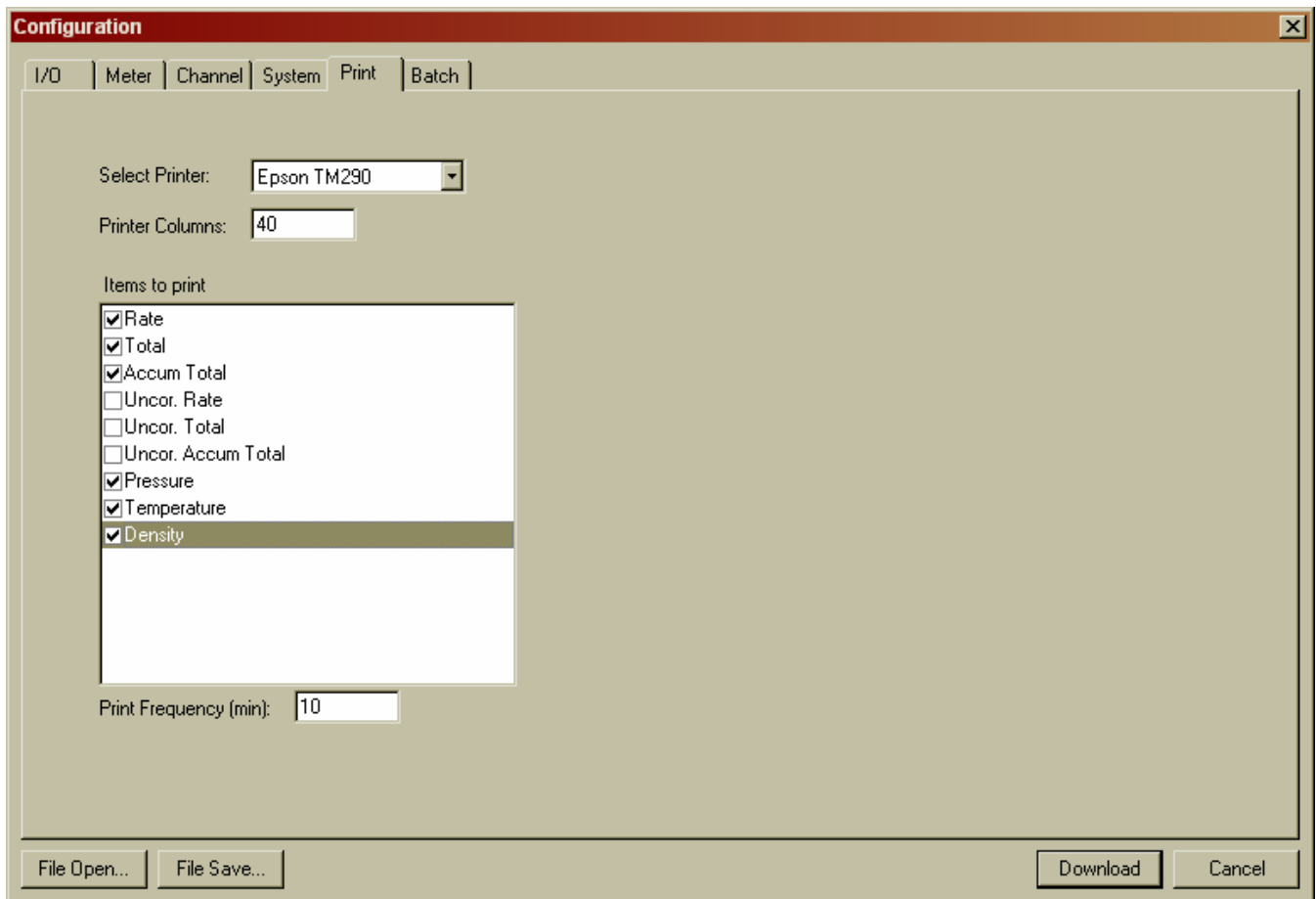

Figure 7. Print Menu.

### Downloading the Configuration

When all required parameters have been programmed, the configuration may be downloaded to the Nova-Flow by clicking on the “Download” button located in the bottom right corner of the configuration screens. After the configuration has been downloaded, a software reset is required on the Nova-Flow for the new configuration to take affect.

### Configuration Files

WinConfig allows configurations to be saved as a file for future use. The two available file functions are File Open and File Save which are described below.

### Saving Configuration Files

After all required parameters have been programmed, click on the “File Save” button located in the bottom left corner of the configuration screens. When the “Save As” window appears, select the destination drive and directory, provide a name for the file and click on “Save”. All configuration files are given an .HFC extension.

### Opening Configuration Files

To recall previous configurations, click on the “File Open” button located in the bottom left corner of the configuration screens. When the “Open” window appears, select the proper drive and directory, select the desired .HFC file, then click on “Open”.

### Offline Editing

Configuration files may be created offline for future downloads. Click on “Configuration” in the Startup screen and a “Device Offline” message box will appear. Select the device type from the provided list and click on “OK”. WinConfig will then enter the configuration mode. Configure all necessary parameters and then save the configuration as a file using the previously described method.

### NOTE

When editing offline, attempts to download will result in the configuration being lost. Be sure to save the configuration as a file.

# Appendix A: Liquid Calculation Flow Chart

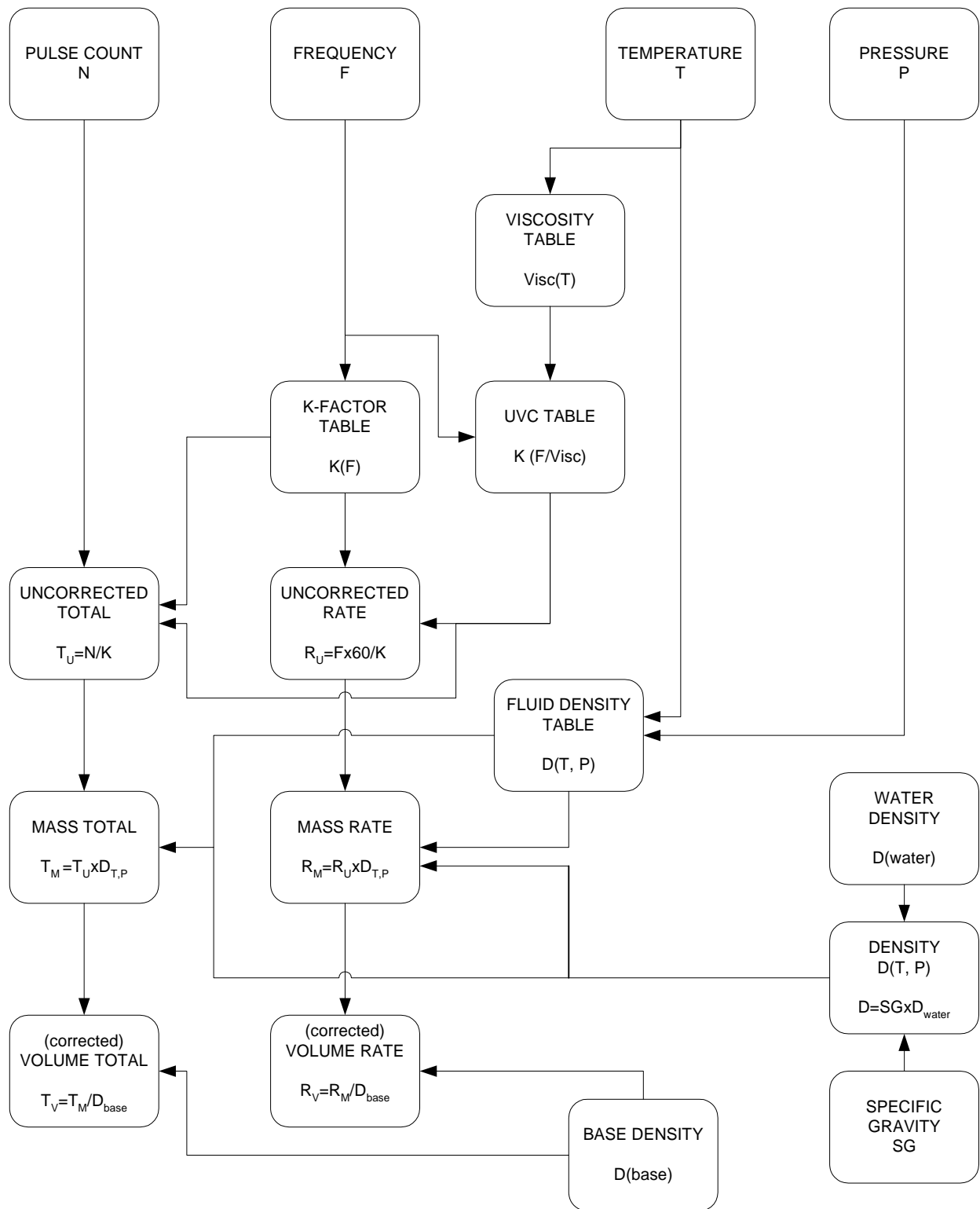

# Appendix B: Gas Calculation Flow Chart

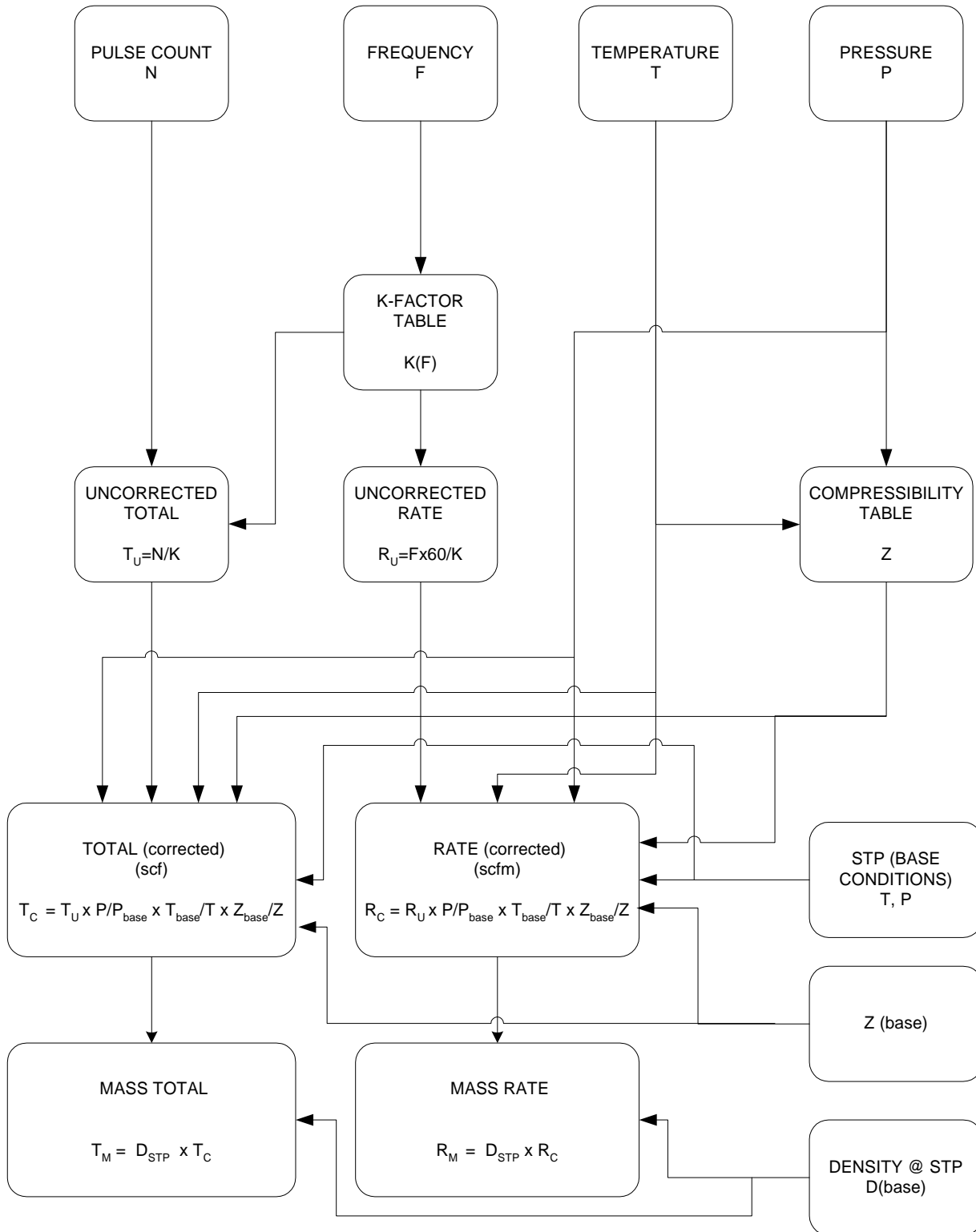

# Appendix C: Units of Measure

---

## Liquid Volume

Full Name	Abbr. Name	Multiplier
Gallons	GAL	1
Liter	L	3.785411784
Milliliter	ML	3785.411784
Cubic feet	FT3	0.133680556
Pint	PT	8
Fluid ounce	FLOZ	128
Barrel (oil)	BBL	0.02380952381
Cubic meter	M3	0.003785412
Cubic centimeter	CC	3785.411784
Quart	QT	4
Imperial gallon	IGAL	0.832674

## Gas Volume

Full Name	Abbr. Name	Multiplier
Actual cubic feet	ACF	0.133680556
Actual liters	AL	3.785411784
Actual cubic centimeters	ACC	3785.411784
Actual cubic meters	ACM	0.003785412
Million cubic feet	MCF	133680.5556

## Gas Mass

Full Name	Abbr. Name	Multiplier
Kilograms	KG	0.45359237
Pounds	LB	1
Gram	G	453.59237

## Liquid Mass

Full Name	Abbr. Name	Multiplier
Pounds	LB	1
Kilograms	KG	0.45359237
Once	OZ	16
Ton	TON	0.0005
Metric ton	MTON	.00045
Gram	G	453.59237

**Temperature**

Full Name	Abbr. Name	Multiplier	Offset
Fahrenheit	F	1	0
Celsius	C	0.555555556	-32.00
Kelvin	K	0.555555556	+459.67
Rankine	R	1	+459.67

**Pressure**

Full Name	Abbr. Name	Multiplier	Offset
Pound/sq inch absolute	PSIA	1	0
Atmosphere	ATM	0.068045964	0
Pound/sq inch gauge	PSIG	1	-14.69595
Bar gauge	BAR-G	0.068947573	-0.944302
Bar absolute	BAR-A	0.068947573	0
Kilo Pascal gauge	KPA-G	6.894757293	-94.43024
Kilo Pascal absolute	KPA-A	6.894757293	0
Mega Pascal gauge	MPA-G	0.006894757	-0.09443
Mega Pascal absolute	MPA-A	0.006894757	0
KG/CM2-G	KG/CM2-G	0.070306958	-0.96292
KG/CM2-A	KG/CM2-A	0.070306958	0
Millimeter of water column	MM W.C.		
Inch of water column	IN W.C.	27.7075924	0
Millimeter of mercury	MM HG	51.71493257	0
Inch of mercury	IN HG	2.036020967	0

**Density**

Full Name	Abbr. Name	Multiplier
Pound/gallon	LB/GAL	1
Kilogram/liter	KG/L	0.119826427
Pound/cubic feet	LB/FT3	7.480519481
Kilogram/cubic meter	KG/M3	119.8264273

**K-factor**

Full Name	Abbr. Name	Multiplier
Pulse/gallon	PULSE/GALLON	1
Pulse/liter	PULSE/LITER	0.264172052
Pulse/ft3	PULSE/FT3	7.480519481
Pulse/m3	PULSE/M3	264.1720524

**Meter Factor**

<b>Full Name</b>	<b>Abbr. Name</b>	<b>Multiplier</b>
Gallon/pulse	GAL/PULS	1
Cubic meter/pulse	M3/PULS	0.003785412

**Energy**

<b>Full Name</b>	<b>Abbr. Name</b>	<b>Multiplier</b>
Kilo BTU	KBTU	1
Kilowatt-hour	KWH	0.293071111
Megawatt hour	MWH	0.000293071
Mega Joule	MJ	1.055056
Giga Joule	GJ	0.001055056
Horsepower hour US	HP US	0.393014834
Calorie		251995.7963

**Power**

<b>Full Name</b>	<b>Abbr. Name</b>	<b>Multiplier</b>
Energy unit/hour	KBTU/HR	1
	KW	0.293071111

**Time**

<b>Full Name</b>	<b>Abbr. Name</b>	<b>Multiplier</b>
Second	SEC	1
Minute	MIN	
Hour	HR	
Day	DAY	

**Corrected Volume (Gas and Liquid)**

<b>Full Name</b>	<b>Abbr. Name</b>	<b>Multiplier</b>
Standard cubic feet	SCF	equation
Normal cubic meter	NCM	equation
Standard cubic meter	SCM	equation

# Appendix D: Error Messages

---

	<i>MESSAGE</i>	<i>DESCRIPTION</i>
1	CHX HIGH FLOW ALARM	Flow Rate has exceeded the limit defined for the High Flow Alarm parameter of the Digital I/O or Relay Flow Alarm output.
2	CHX LOW FLOW ALARM	Flow Rate has fallen below the limit defined for the Low Flow Alarm parameter of the Digital I/O or Relay Flow Alarm output
3	CHX HIGH FLOW WARNING	Flow Rate has exceeded the limit defined in the High Warning parameter of the Digital I/O or Relay Flow Alarm output
4	CHX LOW FLOW WARNING	Flow Rate has fallen below the limit defined in the Low Warning parameter of the Digital I/O or Relay Flow Alarm output
5	CHX HIGH TEMP ALARM	Temperature has exceeded the limit defined for the High Alarm parameter of the Digital I/O or Relay Temp Alarm output.
6	CHX LOW TEMP ALARM	Temperature has fallen below the limit defined for the Low Alarm parameter of the Digital I/O or Relay Temp Alarm output.
7	CHX HIGH TEMP WARNING	Temperature has exceeded the limit defined for the High Warning parameter of the Digital I/O or Relay Temp Alarm output
8	CHX LOW TEMP WARNING	Temperature has fallen below the limit defined for the Low Warning parameter of the Digital I/O or Relay Flow Alarm output.
9	CHX HIGH PRES ALARM	Pressure has exceeded the limit defined for the High Alarm parameter of the Digital I/O or Relay Pres Alarm output
10	CHX LOW PRES ALARM	Pressure has fallen below the limit defined for the Low Alarm parameter of the Digital I/O or Relay Pressure Alarm output.

**Appendix D: Error Messages**

	<i>MESSAGE</i>	<i>DESCRIPTION</i>
11	CHX HIGH PRES WARNING	Pressure has exceeded the limit defined for the High Warning parameter of the Digital I/O or Relay Pressure Alarm output.
12	CHX LOW PRES WARNING	Pressure has fallen below the limit defined for the Low Warning parameter of the Digital I/O or Relay Pressure Alarm output.
13	CHX HIGH DENSITY ALARM	Density has exceeded the limit defined for the High Alarm parameter of the Digital I/O or Relay Density Alarm output
14	CHX LOW DENSITY ALARM	Density has fallen below the limit defined for the Low Alarm parameter of the Digital I/O or Relay Density Alarm output
15	CHX HIGH DENSITY WARNING	Density has exceeded the limit defined for the High Warning parameter of the Digital I/O or Relay Density Alarm output
16	CHX LOW DENSITY WARNING	Density has fallen below the limit defined for the Low Warning parameter of the Digital I/O or Relay Density Alarm output.
17	CHX HIGH SPECIFIC GRAVITY ALARM	Specific Gravity has exceeded the limit defined for the High Alarm parameter of the Digital I/O or Relay Sp. Gravity Alarm output.
18	CHX LOW SPECIFIC GRAVITY ALARM	Specific Gravity has fallen below the limit defined for the Low Alarm parameter of the Digital I/O or Relay Sp. Gravity Alarm output.
19	CHX HIGH SPECIFIC GRAVITY WARNING	Specific Gravity has exceeded the limit defined for the High Warning parameter of the Digital I/O or Relay Sp. Gravity Alarm output
20	CHX LOW SPECIFIC GRAVITY WARNING	Specific Gravity has fallen below the limit defined for the Low Warning parameter of the Digital I/O or Relay Sp. Gravity Alarm output.
21	CHX RTD PROBE SHORT	Temperature probe resistance input is less than 5 OHMS.
22	CHX RTD PROBE OPEN	Temperature probe resistance input is more than 15K OHMS resistance
23	CHX PRESS FAIL	Pressure Analog signal input is not detected. The computed value of the analog input value of the selected channel is equal to zero volts.

**Appendix D: Error Messages**

	<i>MESSAGE</i>	<i>DESCRIPTION</i>
24	CHX TEMP FAIL	Temperature signal analog input is not detected. The computed value of the analog input value of the selected channel is equal to zero volts.
25	CHX TEMP COMP	Temperature of the selected channel is out of range specified for analog input
26	CHX PRES COMP	Pressure of the selected channel is out of range specified for analog input
27	PULSE FAILURE	Flow circuits detect a pulse failure in a dual coil application.
28	TWO PHASE WARNING	Pressure is between saturated pressure and 5 psia above the saturated pressure
29	GAS INHIBIT ON	Pressure is equal or below the saturated pressure.
30	FLOWMETER RUNNING	Displayed if the operator attempts to clear totals or make configuration changes while flow is present.