

Model: CAT3-DC-MIL
DC Powered Microprocessor
Controlled Transmitter
Style 3 Enclosure

USER'S MANUAL



HP-324-3
December 2018

HOFFER
Flow Controls

Perfecting Measurement™

107 Kitty Hawk Lane • P.O. Box 2145 • Elizabeth City, NC 27909
1-800-628-4584 • (252) 331-1997 • Fax (252) 331-2886
www.hofferflow.com email: info@hofferflow.com

NOTICE

HOFFER FLOW CONTROLS, INC. makes no warranty of any kind with regard to this material, including, but not limited to, the implied warranties of merchantability and fitness for a particular purpose.

This manual has been provided as an aid in installing, connecting, calibrating, operating, and servicing this unit. Every precaution for accuracy has been taken in the preparation of this manual; however, HOFFER FLOW CONTROLS, INC. neither assumes responsibility for any omissions or errors that may appear nor assumes liability for any damages that may result from the use of the products in accordance with information contained in the manual.

HOFFER FLOW CONTROLS' policy is to provide a user manual for each item supplied. Therefore, all applicable user manuals should be examined before attempting to install or otherwise connect a number of related subsystems.

During installation, care must be taken to select the correct interconnecting wiring drawing. The choice of an incorrect connection drawing may result in damage to the system and/or one of the components.

Please review the complete model number of each item to be connected and locate the appropriate manual(s) and/or drawing(s). Identify all model numbers exactly before making any connections. A number of options and accessories may be added to the main instrument, which are not shown on the basic user wiring. Consult the appropriate option or accessory user manual before connecting it to the system. In many cases, a system wiring drawing is available and may be requested from HOFFER FLOW CONTROLS.

This document contains proprietary information, which is protected by copyright. All rights are reserved. No part of this document may be photocopied, reproduced, or translated to another language without the prior written consent of HOFFER FLOW CONTROLS, INC.

HOFFER FLOW CONTROLS' policy is to make running changes, not model changes, whenever an improvement is possible. This affords our customers the latest in technology and engineering. The information contained in this document is subject to change without notice.

Return Requests / Inquiries

Direct all warranty and repair requests/inquiries to the Hoffer Flow Controls Customer Service Department, telephone number (252) 331-1997 or 1-800-628-4584. BEFORE RETURNING ANY PRODUCT(S) TO HOFFER FLOW CONTROLS, PURCHASER MUST OBTAIN A RETURNED MATERIAL AUTHORIZATION (RMA) NUMBER FROM HOFFER FLOW CONTROLS' CUSTOMER SERVICE DEPARTMENT (IN ORDER TO AVOID PROCESSING DELAYS). The assigned RMA number should then be marked on the outside of the return package and on any correspondence.

FOR **WARRANTY** RETURNS, please have the following information available BEFORE contacting HOFFER FLOW CONTROLS:

1. P.O. number under which the product was PURCHASED,
2. Model and serial number of the product under warranty, and
3. Repair instructions and/or specific problems relative to the product.

FOR **NON-WARRANTY** REPAIRS OR CALIBRATIONS, consult HOFFER FLOW CONTROLS for current repair/ calibration charges. Have the following information available BEFORE contacting HOFFER FLOW CONTROLS:

1. P.O. number to cover the COST of the repair/calibration,
2. Model and serial number of the product and
3. Repair instructions and/or specific problems relative to the product.

LIMITED WARRANTY

HOFFER FLOW CONTROLS, INC. ("HFC") warrants HFC's products ("goods") described in the specifications incorporated in this manual to be free from defects in material and workmanship under normal use and service, but only if such goods have been properly selected for the service intended, properly installed and properly operated and maintained. This warranty shall extend for a period of one (1) year from the date of delivery to the original purchaser (or eighteen (18) months if the delivery to the original purchaser occurred outside the continental United States). This warranty is extended only to the original purchaser ("Purchaser"). *Purchaser's sole and exclusive remedy is the repair and/or replacement of nonconforming goods as provided in the following paragraphs.*

In the event Purchaser believes the goods are defective, the goods must be returned to HFC, transportation prepaid by Purchaser, within twelve (12) months after delivery of goods (or eighteen (18) months for goods delivered outside the continental United States) for inspection by HFC. If HFC's inspection determines that the workmanship or materials are defective, the goods will be either repaired or replaced, at HFC's sole determination, free of additional charge, and the goods will be returned, transportation paid by HFC, using the lowest cost transportation available.

Prior to returning the goods to HFC, Purchaser must obtain a Returned Material Authorization (RMA) Number from HFC's Customer Service Department within 30 days after discovery of a purported breach of warranty, but no later than the warranty period; otherwise, such claims shall be deemed waived. See the Return Requests/Inquiries Section of this manual.

If HFC's inspection reveals the goods are free of defects in material and workmanship or such inspection reveals the goods were improperly used, improperly installed, and/or improperly selected for service intended, HFC will notify the purchaser in writing and will deliver the goods back to Purchaser upon (i) receipt of Purchaser's written instructions and (ii) the cost of transportation. If Purchaser does not respond within thirty (30) days after notice from HFC, the goods will be disposed of in HFC's discretion.

HFC does not warrant these goods to meet the requirements of any safety code of any state, municipality, or other jurisdiction, and Purchaser assumes all risk and liability whatsoever resulting from the use thereof, whether used singly or in combination with other machines or apparatus.

This warranty shall not apply to any HFC goods or parts thereof, which have been repaired outside HFC's factory or altered in any way, or have been subject to misuse, negligence, or accident, or have not been operated in accordance with HFC's printed instructions or have been operated under conditions more severe than, or otherwise exceeding, those set forth in the specifications for such goods.

THIS WARRANTY IS EXPRESSLY IN LIEU OF ALL OTHER WARRANTIES, EXPRESSED OR IMPLIED, INCLUDING ANY IMPLIED WARRANTY OF MERCHANTABILITY OR FITNESS FOR A PARTICULAR PURPOSE. HFC SHALL NOT BE LIABLE FOR ANY LOSS OR DAMAGE RESULTING, DIRECTLY OR INDIRECTLY, FROM THE USE OR LOSS OF USE OF THE GOODS. WITHOUT LIMITING THE GENERALITY OF THE FOREGOING, THIS EXCLUSION FROM LIABILITY EMBRACES THE PURCHASER'S EXPENSES FOR DOWNTIME OR FOR MAKING UP DOWNTIME, DAMAGES FOR WHICH THE PURCHASER MAY BE LIABLE TO OTHER PERSONS, DAMAGES TO PROPERTY, AND INJURY TO OR DEATH OF ANY PERSONS. HFC NEITHER ASSUMES NOR AUTHORIZES ANY PERSON TO ASSUME FOR IT ANY OTHER LIABILITY IN CONNECTION WITH THE SALE OR USE OF HFC'S GOODS, AND THERE ARE NO ORAL AGREEMENTS OR WARRANTIES COLLATERAL TO OR AFFECTING THE AGREEMENT. *PURCHASER'S SOLE AND EXCLUSIVE REMEDY IS THE REPAIR AND/OR REPLACEMENT OF NONCONFORMING GOODS AS PROVIDED IN THE PRECEDING PARAGRAPHS. HFC SHALL NOT BE LIABLE FOR ANY OTHER DAMAGES WHATSOEVER INCLUDING INDIRECT, INCIDENTAL, OR CONSEQUENTIAL DAMAGES.*

FORWARD

The manual contains the information required to install, operate, maintain, and repair a CAT3-DC-MIL Flow Rate Signal Converter.

The CAT3-DC-MIL unit is intended to provide ships personnel with the ability to monitor flow of fuel and other liquids.

This page intentionally left blank.

CONTENTS

FORWARD -----	i
CONTENTS-----	iii
1. Safety -----	1
2. Compliance-----	3
3. Specifications-----	5
3-1 Model Number Designation-----	6
4. Operation -----	7
4-1 Flowmeter Input -----	7
4-2 Microcontroller -----	8
4-3 Analog Output -----	8
4-4 Pulse Output-----	10
4-5 Communications Interface -----	11
5. Installation-----	13
5-1 Wiring-----	13
6. Preventative Maintenance-----	15
6-1 Introduction -----	15
6-2 Unit Removal -----	15
7. Troubleshooting -----	19
7-1 Introduction -----	19
7-2 Flow Sensor Troubleshooting Procedures -----	19
Appendix A – Default Configuration -----	21
Appendix B - Communications-----	23
Communications Interface -----	23
Appendix C – Drawing-----	24

This page intentionally left blank.

1. SAFETY

The CAT3-DC-MIL Fuel Metering unit is designed to satisfy the safety requirements for shipboard use.

The safety precautions and warnings described here are to be observed at all times. Additional precautionary messages appear throughout this manual.

This page intentionally left blank.

2. COMPLIANCE

This instrument is designed to conform to the EMC-Directive of the Council of European Communities 89/336/EEC.

4 Compliance

This page intentionally left blank.

3. SPECIFICATIONS

Input Signal Type:	Magnetic pick up
Input frequency range:	0.2 Hz to 4 KHz
Signal level:	10 mV rms to 30 Vdc
Power supply:	13-30 VDC
Analog Output:	4-20mA, 24mA overflow condition
Analog Output Response Time:	1/8 sec.*
Load resistance:	Max 650 Ohms at 24 Vdc
Accuracy:	+/- 0.02% of full scale @ 20° C
Temperature drift:	40ppm/deg C
Pulse output	0-5, 0-10V, Open Collector, AC square Internal pull-up resistor 10k Ohms Recommended load min. 50k Ohms
Maximum Pulse Frequency	1, 2, 4, 8, 100, 50% Duty Cycle
Pulse Scaling	Per flow unit of measure, divide by 1, 10, 100 100 Hz max frequency
Communications	RS232 port for Configuration and diagnostics
Operating temperature:	-40 to 85 C°
Humidity:	0-90% Non-condensing
Enclosure:	Extruded aluminum housed in Style 3 enclosure (NEMA 4) and Explosion Proof
Regulatory:	CE compliant
Linearization:	20 point

*Limited by signal frequency and MST settings. Refer to Section 4-3.

6 Specifications

3-1 Model Number Designation

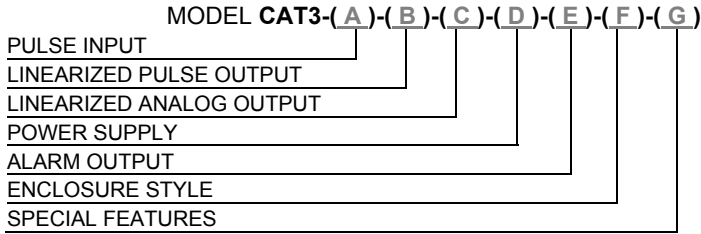

PULSE INPUT

MODEL CAT3-(A)-()-()-()-()-()-()

OPTION (A)

(1) MAG COIL, PULSE, DRY CONTACT

LINEARIZED PULSE OUTPUT

MODEL CAT3-()-(B)-()-()-()-()-()

OPTION (B)

(4) AC SQUARE WAVE

LINEARIZED ANALOG OUTPUT

MODEL CAT3-()-()-(C)-()-()-()-()

OPTION (C)

(1) 4-20 MA

POWER SUPPLY

MODEL CAT3-MIL-()-()-()-(D)-()-()-()

OPTION (D)

(DC) 13-30 VDC

ALARM OUTPUT

MODEL CAT3-()-()-()-()-(E)-()-()

OPTION (E)

(X) NONE

ENCLOSURE STYLE

MODEL CAT3-()-()-()-()-()-(F)-()

OPTIONS (F)

(3) STYLE 3 ENCLOSURE, NEMA 4 AND EXPLOSION PROOF

SPECIAL FEATURES

MODEL CAT3-()-()-()-()-()-()-(G)

OPTIONS (G)

(MIL) DESIGNED TO MEET EMC STDS EN5011-1992 AND EN61326-1:1997

4. OPERATION

The CAT3-DC-MIL is a DC powered microprocessor-based transmitter, which provides pulse and analog outputs. The flowmeter input circuitry will accept a magnetic type pickup, pulse and contact closure. Optional 20-point linearization is available to correct for flowmeter non-linearity, improving overall system accuracy.

CAT3-DC-MIL Block Diagram

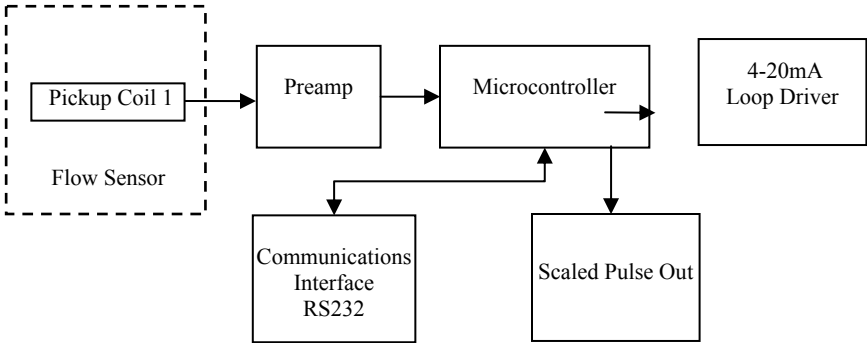

4-1 Flowmeter Input

The Preamp circuitry for conditioning the flow signal is located on PCA180. The following drawings illustrate typical connections and switch settings on PCA180 for various input signals.

Magnetic Pickup Coil

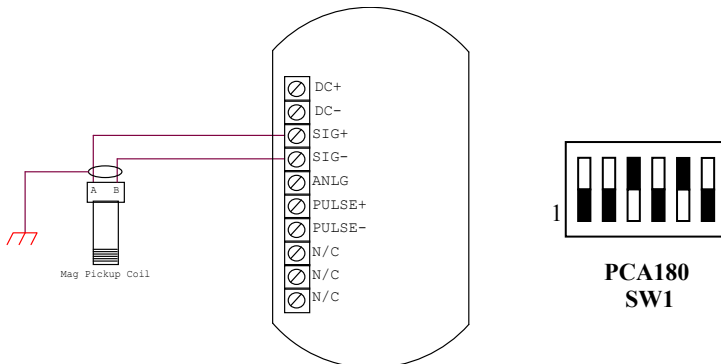

8 Operation

4-2 Microcontroller

The Microcontroller performs all of the calculations that are required to control the analog output and pulse output. The following equations are used to calculate the flowrate and the analog output current.

$$\text{Flowrate} = \text{frequency}/\text{K-factor} \times 60$$

Where:

K-factor = Is the flow meter calibration factor in pulses/gal

Flowrate is in gal/min.

Frequency is in Hertz.

4-3 Analog Output

CAT3-DC-MIL provides an Analog Output option that will output an analog current or voltage that is proportional to the flow rate.

Analog Output

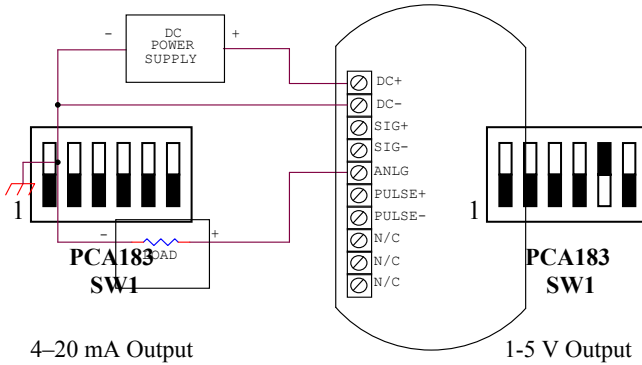

The Microcontroller, located on PCA183, accepts the square-wave output of the preamplifier and performs all of the calculations that are required to control the Loop Driver. After measuring the frequency of the square-wave, the Microcontroller uses the following equations to compute the flow rate and current.

$$\text{flowrate} = \frac{\text{frequency}}{\text{Kfactor}} \times 60^{FM} \times CF$$

Where:

- Kfactor = Is dependent on the Flow Calculation Method setting and is either the Average K-Factor or the Linearized K-Factor from the Frequency / K-Factor table.
- FM = Is the Flow rate Units setting of 0, 1, or 2. Where “0” is for Seconds, “1” is for Minutes, and “2” is for Hours.
- CF = Is the Correction Factor setting.

$$\text{current} = 4mA + \left(16mA \times \frac{\text{flowrate}}{AF} \right)$$

Where:

- AF = Is the 20 mA maximum Flow rate value.

If the calculated flowrate is greater than the AF setting, the current will be set to 24mA to indicate an “Over-range” condition. After calculating the current, the Microcontroller digitally sends the current information to the Loop Driver. The loop driver, located on PCA183, uses the digital information sent to it by the Microcontroller to set the current of the loop. The Loop Driver also supplies power to the Microcontroller.

The analog output response time to reach steady state due to a change in the flow rate is approximately 1/8 of a second. When flow stops, the time for the analog output to return to 4 mA will be between .25 and 8 seconds, depending on the Maximum Sample Time (MST) setting. MST is adjusted using the NB=(DATA) command, where NB is a value between 1 and 80. The default MST setting is NB= 1. Adjusting the MST is only recommended for low flow applications where the minimum input frequency is below 1 Hz.

10 Operation

4-4 Pulse Output

CAT3-DC-MIL provides a Pulse Output option that is scaled per flow unit of measure by a factor of 1, 10 or 100. Pulse output frequency varies with flow rate. The maximum frequency can be set at 1, 2, 4, 8, 100 Hz. The following drawings illustrate typical connections and switch settings for various pulse output options.

TTL(0-5V), 0-10V, High Level (DC In), AC Square

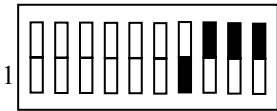
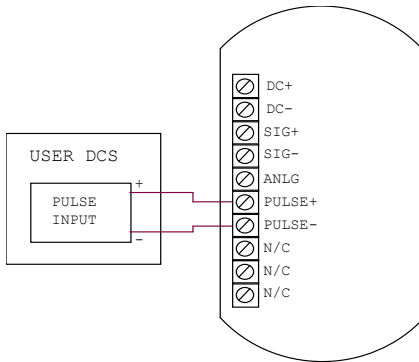

**PCA180
SW2**

TTL(0-5V), 0-10V, AC Square

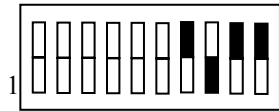

**PCA180
SW2**

High Level Pulse, AC Square

Open Collector, Isolated Pulse

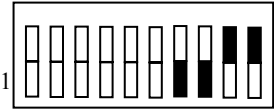
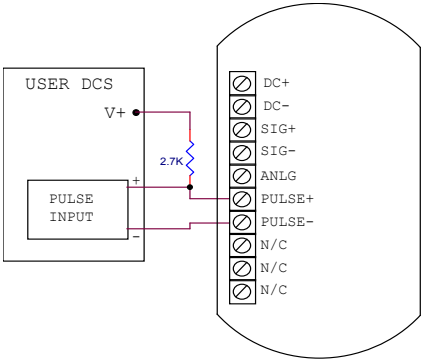

**PCA180
SW2**

Open Collector

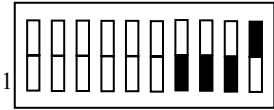

**PCA180
SW2**

Isolated Pulse

4-5 Communications Interface

An RS232 communications port located under the top plate allows CAT3-DC-MIL to be remotely configured and trouble-shoot using a Windows based program. Refer to the Appendix B section for communication details.

The communication function is available only when CAT3-DC-MIL device is powered.

This page intentionally left blank.

5. INSTALLATION

5-1 Wiring

When installing CAT3-DC-MIL, it is a good practice to use shielded cables for all input and output signals. The shield should be connected to the earth ground lug on the CAT3-DC-MIL. The shield on the opposite end of the cable should be left open.

This wiring practice is mandatory in order to comply with the requirements for Electromagnetic Compatibility, as per EMC-Directive 89/336/EEC of the Council of European Community.

This page intentionally left blank.

6. PREVENTATIVE MAINTENANCE

6-1 Introduction

Observe any scheduled organizational level maintenance instructions dictated by the requirements of the Planned Maintenance System (PMS) established by the Naval Sea System Command for fuel system components.

6-2 Unit Removal

1. Turn off the power supply.
2. Open the Style 3 enclosure and unplug the 10-pin terminal from the header.
3. Remove the top plate screw from the blue enclosure to disconnect ground wire.
4. Remove two mounting screws from the mounting plate on the bottom of the blue enclosure.
5. Remove the unit and install new one.
6. Replace all mounting screws.

This page intentionally left blank.

7. TROUBLESHOOTING

7-1 Introduction

The troubleshooting techniques in this chapter are designed to isolate and locate the area of failure and to present the procedures for the replacement of subassemblies to make the system operational.

7-2 Troubleshooting Procedures

The required test equipment for troubleshooting is as follows:

Digital Multimeter: Fluke Model 8060A or equal.

Identify one of the symptoms listed below and follow the procedure. In each case proceed to the next step only if the defect is not found.

7-2-1 Symptom: No flow indication when flow is present

1. Visually examine the interconnecting signal cable for broken or shorted leads.
2. With an established flowrate, configure the digital multimeter to measure AC volts, using the two volt scale. Measure voltage at the terminal, on Pin 3, SIG+ and Pin 4 SIG-. Depending on the flowrate, an approximate voltage reading of 10 millivolts to 1 volt should be measured. If voltage is present replace the electronic unit. If no voltage go to step 3.
3. Disconnect the signal cable from the electronics unit and from the flow sensor. Check the continuity of each lead of the cable. If defective replace or repair.
4. With the signal cable disconnected from the flow sensor measure the DC resistance of the pickup coil. The resistance should read between 1500 and 2200 ohms between pin A and pin B. A short or an open indicates a defective pickup coil and the pickup coil must be replaced.

20 Troubleshooting

5. With an established flowrate, configure the digital multimeter to measure AC volts, using the two volt scale. Connect the positive lead to pin A of pickup coil. And the negative lead to pin B of pickup coil. Depending on the flowrate an approximate voltage reading of 10 millivolts to 1 volt should be measured.
6. If zero volts are measured, a stalled rotor condition is indicated. Remove the flow sensor from the piping. Refer to flow sensor manual.

7-2-2 Symptom: Flow indication with no flow present

This symptom indicates the presence of electrical noise pickup.

1. Disconnect the signal cable from the electronics unit and from the flow sensor. Check the continuity of each lead of the cable. If defective replace or repair.
2. With the signal cable disconnected from the flow sensor measure the DC resistance of the pickup coil. The resistance should read between 1500 and 2200 ohms between pin A and pin B. A short or an open indicates a defective pickup coil and the pickup coil must be replaced.
3. Verify cable shield connection.
4. Verify electronics unit enclosure connection to ships ground.

Appendix A – Default Configuration

Factory default configuration:

<i>FIELD</i>	<i>Value</i>
TAG NUMBER	10000000
LINEARIZATION	Average
K FACTOR DECIMAL POINTS	3
AVERAGE K FACTOR	1.00
NUMBER OF LINEARIZATION POINTS	20
FREQUENCY 1	4999.981
FREQUENCY 2	4999.982
FREQUENCY 3	4999.983
FREQUENCY 4	4999.984
FREQUENCY 5	4999.985
FREQUENCY 6	4999.986
FREQUENCY 7	4999.987
FREQUENCY 8	4999.988
FREQUENCY 9	4999.989
FREQUENCY 10	4999.990
FREQUENCY 11	4999.991
FREQUENCY 12	4999.992
FREQUENCY 13	4999.993
FREQUENCY 14	4999.994
FREQUENCY 15	4999.995
FREQUENCY 16	4999.996
FREQUENCY 17	4999.997
FREQUENCY 18	4999.998
FREQUENCY 19	4999.999
FREQUENCY 20	5000.000
K FACTOR 1	1.00
K FACTOR 2	1.00
K FACTOR 3	1.00
K FACTOR 4	1.00
K FACTOR 5	1.00
K FACTOR 6	1.00
K FACTOR 7	1.00
K FACTOR 8	1.00
K FACTOR 9	1.00
K FACTOR 10	1.00
K FACTOR 11	1.00
K FACTOR 12	1.00
K FACTOR 13	1.00
K FACTOR 14	1.00
K FACTOR 15	1.00

22 Appendix A – Default Configuration

<i>FIELD</i>	<i>Value</i>
K FACTOR 16	1.00
K FACTOR 17	1.00
K FACTOR 18	1.00
K FACTOR 19	1.00
K FACTOR 20	1.00
CORRECTION FACTOR	1.000
TOTAL UNITS	GAL
RATE UNITS	MIN
MAX SAMPLE TIME	01
4 MA SETTING	00000.000
20 MA SETTING	99.999
PULSE SCALE	OFF
PULSE OUT FREQUENCY	8
ALARM FUNCTION	OFF
ALARM SETPOINT	99999.981
CURRENT MODE	RATE
TEST PULSE	NO
ALARM TEST	NO

Appendix B - Communications

Communications Interface

CAT3-DC-MIL is equipped with a serial communication interface RS232 to allow changing flow sensor calibration parameters (k-factors). The calibration parameters must be updated whenever the flow sensor is re-calibrated. The serial port may be accessed by removing the two screws from the top plate of the blue enclosure. External power must be supplied to the CAT3-DC-MIL in order to communicate.

Communications with the CAT3-DC-MIL also requires the use of the HOFFER HIT2A-301 Communications Cable and the Hoffer Windows Device Configuration Software. The computer serial port must be set to the following:

Baud rate:	2400
Data bits:	8
Parity:	none
Stop bits:	1
Handshaking:	None

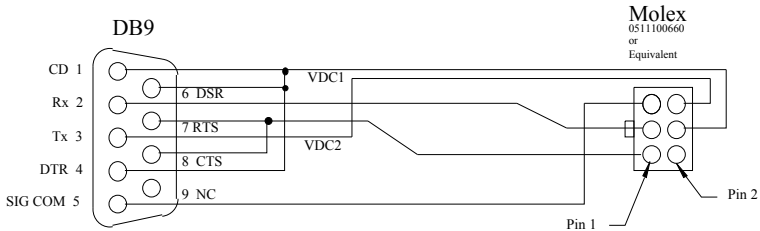

HIT2A-301 Communications Cable

Appendix C – Drawing

