

ACC-34

(MILITARY)

*MAG COIL FLOW RATE CONDITIONER
FREQUENCY TO ANALOG VOLTAGE*

USER'S MANUAL

HP- 245-MIL
September 2010

HOFFER
Flow Controls

Perfecting Measurement™

107 Kitty Hawk Lane • P.O. Box 2145 • Elizabeth City, NC 27909
1-800-628-4584 • (252) 331-1997 • Fax (252) 331-2886
www.hofferflow.com email: info@hofferflow.com

Notice

HOFFER FLOW CONTROLS, INC. MAKES NO WARRANTY OF ANY KIND WITH REGARD TO THIS MATERIAL, INCLUDING, BUT NOT LIMITED TO, THE IMPLIED WARRANTIES OF MERCHANTABILITY AND FITNESS FOR A PARTICULAR PURPOSE.

This manual has been provided as an aid in installing, connecting, calibrating, operating, and servicing this unit. Every precaution for accuracy has been taken in the preparation of this manual; however, HOFFER FLOW CONTROLS, INC. neither assumes responsibility for any omissions or errors that may appear nor assumes liability for any damages that may result from the use of the products in accordance with information contained in the manual.

HOFFER FLOW CONTROLS' policy is to provide a user manual for each item supplied. Therefore, all applicable user manuals should be examined before attempting to install or otherwise connect a number of related subsystems.

During installation, care must be taken to select the correct interconnecting wiring drawing. The choice of an incorrect connection drawing may result in damage to the system and/or one of the components.

Please review the complete model number of each item to be connected and locate the appropriate manual(s) and/or drawing(s). Identify all model numbers exactly before making any connections. A number of options and accessories may be added to the main instrument, which are not shown on the basic user wiring. Consult the appropriate option or accessory user manual before connecting it to the system. In many cases, a system wiring drawing is available and may be requested from HOFFER FLOW CONTROLS.

This document contains proprietary information, which is protected by copyright. All rights are reserved. No part of this document may be photocopied, reproduced, or translated to another language without the prior written consent of HOFFER FLOW CONTROLS, INC.

HOFFER FLOW CONTROLS' policy is to make running changes, not model changes, whenever an improvement is possible. This affords our customers the latest in technology and engineering. The information contained in this document is subject to change without notice.

RETURN REQUESTS / INQUIRIES

Direct all warranty and repair requests/inquiries to the Hoffer Flow Controls Customer Service Department, telephone number (252) 331-1997 or 1-800-628-4584. BEFORE RETURNING ANY PRODUCT(S) TO HOFFER FLOW CONTROLS, PURCHASER MUST OBTAIN A RETURNED MATERIAL AUTHORIZATION (RMA) NUMBER FROM HOFFER FLOW CONTROLS' CUSTOMER SERVICE DEPARTMENT (IN ORDER TO AVOID PROCESSING DELAYS). The assigned RMA number should then be marked on the outside of the return package and on any correspondence.

FOR **WARRANTY** RETURNS, please have the following information available BEFORE contacting HOFFER FLOW CONTROLS:

1. P.O. number under which the product was PURCHASED,
2. Model and serial number of the product under warranty, and
3. Repair instructions and/or specific problems relative to the product.

FOR **NON-WARRANTY** REPAIRS OR **CALIBRATIONS**, consult HOFFER FLOW CONTROLS for current repair/calibration charges. Have the following information available BEFORE contacting HOFFER FLOW CONTROLS:

1. P.O. number to cover the COST of the repair/calibration,
2. Model and serial number of the product, and
3. Repair instructions and/or specific problems relative to the product.

LIMITED WARRANTY

HOFFER FLOW CONTROLS, INC. ("HFC") warrants HFC's products ("goods") described in the specifications incorporated in this manual to be free from defects in material and workmanship under normal use and service, but only if such goods have been properly selected for the service intended, properly installed and properly operated and maintained. This warranty shall extend for a period of one (1) year from the date of delivery to the original purchaser (or eighteen (18) months if the delivery to the original purchaser occurred outside the continental United States). This warranty is extended only to the original purchaser ("Purchaser"). *Purchaser's sole and exclusive remedy is the repair and/or replacement of nonconforming goods as provided in the following paragraphs.*

In the event Purchaser believes the goods are defective, the goods must be returned to HFC, transportation prepaid by Purchaser, within twelve (12) months after delivery of goods (or eighteen (18) months for goods delivered outside the continental United States) for inspection by HFC. If HFC's inspection determines that the workmanship or materials are defective, the goods will be either repaired or replaced, at HFC's sole determination, free of additional charge, and the goods will be returned, transportation paid by HFC, using the lowest cost transportation available.

Prior to returning the goods to HFC, Purchaser must obtain a Returned Material Authorization (RMA) Number from HFC's Customer Service Department within 30 days after discovery of a purported breach of warranty, but no later than the warranty period; otherwise, such claims shall be deemed waived. See the Return Requests/Inquiries Section of this manual.

If HFC's inspection reveals the goods are free of defects in material and workmanship or such inspection reveals the goods were improperly used, improperly installed, and/or improperly selected for service intended, HFC will notify the purchaser in writing and will deliver the goods back to Purchaser upon (i) receipt of Purchaser's written instructions and (ii) the cost of transportation. If Purchaser does not respond within thirty (30) days after notice from HFC, the goods will be disposed of in HFC's discretion.

HFC does not warrant these goods to meet the requirements of any safety code of any state, municipality, or other jurisdiction, and Purchaser assumes all risk and liability whatsoever resulting from the use thereof, whether used singly or in combination with other machines or apparatus.

This warranty shall not apply to any HFC goods or parts thereof, which have been repaired outside HFC's factory or altered in any way, or have been subject to misuse, negligence, or accident, or have not been operated in accordance with HFC's printed instructions or have been operated under conditions more severe than, or otherwise exceeding, those set forth in the specifications for such goods.

THIS WARRANTY IS EXPRESSLY IN LIEU OF ALL OTHER WARRANTIES, EXPRESSED OR IMPLIED, INCLUDING ANY IMPLIED WARRANTY OF MERCHANTABILITY OR FITNESS FOR A PARTICULAR PURPOSE. HFC SHALL NOT BE LIABLE FOR ANY LOSS OR DAMAGE RESULTING, DIRECTLY OR INDIRECTLY, FROM THE USE OR LOSS OF USE OF THE GOODS. WITHOUT LIMITING THE GENERALITY OF THE FOREGOING, THIS EXCLUSION FROM LIABILITY EMBRACES THE PURCHASER'S EXPENSES FOR DOWNTIME OR FOR MAKING UP DOWNTIME, DAMAGES FOR WHICH THE PURCHASER MAY BE LIABLE TO OTHER PERSONS, DAMAGES TO PROPERTY, AND INJURY TO OR DEATH OF ANY PERSONS. HFC NEITHER ASSUMES NOR AUTHORIZES ANY PERSON TO ASSUME FOR IT ANY OTHER LIABILITY IN CONNECTION WITH THE SALE OR USE OF HFC'S GOODS, AND THERE ARE NO ORAL AGREEMENTS OR WARRANTIES COLLATERAL TO OR AFFECTING THE AGREEMENT. *PURCHASER'S SOLE AND EXCLUSIVE REMEDY IS THE REPAIR AND/OR REPLACEMENT OF NONCONFORMING GOODS AS PROVIDED IN THE PROCEEDING PARAGRAPHS. HFC SHALL NOT BE LIABLE FOR ANY OTHER DAMAGES WHATSOEVER INCLUDING INDIRECT, INCIDENTAL, OR CONSEQUENTIAL DAMAGES.*

Disclaimer

Specifications are subject to change without notice.
Some pages are left intentionally blank.

TABLE OF CONTENTS

SECTION I	PAGE
INTRODUCTION AND SPECIFICATIONS	1.1
SECTION II	
INSTALLATION	2.1
SECTION III	
CALIBRATION	3.1
SECTION IV	
OPERATION	4.1
SECTION V	
MAINTENANCE AND MAIN SCHEMATIC	5.1

SECTION I

ACC-34 MAGNETIC PICKOFF CONDITIONER/CURRENT CONVERTER

The Model ACC-34 is a signal converter subsystem that provides an analog current output signal that is directly proportional to flow rate. Several options are available to suit user requirements. An auxiliary pulse output is also provided. These features combine to form an interface between a flow transducer and a host system.

The input signal conditioning circuitry is designed to accept the low level flowmeter signal while providing rejection of unwanted noise and spurious signal. A signal threshold control is provided which allows the user to set the input sensitivity above the ambient noise level, thereby eliminating any false signal on the output.

Several output pulse configurations are provided which offer flexibility in the interface required by the host system. The output is available in the form of CMOS/TTL compatible pulse or in the form of an open collector.

SPECIFICATIONS

INPUT

Input protected, RF and band pass filtered, adjustable trigger level.
Input Impedance - 40 Kilo ohm (nominal).
Trigger Sensitivity - 10 millivolt RMS (minimum) 10 Hz to 1000 Hz.
Over Voltage - 120 volts RMS absolute (maximum).
Compatible with magnetic pickoffs.

ANALOG OUTPUT

Range 4 to 20 mA.
Controls - Non-interacting zero and span adjustments.
Accuracy $\pm 0.1\%$ F. S. 200 ppm/ $^{\circ}$ C.
Maximum Impedance - 325 ohms.
F. S. Frequency Range 75 Hz to 2500 Hz
(DIP SWITCH SELECTABLE).

PULSE SCALING CAPABILITY

(OPTIONAL) $\div 2, \div 4, \div 8, \div 16, \div 32, \div 64, \div 128$.and $\div 256$

PULSE OUTPUT**TTL/CMOS COMPATIBLE OPTION**

LOGIC 1 2.4V at -.800mA.

LOGIC 0 0.4V maximum at 100mA.

OPEN COLLECTOR OPTION

TYPE VMOS 2N6660

V Max. (Abs.) 60 VDC.

I Max. (Abs.) 100 mA.

AC OPTION

5Vp p Square Wave.

**POWER REQUIREMENTS
(OPTIONAL)**

115 VAC 50/60 Hz.

15-35 VDC.

TEMPERATURE

0° to 70°C Standard.

ENCLOSURE OPTIONS

Standard enclosure Style-2 Case (See outline drawing).

Explosion-Proof Enclosure.

Explosion-Proof Enclosure with 'O' ring seal.

NEMA-4 Enclosure.

CONTROLS AND ADJUSTMENTS**FUSE**

A circuit protection device located inside of case.

SENSITIVITY

A multiple turn control used to set the threshold sensitivity level above the ambient noise pickup.

RANGE

A dual in-line (DIP) switch located on the PCA-61 board, which is used to program the module to accept an input frequency range.

SPAN

A multiple turn adjustment which is used to set the voltage output signal to the desired span corresponding to the equivalent flow range (i.e., 4 to 20mA corresponding to 0-100 GPM).

ZERO

A multiple turn adjustment which is used to set output signal with no flow to the desired 'zero' value (i.e., 4mA).

SCALING FACTOR

A dual in-line (DIP) switch located on the PCA-60 board which is used to set the pulse scaling device factor to ÷2, ÷4, ÷8, ÷16, ÷32, ÷64, ÷128 and 256.

ORDERING INFORMATION

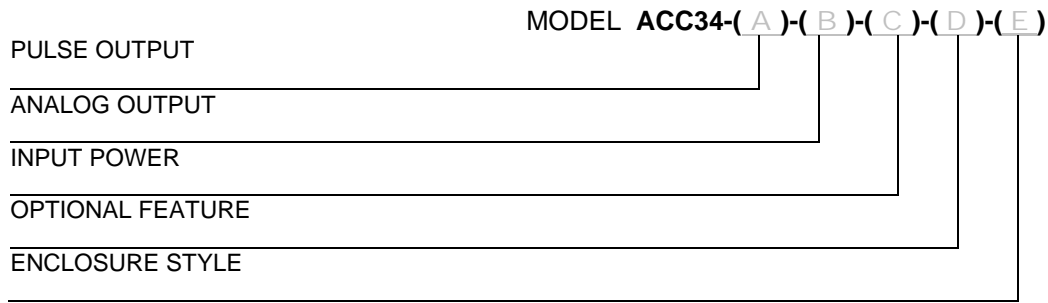

PULSE OUTPUT

MODEL ACC34-(A)-()-()-()-()

OPTION (A)

- (1) OPEN COLLECTOR
- (2) TTL/CMOS
- (3) AC SQUARE WAVE
- (5) 0-10 V SQUARE WAVE

ANALOG OUTPUT

MODEL ACC34-()-(B)-()-()-()

OPTION (B)

- (X) NONE
- (C) 4-20 MA
- (C1) 4-20 MA (ISOLATED)

INPUT POWER

MODEL ACC34-()-()-(C)-()-()

OPTION (C)

- (A) 115 VAC 50/60 HZ
- (B) 220 VAC 50/60 HZ
- (D) 15-35 VDC

OPTIONAL FEATURE

MODEL ACC34-()-()-()-(D)-()

OPTION (D)

- (PS) DIP SWITCH SELECTABLE
DIVIDE BY 2,4,8,16,32,64,128

ENCLOSURE STYLE

MODEL ACC34-()-()-()-()-(E)

OPTION (E)

- (2) STYLE 2 CASE, GENERAL PURPOSE
- (4/O) STYLE 4 CASE, EXPLOSION-PROOF WITH WATER TIGHT 'O' RING
MEETS CLASS I, GROUP C, D (ADALET CASE, XJS WITH FLAT COVER)
STOCK #200-0698
CLASS II, GROUPS E, F & G
CLASS III

NOTE: INSERT (X) IN MODEL NUMBER FOR EVERY OPTION NOT SPECIFIED.

**SIGNAL CONDITIONER/MAGNETIC COIL
APPROXIMATE WEIGHT = 3 LBS**

MODEL NUMBER ACC34-3-C1-A-X-5-MIL

FEATURES INCLUDE:

- AC SQUARE WAVE PULSE OUTPUT
- 4-20 MA (ISOLATED) ANALOG OUTPUT
- 115 VAC INPUT POWER REQUIRED
- STYLE 5, NEMA 4 (WALL MOUNT)
- MATING CONNECTORS:
 - S3106F-10SL-3S SIGNAL INPUT
 - S3106F-10SL-3P SIGNAL OUTPUT
 - S3106F-12S-3P ANALOG OUTPUT
 - S3106F-16-10S-POWER INPUT

NOTE: OPTION (5MSE) ENCLOSURE STYLE IS OBSOLETE - ANY RETURNED FOR REPAIR NEED TO BE UPGRADED.

SECTION II

FLOWMETER INSTALLATION

GENERAL

Proper application of the turbine flowmeter requires a suitable piping installation in order to achieve accurate and reliable operation.

The piping configuration immediately preceding and following the flowmeter is termed the meter run. Refer to the manufacturer's outline and installation instructions when installing the flowmeter and meter run.

RELATIVE: The performance of the turbine flowmeter is affected by the fluid swirl and non-uniform velocity profiles. The following recommendation will reduce such flow irregularities:

It is advisable not to locate the meter run immediately downstream of pumps, partially opened valves, bends or other similar piping configurations. In addition, the area surrounding the flowmeter should be free of sources of electrical noise such as motors, solenoids, transformers and power lines which may be coupled to the pickoff device.

The metering section should not be subjected to excessive vibration or shock. Such a condition may result in a mechanically induced output signal from the pickoff device.

METER RUN: In general, the meter run should be chosen to have the same inner diameter as the meter bore. A minimum of 10 pipe diameters of straight pipe upstream and 5 pipe diameters downstream are required. Where this optimum line configuration can not be implemented, it is advisable to install a flow straightener properly positioned upstream of the flowmeter. Orientation is not a critical factor, however, horizontal is preferred orientation.

BYPASS RUN: A properly sized bypass run with suitable blocking valves may be equipped where an interruption in fluid flow for turbine meters servicing cannot be tolerated.

STRAINER: A strainer, filter and/or air eliminator is recommended to reduce the potential of fouling or damage. See table for recommended mesh size.

On initial startup of a line, it is advisable to install a spool piece purging the line to eliminate damaging the flowmeter, due to flux, tape, solder, welds or other contaminants carried along by the fluid stream.

CAVITATION: Cavitation causes measurement inaccuracies in turbine flowmeters and should be avoided by suitable line and operating configurations.

Whenever the pressure within a pipeline instantaneously falls below the equilibrium vapor pressure of the fluid, a portion of the fluid vaporizes and forms bubbles in the pipeline. This is termed cavitation. Cavitation is eliminated by maintaining adequate back pressure on the flowmeter. A downstream valve that provides the necessary back pressure is one means for preventing cavitation in the metering run. Control valves should be located downstream, if possible. Some installations may also make use of a vapor eliminator upstream of the flowmeter.

The minimum required back pressure may be estimated using the following equation:

$$\text{Min. Back Pressure} = 1.25 \times \text{Vapor Pressure} + 2 \times \text{Pressure Drop}$$

INSTALLATION WIRING LAYOUT FOR INTERCONNECTIONS USING MCP PICKUP

In considering the interconnections between the flowmeter and the flow measurement system some attention must be given to anticipated noise sources and to the coupling of these noise sources to the interconnecting wiring.

Noise signals may be coupled inductively or capacitively into the wiring between the flowmeter and the electronic measuring systems. In general, utilizing a shielded, twisted pair for the interconnection greatly reduces this coupling. The shield should be grounded on one end of the cable only. In general, grounding only on the electronic measuring system is best.

However, even with proper interconnecting cabling Crosstalk with other signal lines or power lines may still occur and should be avoided. Physical isolation in the manner in which the wiring is run reduces the chance of potential problems.

It is common to transmit the low level output signal from the flowmeter several hundred feet through a shielded, twisted pair instrument cable. Where a noisy environment is suspect, it is recommended that a preamplifier be installed on or near the flowmeter to the electronic measuring system. Suitable accessory models are available from manufacturer.

INSTALLATION ACC-34 (AC POWERED VERSION)

The Model ACC-34 should be placed in a convenient location, which maintains access to the unit should repairs or readjustment be required.

Refer to outline and installation drawing for the appropriate case type to be installed. Drill appropriate mounting holes as required.

Refer to wiring installation drawing for appropriate terminals for interconnections. Connections to the terminal block should be carefully dressed to avoid having bare wires extend past the screw clamp on the terminal block. This is particularly important for units mounted within the explosion-proof enclosure. Wires should be neatly dressed near the bottom of the enclosure to assure wiring will not become fouled when the cover is installed.

Connect two conductor shielded cable from the flowmeter. Connect shield to ACC-34 only.

Line power connection should be made through a circuit breaker so that power can be turned off while servicing accessory model. Power is 117V AC +/- 10%, an earth ground connection is also required.

Connect pulse output if used, several output pulse waveforms are available factory equipped. Wire to appropriate terminal for waveform desired and specified.

If the analog output has been equipped, connect wiring to appropriate terminals and load. A shielded, twisted pair wire is recommended. Ground shield on one end only. Use some precautions as described for flowmeter input signal.

NOTES:

1. FACTORY RECOMMENDS 10" PIPE DIA. UPSTREAM AND 5 PIPE DIA. DOWNSTREAM OF SAME SIZE PIPE AS FLOWMETER. A FLOW STRAIGHTENER IS RECOMMENDED IF THIS IS NOT POSSIBLE OR FOR CUSTODY TRANSFER APPLICATIONS.

REVISIONS

REV	DESCRIPTION	DATE	APP
A	REDRAWN	1-31-92	
B	ADDED NOTE 2, CHG'D MESH SIZE	3-17-92	
C	DRAWING NO. WAS INSTL-104.	950907	<i>JL</i>

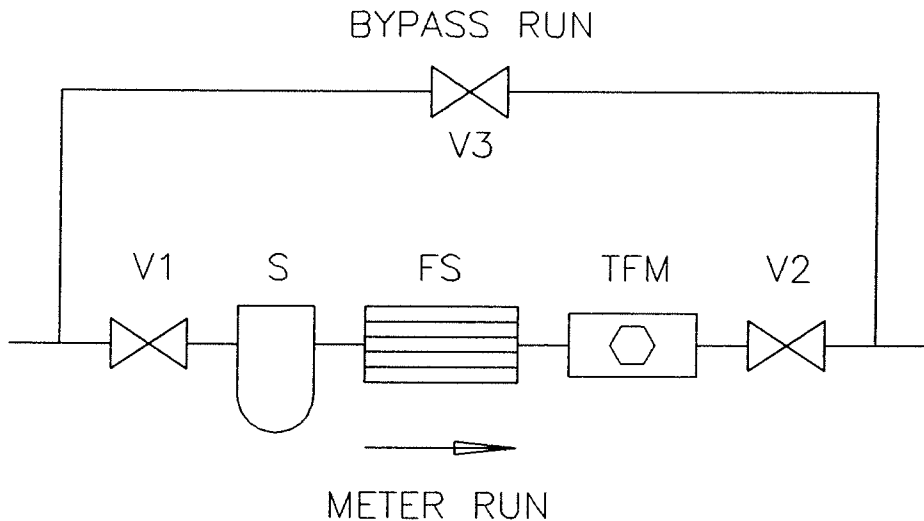

METER SIZE	MESH SIZE
MF SERIES	100
1/4" - 1/2"	100
5/8" - 1 1/4"	70
1 1/2" - 3"	40
4" - 12"	24

- V1, V2 BLOCKING VALVE
- S STRAINER
- FS FLOW STRAIGHTENER
- TFM TURBINE FLOWMETER
- V3 BYPASS VALVE

REPLACES INSTL-104

		MATERIAL	DRAWN DW	DATE 1-31-92	H HOFFER FLOW CONTROLS, INC. ELIZABETH CITY, NC 27909
			CHECK JD	1-31-92	
			QA H. COVELL	1-31-92	
		FINISH	PROJ ENG KRH	1-31-92	
					TITLE TYPICAL TURBINE INSTALLATION
		CONFIDENTIAL PROPERTY OF HOFFER FLOW CONTROLS, INC. (HFC) NOT TO BE DISCLOSED TO OTHERS, REPRODUCED, OR USED FOR ANY OTHER PURPOSE, EXCEPT AS AUTHORIZED IN WRITING BY HFC. MUST BE RETURNED ON DEMAND, ON COMPLETION OF ORDER OR OTHER PURPOSE FOR WHICH LENT.	UNLESS OTHERWISE SPECIFIED DIMENSIONS ARE IN INCHES TOLERANCES OTHER THAN RAW MATERIAL SHALL BE HELD AS FOLLOWS:		
			2 PLACE DECIMAL ±.01		SIZE A
			3 PLACE DECIMAL ±.005		CAGE CODE 33321
			FRACTIONAL ±1/64		DWG NO 500-0194
			ANGULAR ±1/2°		REV C
NEXT ASSY	USED ON				SCALE NONE
APPLICATION					SHEET 1 OF 1

NOTES:

1. WIRE TO 7 OR 8 DEPENDING ON TYPE OF OUTPUT WAVEFORM DESIRED AND SPECIFIED.
2. POWER INPUT 115VAC OR 230VAC, BASED ON FACTORY OPTION. SEE MODEL NUMBER FOR CORRECT VOLTAGE.

REVISIONS

REV	DESCRIPTION	DATE	APP
A	NOTE 2. (RG)	1/89	RG
B	REDRAWN ON CAD. (CS)	930323	JD
C	DWG NO WAS ACC34-701 (CS)	951121	JD
D	DWG NO WAS 700-0122	000621	ES

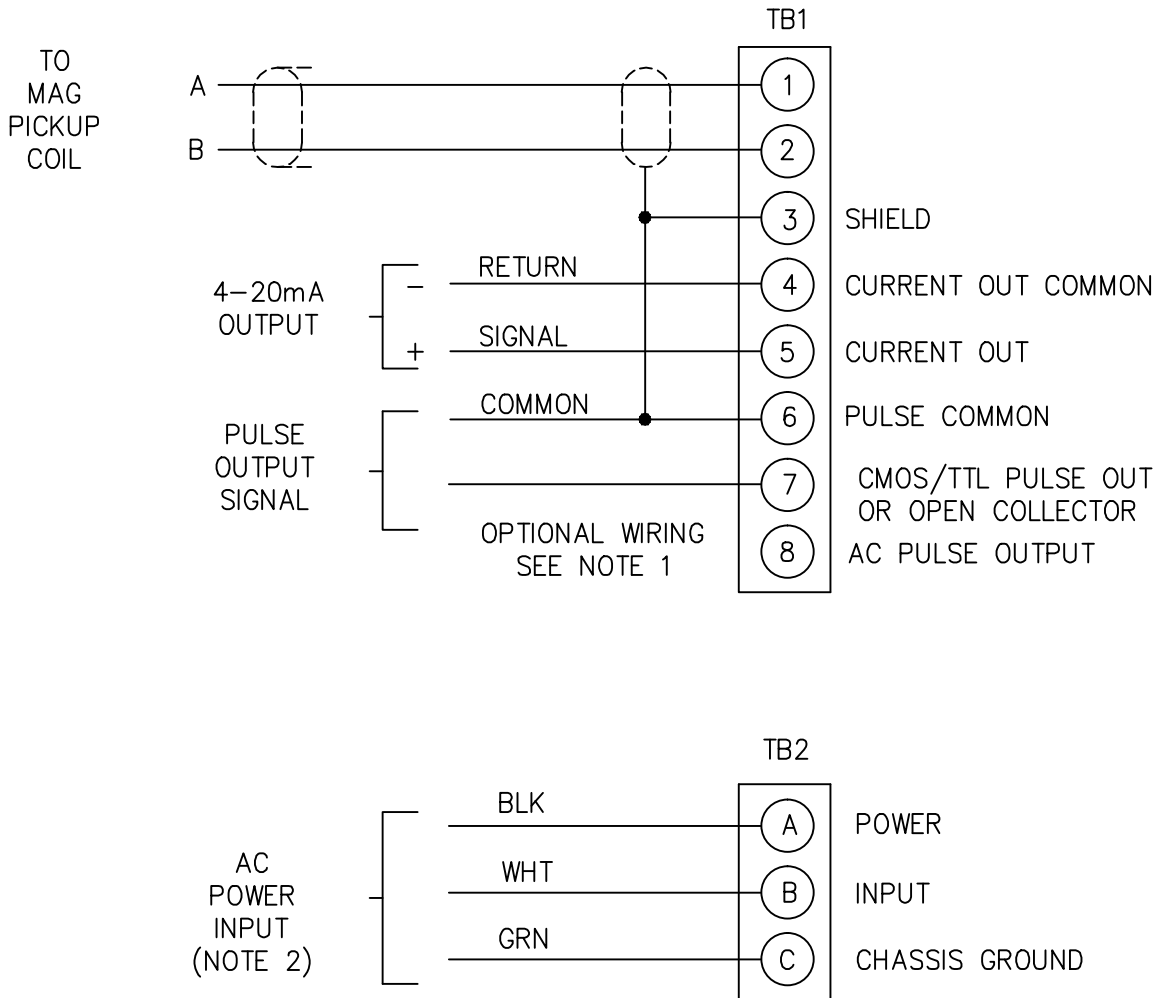

REPLACES 700-0122

		MATERIAL	CONTRACT/JN		 HOFFER FLOW CONTROLS, INC. ELIZABETH CITY, NC 27909	
			DRAWN	DATE		
			RG	11/82		
			CHECK	11/82		
		FINISH	QA		TITLE INSTALLATION WIRING- ACC34 (AC)	
			PROJ ENG			
		CONFIDENTIAL PROPERTY OF HOFFER FLOW CONTROLS, INC. (HFC) NOT TO BE DISCLOSED TO OTHERS, REPRODUCED, OR USED FOR ANY OTHER PURPOSE, EXCEPT AS AUTHORIZED IN WRITING BY HFC. MUST BE RETURNED ON DEMAND, ON COMPLETION OF ORDER OR OTHER PURPOSE FOR WHICH LENT.	UNLESS OTHERWISE SPECIFIED DIMENSIONS ARE IN INCHES TOLERANCES OTHER THAN RAW MATERIAL SHALL BE HELD AS FOLLOWS:		SIZE A	
NEXT ASSY	USED ON		2 PLACE DECIMAL ±.01 3 PLACE DECIMAL ±.005 FRACTIONAL ±1/64 ANGULAR ±1/2°	CAGE CODE	DWG NO	REV
APPLICATION				A 33321	ACC34-701	D
			SCALE	SHEET 1 OF 1		
			NONE			

NOTES:

1. UNIT MAY BE INSTALLED IN EXPLOSION PROOF ENCLOSURE.

REVISIONS

REV	DESCRIPTION	DATE	APP
A	REVISED AND REDRAWN. (CS)	920921	JD
B	DRAWING NO. WAS ACCXX-401.	950830	jo

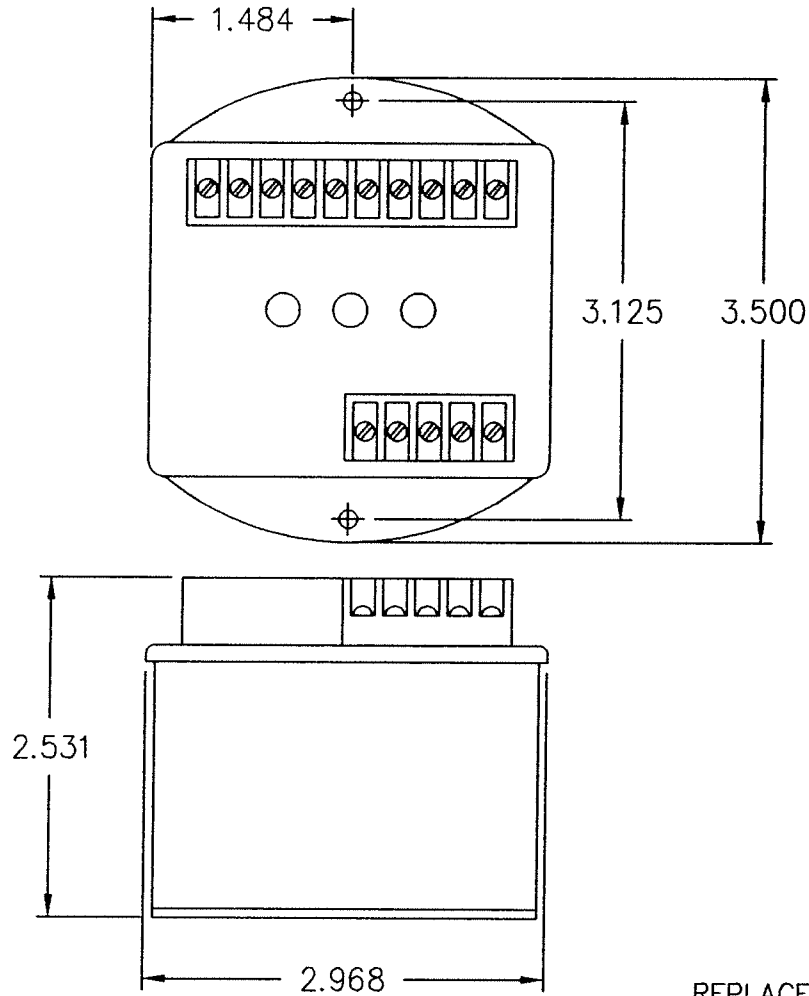

REPLACES ACCXX-401

		MATERIAL	CONTRACT/JN		 H OFFER FLOW CONTROLS, INC. ELIZABETH CITY, NC 27909	
			DRAWN	DATE		
			J.F.	9/82		
			CHECK			
		FINISH	R.S.	11/82	TITLE	
			QA		CASE OUTLINE, ACC STYLE-2 CASE	
			PROJ ENG			
		CONFIDENTIAL PROPERTY OF HOFFER FLOW CONTROLS, INC. (HFC) NOT TO BE DISCLOSED TO OTHERS, REPRODUCED, OR USED FOR ANY OTHER PURPOSE, EXCEPT AS AUTHORIZED IN WRITING BY HFC. MUST BE RETURNED ON DEMAND, ON COMPLETION OF ORDER OR OTHER PURPOSE FOR WHICH LENT.	UNLESS OTHERWISE SPECIFIED DIMENSIONS ARE IN INCHES TOLERANCES OTHER THAN RAW MATERIAL SHALL BE HELD AS FOLLOWS: 2 PLACE DECIMAL ±.01 3 PLACE DECIMAL ±.005 FRACTIONAL ±1/64 ANGULAR ±1/2°		SIZE	
NEXT ASSY	USED ON				FSCM NO	DWG NO
APPLICATION				A 33321	500-0173	B
				SCALE	SHEET 1 OF 1	
				NONE		

DWG NO.	ACC34-904	SH	1	REV	A
REVISIONS					
ZONE	REV	DESCRIPTION	DATE	APP	
	A	WIRING DIAGRAM; SIGNAL OUT BLUE WIRE WAS WHT/BRN	100902	JJ	

DATE	01/06/29
CHECK	J.KREBS
PROJ ENG	KRH

TITLE	
HOFFER FLOW CONTROLS, INC ELIZABETH CITY, NC 27909	
ASSEMBLY DRAWING, MODEL	
ACC34-3-C1-A-X-5-MIL	
SIZE	C
CASE CODE	33321
DWG NO	ACC34-904
SCALE	NONE
SHEET	1 OF 1

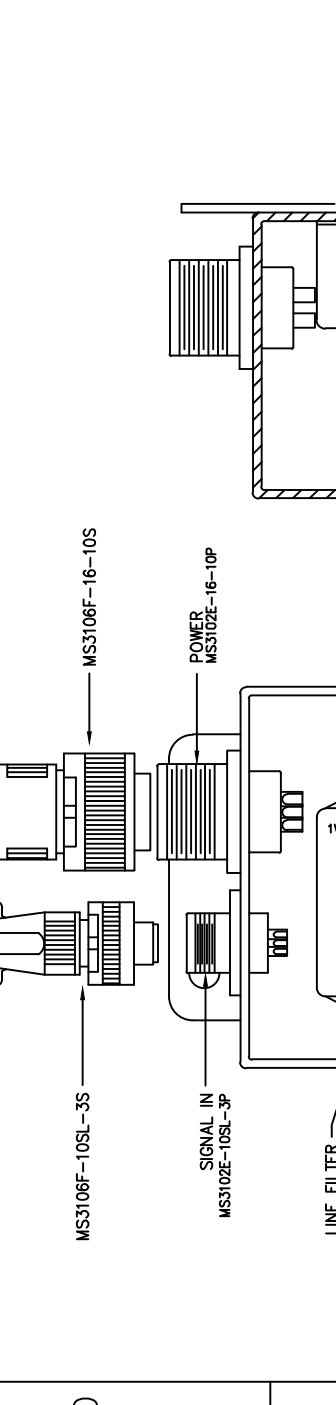
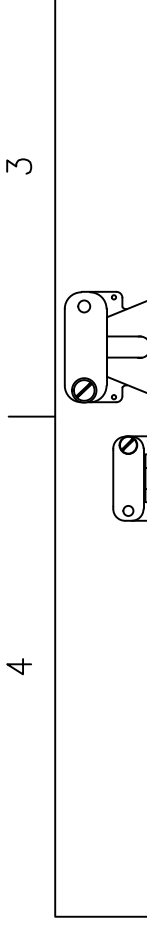

MATERIAL	
FINISH	
CONFIDENTIAL PROPERTY OF HOFFER FLOW CONTROLS, INC. (HFC) NOT TO BE DISCLOSED TO OTHERS, REPRODUCED, OR USED FOR ANY OTHER PURPOSE, EXCEPT AS AUTHORIZED IN WRITING BY HFC. MUST BE RETURNED ON OTHER PURPOSE FOR WHICH LENT.	
UNLESS OTHERWISE SPECIFIED DIMENSIONS ARE IN INCHES. TOLERANCES OTHER THAN THE SIZE OF RAW MATERIAL SHALL BE HELD AS FOLLOWS:	
1 PLACE DECIMALS	± .01
2 PLACE DECIMALS	± .005
3 PLACE DECIMALS	± .0025
FRACTIONAL ANGULAR	± 1/2°

DATE	01/06/29
CHECK	J.KREBS
PROJ ENG	KRH
TITLE	
HOFFER FLOW CONTROLS, INC ELIZABETH CITY, NC 27909	
ASSEMBLY DRAWING, MODEL	
ACC34-3-C1-A-X-5-MIL	
SIZE	C
CASE CODE	33321
DWG NO	ACC34-904
SCALE	NONE
SHEET	1 OF 1

SECTION III

CALIBRATION OF ANALOG OUTPUT - GENERAL CONSIDERATIONS

INTRODUCTION

In general, all flow measurement systems by Hoffer Flow Controls have been factory calibrated as specified by the user, at the time of purchase, free of charge.

All systems which underwent such a factory calibration have a calibration card attached prior to shipment. This card contains the details of analog outputs, as well as, other useful calibration data.

Field calibration is only required when a change has occurred or is sought to the measuring system. Such a change may be due to repair, replacement or recalibration of the flowmeter, or perhaps a change in the analog output span.

PROCEDURE

Begin by determining the equivalent maximum volumetric flow rate in GPM, expected by the application, term this GPM(MAX). GPM(MAX) may be calculated based on the analog output scale requirements or may be the maximum flow rate listed on the flowmeter's calibration sheet.

From the calibration constant (or K-Factor) listed on the data sheet for the flowmeter, obtain the frequency corresponding to GPM(MAX) using Equation-1 and designate this frequency F(MAX).

Equation-1:

$$F_{MAX} = \frac{K_{AVG} \times GPM_{MAX}}{60}$$

The analog output of the ACC-34 may be calibrated with the aid of an external oscillator used in conjunction with a frequency counter.

The external oscillator is used to supply a test frequency. In this method, the external oscillator is connected to the signal input terminals as shown in Figure-1. The oscillator's output frequency is set to equal F(MAX) as indicated on the frequency counter.

1. The course range adjustment is accomplished by selecting a switch position on a DIP switch located on the PCA-61 printed circuit card. See Table A to determine required switch position and set into switch as shown on drawing ACC-34-403 for anticipated F(MAX).

NOTE: Input power should be removed during this step. It is necessary to open the cover of the enclosure by removing two screws and lifting the cover. Refer to drawing ACC34B-403.

2. Connect a digital milliampmeter or equivalent, across the current output terminals.
3. Adjust ZERO control for desired zero current (i.e. 4mA).
4. Turn SPAN POT fully CCW until detent is felt or 25 turns.
5. Inject the test frequency equal to F_{MAX} while adjusting "SPAN" for current equal to 20mA \pm 20mA. See test setup shown in Figure-1.
6. Iterate steps 4 and 5 until no change is observed.

FOR PULSE SCALING OPTION

1. An optional DIP switch is located on the PCA-60 printed circuit card. See Table B to determine required switch position and set into switch, as shown in drawing ACC34-403, for required divided by N.
2. For a required divide by 64, 128 or 256, switch position 6 must be jumpered as shown on drawing ACC34-403.

TABLE A

F(MAX)	RANGE SELECT SWITCH POSITION
75 to 150	1
150 to 300	2
300 to 600	3
600 to 1200	4
1200 to 2400	5

TABLE B

$\div N$	SWITCH POSITION
2	1
4	2
8	3
16	4
32	5
64*	6
128*	
256*	

*NOTE: For divide by 64, 128 or 256, switch position 6 is jumpered to appropriate location of PCA-60 printed circuit board.

NOTES:

1. USE TEST AMPLITUDE OF 100mVRMS OR LESS, SINUSOIDAL WAVE FORM.
2. REMOVE ALL OTHER INTERCONNECTIONS OTHER THAN THOSE SHOWN.
3. OBSERVE CAUTION WHEN PERFORMING CALIBRATION.

REVISIONS			
REV	DESCRIPTION	DATE	APP
A	POWER DISTINGUISHED. (RG)	1/89	RG
B	REDRAWN ON CAD. (CS)	930323	JD
C	DWG NO WAS ACC34-602 (CS)	951121	JD
D	DWG NO WAS 700-0121	000621	ES

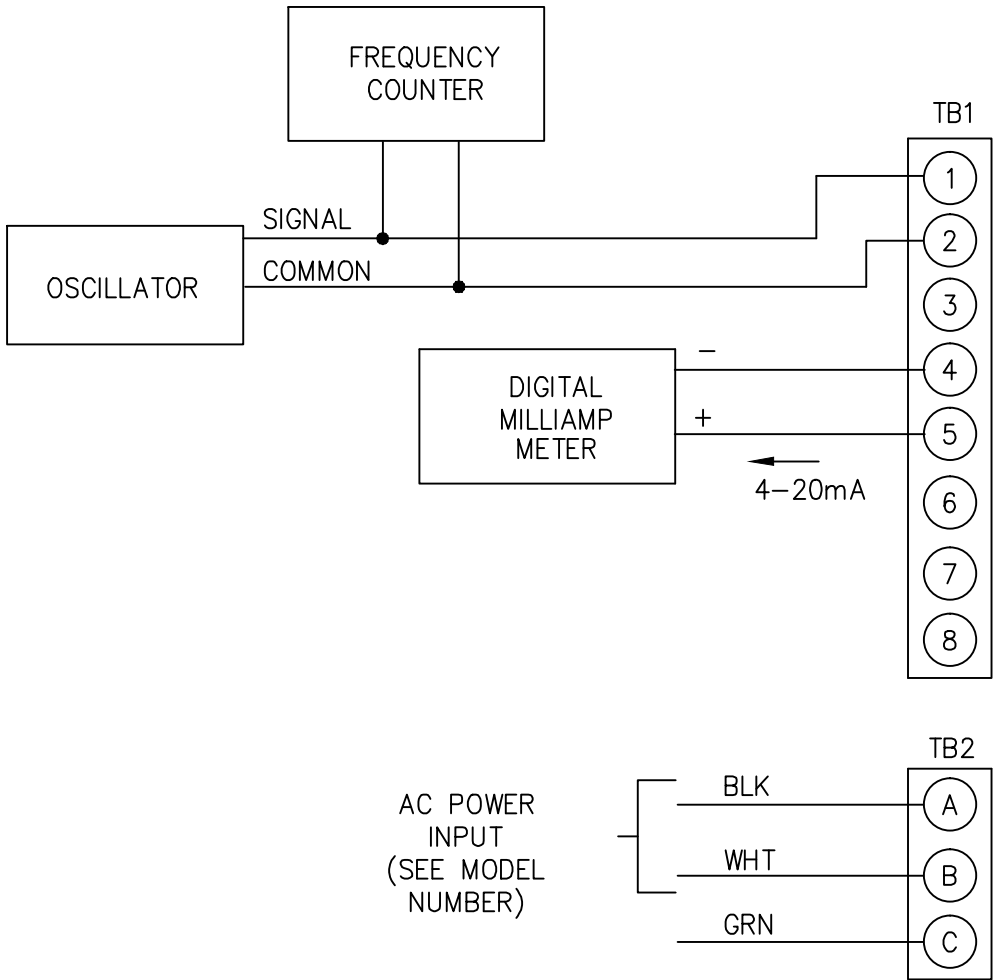

REPLACES 700-0121

		MATERIAL	CONTRACT/JN		 HOFFER FLOW CONTROLS, INC. ELIZABETH CITY, NC 27909	
			DRAWN	DATE		
			RG	2-18-83		
			CHECK			
			JD	2-18-83		
		FINISH	QA		TITLE	
			PROJ ENG		CALIBRATION	
			RG	2-18-83	SETUP-	
		CONFIDENTIAL PROPERTY OF HOFFER FLOW CONTROLS, INC. (HFC) NOT TO BE DISCLOSED TO OTHERS, REPRODUCED, OR USED FOR ANY OTHER PURPOSE, EXCEPT AS AUTHORIZED IN WRITING BY HFC. MUST BE RETURNED ON DEMAND, ON COMPLETION OF ORDER OR OTHER PURPOSE FOR WHICH LENT.	UNLESS OTHERWISE SPECIFIED DIMENSIONS ARE IN INCHES TOLERANCES OTHER THAN RAW MATERIAL SHALL BE HELD AS FOLLOWS:		FIGURE 1 (AC)	
NEXT ASSY	USED ON		2 PLACE DECIMAL	±.01	SIZE	CAGE CODE
			3 PLACE DECIMAL	±.005	A	33321
APPLICATION			FRACTIONAL	±1/64	DWG NO	
			ANGULAR	±1/2°	ACC34-602	
					REV	
					D	
				SCALE	NONE	
					SHEET 1 OF 1	

ZONE	REV	DESCRIPTION	DATE	APP
	A	ADDED NOTE 1.	2/84	
	B	P.S. OPT	6/85	JD
	C	REDRAWN ON CAD.	930324	JD
	D	DRAWING NO. WAS ACC34B-403.	950829	JD
	E	DRAWING NO. WAS 700-0017	000621	ES
	F	REVISED PER ECP 572. ADDED 'A' SCREWS, ADDED NOTE FOR MILITARY VERSION	100831	JJ

NOTES:

- FUSE AND TRANSFORMER ARE EQUIPPED FOR 110VAC POWER ONLY.
- TO REMOVE COVER (MILITARY VERSION ONLY)
 - TURN POWER TO ACC34 OFF.
 - REMOVE TWO MACHINE SCREWS FROM THE TOP COVER OF THE BLUE CASE
 - LIFT COVER BEING CAREFUL OF THE LID WIRING
 - RANGE SWITCH WILL BE VISIBLE ON THE CENTER, RIGHT SIDE OF THE CIRCUIT BOARD AND CAN BE SET AS NEEDED IN THE TABLE BELOW.
 - RE-ASSEMBLE THE LID BACK ONTO THE CASE AND ATTACH WITH SCREWS REMOVED IN STEP 2.
- TO REMOVE COVER/PRINTED CIRCUIT SUBASSEMBLY
 - TURN POWER TO ACC34 OFF.
 - REMOVE TWO MACHINE SCREWS FROM SIDES OF CASE
 - LIFT COVER/PRINTED CARD ASSEMBLY OUT.
- REPLACING FUSE
 - REMOVE COVER/PRINTED CIRCUIT SUBASSEMBLY
 - LOCATE FUSE ON SUBASSEMBLY
 - PULL FUSE FROM SOCKET USING FINGERS (PLIERS ARE NOT RECOMMENDED)
 - INSTALL NEW FUSE
 - REASSEMBLE INTO LOWER CASE
- RANGE SELECT / PULSE SCALING PROGRAM
 - REMOVE COVER/PRINTED CIRCUIT SUBASSEMBLY
 - TURN 'ON' DESIRED RANGE POSITION USING A BALL POINT PEN OR SIMILAR OBJECT. SEE RANGE SELECT/ PULSE SCALING DETAIL.
 - REASSEMBLE INTO LOWER CASE

RANGE SELECT / PULSE SCALING DETAIL

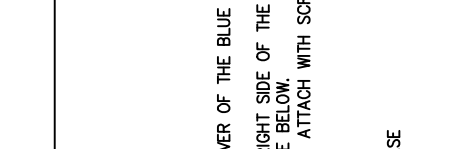

SWITCH 2 IS SHOWN DEPRESSED FOR ILLUSTRATION ONLY
NOTE: SELECT ONE SWITCH ONLY. ALL OTHER SWITCHES MUST BE OFF.

RANGE SELECT

SELECT SWITCH	F MAX
1	75-150
2	150-300
3	300-600
4	600-1200
5	1200-2400
6	NOT USED

PULSE SCALING

SELECT SWITCH	DIVIDE BY
1	2
2	4
3	8
4	16
5	32
6*	64,128, OR 256*

* DIVIDE BY 64, 128 OR 256 IS FACTORY WIRED CONSULT FACTORY IF CHANGE IS DESIRED.

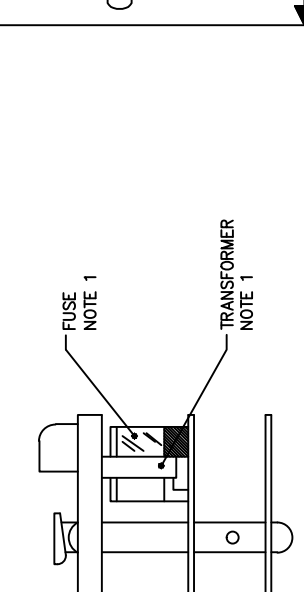

RANGE SELECT SWITCHES

PULSE SCALING SWITCHES

APPLICATION

USED ON

NEXT ASSY

UNLESS OTHERWISE SPECIFIED DIMENSIONS ARE IN INCHES. TOLERANCES OTHER THAN THE SIZE OF RAW MATERIAL SHALL BE HELD AS FOLLOWS:

1	PLACE DECIMALS ± .01
2	PLACE DECIMALS ± .005
3	PLACE DECIMALS ± .0025
4	FRACTIONAL ANGULAR ± 1/2°

CONFIDENTIAL PROPERTY OF HOFFER FLOW CONTROLS, INC. (HFC) NOT TO BE DISCLOSED TO OTHERS, REPRODUCED OR USED FOR ANY OTHER PURPOSE, EXCEPT AS AUTHORIZED IN WRITING BY HFC. MUST BE RETURNED OR DESTROYED FOR WHICH LEFT.

REPLACES 700-0017

H OFFER FLOW CONTROLS, INC.
ELIZABETH CITY, NC

TITLE

CONTROLS AND ADJUSTMENTS-ACC34

SIZE C

FSCM NO C 33321

DWG NO ACC34-403

REV F

SCALE N/A

SHEET 1 OF 1

1

2

3

4

1

2

3

4

1

2

3

4

1

2

3

4

1

SECTION IV

ACC34 FREQUENCY/CURRENT FLOW CONVERTER SUBSYSTEM

INITIAL STARTUP

Perform any purging of piping with spool piece in place. Once completed, install the flowmeter and connect cabling to pickup coil. If false counting action occurs turn sensitivity control clockwise.

OPERATION

The pulse output and analog output commence with flow through the flowmeter.

For the analog output, the span is then established by either the factory calibration or field calibration. The range is 4-20mA DC into a maximum of 325 ohms of loop resistance.

PRINCIPLE OF OPERATION

A simplified block diagram of the ACC34 Frequency/Current Flow Converter Subsystem is given on drawing ACC34-601. Key functional blocks, as well as, information flow are designated. The basic operation of the system is as follows:

The frequency signal from the flowmeter is connected to the ACC34 with a twisted pair shielded cable. The signal enters through the SENSITIVITY control which is used to reject unwanted noise by raising the trigger threshold above the background noise present.

The low level flowmeter signal is then passed through a special conditioning chain where it is amplified and shaped into a train of digital pulses whose frequency is related to the volume flow rate.

ANALOG OUTPUT

The signal entering the frequency to analog converter is passed through a combination of divide by N and DIP switch MATRIX. The QN output is chosen, whose pulse rate is between 75 and 150 Hz at the maximum flow rate to be measured. This scaled pulse rate is fed into a precision monostable circuit. The output of the monostable is then filtered into an analog voltage that is proportional to volumetric flow rate.

The output amplifier is a voltage to current amplifier. It offers zero and span available in a standard process range of 4-20mA.

SECTION V

MAINTENANCE, GENERAL

Hoffer Flow Controls Flow Measurement Systems are constructed to give a long service life in the targeted measuring field and service environment. However, problems do occur from time to time and the following points should be considered for preventive maintenance and repairs.

The bearing type used in the flowmeter chosen to give compromise between long life, chemical resistance, ease of maintenance and performance. A preventive maintenance schedule should be established to determine the amount of wear which has occurred since last overhaul. See user's manual for flowmeter for further instructions.

A spare parts list has been provided, which at the discretion of the user, may be user-stocked. Consult with the manufacturer if an abridged spare parts list is sought. The recommended spare parts list may be found following this section and in the user's manual for the flowmeter.

In case the flow measurement system malfunctions or becomes inoperative, a troubleshooting procedure is enclosed.

Factory consultation is available to assist in diagnosing problems. In addition, factory repair parts and service are available for individuals who wish to utilize this service.

A complete set of schematic diagrams for all printed cards are available from Hoffer Flow Controls for users who wish their own personnel to service the measuring system.

NOTE: - All printed circuit cards are warranted for one year after date of sale.
- All printed circuit cards may be factory repaired at a nominal fee for parts and labor after warrantee period.

TROUBLESHOOTING AND MAINTENANCE

INTRODUCTION

In case of an inoperable or malfunctioning system the following procedures can be used to isolate the faulty wiring, printed circuit boards and/or alternate causes. The majority of repairs can be made in the field thereby reducing the time a unit is out of service.

A recommended spare parts list is given immediately following the troubleshooting portion of this manual. The necessary documentation is contained within this manual with the exception of the calibration data sheet for the turbine flowmeter. This calibration is supplied separately.

Factory consultation is available to assist in diagnosing problems. Note that in some cases factory repairs can be provided.

Failure conditions are listed and the possible corrective actions given to eliminate the observed problem.

GENERAL INSPECTION TO DETERMINE IF UNIT IS OPERATING PROPERLY

Proper operation of the ACC34 can be assumed when with power applied to the unit:

1. The pulse output produces a pulse train of the desired amplitude when flow through the flow transducer occurs.
2. The analog output produces a current output signal of 4-20mA with a span corresponding to that established by the calibration procedure.

OBSERVED CONDITION

CORRECTIVE ACTION

- | | |
|--------------------------------|---|
| A. NO PULSE OUTPUT | <ol style="list-style-type: none">1. Inspect terminal strip wiring for conformity to the installation instructions and for acceptable workmanship.2. Verify correct fuse is good with an ohm meter. See dwg. ACC34-403.3. Determine if flowmeter rotor is fouled.4. Defective pickup coil. Replace.5. Defective cable. Replace.6. Defective ACC34. Repair or replace.7. Sensitivity potentiometer turned fully clockwise - unit will not function properly. |
| B. PULSING OUTPUT WITH NO FLOW | <ol style="list-style-type: none">1. Defective pickup coil. Replace.2. Defective cable. Replace.3. Defective ACC34. Repair or replace. |
| C. ANALOG OUTPUT MALFUNCTION | <ol style="list-style-type: none">1. Improper wiring terminations. Correct wiring.2. ACC34 improperly calibrated. Recalibrate.3. Defective circuitry within the ACC34. Factory repair ACC34. |

NOTE: Refer to flowmeter user's manual for repair instructions for the turbine flowmeter.

MODEL ACC34 FREQUENCY/CURRENT FLOW CONVERTER SUBSYSTEM

TABLE 1 - RECOMMENDED SPARE PARTS LIST

<u>PART NUMBER</u>	<u>DESCRIPTION</u>	<u>QTY.</u>
1/20 AMP	FUSE, POWER SUPPLY	1 BOX
ACC34-XX	CONDITIONER/CONVERTER	1
PC-XX-XX	COIL	1

NOTE: Additional spare parts may be recommended for the turbine flowmeter. See user's manual for turbine flowmeter for details.